

**AUTOMOBILE ENGINEERING**

Course	Code	Credits	L-T-P	Assessment		Exam duration
				SEE	CIA	
<b>Automobile</b>	15ME655	3	3-0-0	80	20	3 Hrs

**Course learning objectives:** The student will be able to learn

- The layout and arrangement of principal parts of an automobile.
- The working of transmission and brake systems.
- The operation and working of steering and suspension systems.
- To know the Injection system and its advancements.
- To know the automobile emissions and its effects on environment.

**MODULE 1**

**ENGINE COMPONENTS AND IT'S PRINCIPLE PARTS:** Spark Ignition (SI) & Compression Ignition (CI) engines, cylinder – arrangements and their relatives merits, Liners, Piston, connecting rod, crankshaft, valves, valve actuating mechanisms, valve and port timing diagrams, Types of combustion chambers for S.I.Engine and C.I.Engines, methods of a Swirl generation, choice of materials for different engine components, engine positioning. Concept of HCCI engines, hybrid engines, twin spark engine, electric car.

**COOLING AND LUBRICATION:** cooling requirements, types of cooling- thermo siphon system, forced circulation water cooling system, water pump, Radiator, thermostat valves. Significance of lubrication, splash and forced feed system. **10 Hours**

**MODULE 2**

**TRANSMISSION SYSTEMS:** Clutch-types and construction, gear boxes- manual and automatic, gear shift mechanisms, Over drive, transfer box, fluid flywheel, torque converter, propeller shaft, slip joints, universal joints ,Differential and rear axle, Hotchkiss Drive and Torque Tube Drive.

**BRAKES:** Types of brakes, mechanical compressed air, vacuum and hydraulic braking systems, construction and working of master and wheel cylinder, brake shoe arrangements, Disk brakes, drum brakes, Antilock –Braking systems, purpose and operation of antilock-braking system, ABS Hydraulic Unit, Rear-wheel antilock & Numerical. **08 Hours**

**MODULE 3**

**STEERING AND SUSPENSION SYSTEMS:** Steering geometry and types of steering gear box- Power Steering, Types of Front Axle, Suspension, Torsion bar suspension systems, leaf spring, coil spring, independent suspension for front wheel and rear wheel, Air suspension system.

**IGNITION SYSTEM:** Battery Ignition system, Magneto Ignition system, electronic Ignition system.

**08 Hours**

**MODULE 4**

**SUPERCHARGERS AND TURBOCHARGERS:** Naturally aspirated engines, Forced Induction, Types of superchargers, Turbocharger construction and operation, Intercooler, Turbocharger lag.

**FUELS, FUEL SUPPLY SYSTEMS FOR SI AND CI ENGINES:** Conventional fuels, alternative fuels, normal and abnormal combustion, cetane and octane numbers, Fuel mixture requirements for SI engines, types of carburetors, C.D.& C.C. carburetors, multi point and single point fuel injection systems, fuel transfer pumps, Fuel filters, fuel injection pumps and injectors. Electronic Injection system, Common Rail Direct Injection System.

**08 Hours**

**MODULE 5**

**AUTOMOTIVE EMISSION CONTROL SYSTEMS:** Different air pollutants, formation of photochemical smog and causes. Automotive emission controls, Controlling crankcase emissions, Controlling evaporative emissions, Cleaning the exhaust gas, Controlling the air-fuel mixture, Controlling the combustion process, Exhaust gas recirculation, Treating the exhaust gas, Air-injection system, Air-aspirator system, Catalytic converter.

**EMISSION STANDARDS:** Euro I, II, III and IV norms, Bharat Stage II, III, IV norms. Motor Vehicle Act

**08 Hours**

**Course Outcomes:** Student will be able

- To identify the different parts of an automobile and its working
- To understand the working of transmission and braking systems
- To comprehend the working of steering and suspension systems
- To learn various types of fuels and injection systems
- To know the cause of automobile emissions, its effects on environment and methods to reduce the emissions.

**TEXT BOOKS:**

1. Automobile engineering, Kirpal Singh, Vol I and II (12<sup>th</sup> Edition) Standard Publishers 2011
2. Automotive Mechanics, S. Srinivasan, (2<sup>nd</sup> Edition) Tata McGraw Hill 2003.

**REFERENCE BOOKS:**

1. Automotive mechanics, William H Crouse & Donald L Anglin (10<sup>th</sup> Edition) Tata McGraw Hill Publishing Company Ltd., 2007
2. Automotive mechanics: Principles and Practices, Joseph Heitner, D Van Nostrand Company, Inc
3. Fundamentals of Automobile Engineering, K.K.Ramalingam, Scitech Publications (India) Pvt. Ltd.
4. Automobile Engineering, R. B. Gupta, Satya Prakashan, (4th Edition) 1984.

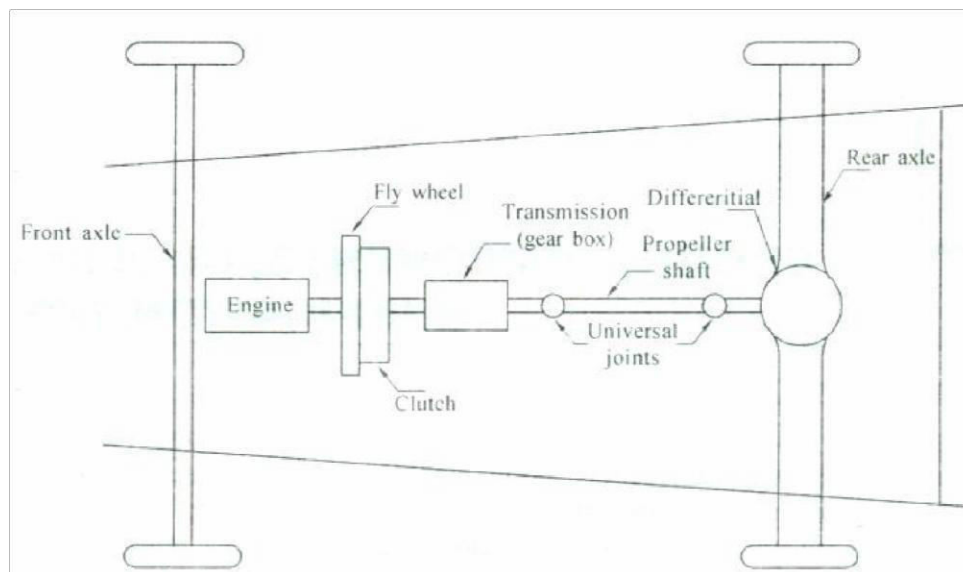
**UNIT – 1****ENGINE COMPONENTS, COOLING AND LUBRICATION SYSTEMS****INTRODUCTION**

An automobile is a self propelled machine used on the ground for transportation of passengers and goods from one place to another place. Automobile engineering or automotive engineering is the branch of engineering that deals with all types of automobiles like car, bus, truck, jeep, motor cycle etc., and the means of propelling them. Automobile or automotive refers to one which itself can move. The study of aero plane, helicopter, rocket etc., which fly in air, comes under Aeronautical engineering and marine engineering deals with ship, motor boat etc., which sail in water. Today, of course, the automobile vehicle has become a basic necessity and business of making and servicing automobiles has become one of the biggest businesses in the world.

I.C. Engines are used, in order to obtain motive power of the vehicle. In recent years, a huge changes are made in the design of automobiles to provide safety, ease of operation, reliability, comfort, less fuel consumption etc.

The Automobile consists of following basic components or parts. These are,

1. **The power plant:** It is nothing but the source of power or engine which provides motive power to perform various functions in the vehicle. The power plant generally consists of an internal combustion engine (I.C. Engine) which may be either of spark ignition (S.I), or of compression ignition type. Sometimes gas turbines are also used in certain cars.
2. **The basic structure:** This includes frame and wheel assembly, suspension system, axles, etc.
3. **The power train (transmission system):** The power train carries the power from the engine to road wheels. It consists of clutch, (for non-automatic transmissions) gear box, propeller shaft, differential.
4. **The super structure or car body.**
5. **The accessories** which include electrical system, radio, wind shield wiper, air conditioner etc.
6. **The controls:** It consists of steering system, Brakes, etc.



**Fig.: Layout of an automobile**

## S.I. AND C.I. ENGINES

Either S.I. or C.I. engines are used to obtain motive power to perform various functions in the automobile. Modern automotive engines vary greatly in size and design, but the operating principles are essentially the same as those of first models developed early.

In S.I. engine, a spark plug is an essential component which initiates combustion of fuel. The spark plug produces an electric spark of high energy, initiates ignition of fuel. In C.I. engine, the high temperature (greater than ignition temperature of the fuel) of compressed air ignites the fuel and this is called self or auto ignition. The fuel pump and fuel injectors are the essential components of C.I. engine.

## BASIC ENGINE TERMINOLOGY

**Top dead centre (TDC):** When the piston is at its top most position i.e., the position closest to cylinder head, it is called top dead centre.

**Bottom dead centre (BDC):** When the piston is at its lowest position i.e., the position farthest from the cylinder head, it is called bottom dead centre.

**Bore:** The 'Bore' is referred to the diameter of engine cylinder. It is denoted by 'D'.

**Stroke length or stroke:** The distance travelled by the piston between TDC and BDC is called stroke of the piston and is denoted by 'L'.

**Clearance volume:** When the piston is in TDC position the cylinder volume above it, is called

clearance volume and is denoted by 'Vc'.

**Swept volume or piston displacement:** The volume swept by piston while moving from TDC to BDC is called swept volume.

It is denoted by , Vs' .

$$V_s = \frac{\pi D^2}{4} L$$

**Compression ratio:** It is the ratio of volume above the piston at BDC to the volume above the piston at TDC. It is the ratio of total volume of the cylinder ( $V_s + V_c$ ), to the clearance volume. It is denoted by 'r'  $V_s + V_c$

$V_c$

For Petrol engines, it ranges from 8 to 12.

For diesel engines, it ranges from 15 to 24.

**Mean effective pressure:** As piston performs power stroke, cylinder pressure decreases. Thus it is required to refer an average effective pressure throughout the whole power stroke. It is expressed in bars.

**Power:** It is the work done in a given period of time. More power is required to do the same amount of work in a lesser time.

**Indicated Power (I.P.):** The power developed within the engine cylinders is called indicated power. It is expressed in kilowatts (kW). It is given by area under engine indicator diagram.

**Brake Power (B.P.):** This is the actual power available at the crank shaft. The indicated power minus various power losses in the engine like friction and pumping losses in the engine, gives Brake power. It is measured by using a Dynamometer and is expressed in kilowatts (kW).

### Engine torque

It is the force of rotation acting about the crank shaft axis at any given instant of time.

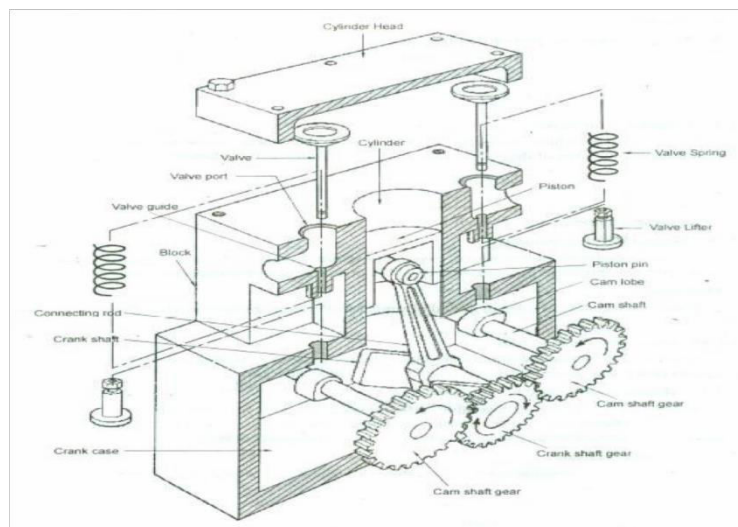
It is given by  $T = F \cdot r$ , where T = engine torque, Nm

F = force applied to the crank, N

r = effective crank radius, m

### MAIN COMPONENTS OF AN I.C. ENGINE

1. Cylinders
2. Piston
3. Connecting rod
4. Crank shaft
5. Valves and valve actuating mechanisms



## CYLINDERS

The cylinder is the main body of an engine in which piston reciprocates to develop power. It has to withstand very high pressure and temperature (around 2800°C). A cylinder block is one which houses the engine cylinders. If cylinder block and crank case are made integral, then the construction is called 'Mono block'. The cylinder material should be such that it should retain strength at higher temperatures, should be good conductor of heat and should resist rapid wear and tear due to reciprocating action of the piston. Generally cast iron is used. For heavy duty engines alloy steels are used.

For cooling water circulation, passages are provided around the cylinders. Cylinder block also carries lubrication oil to various components through drilled passages.

At the lower end of cylinder block, crank case is made integral with the block. At the top, cylinder block is attached with the cylinder head. It houses inlet and exhaust valves. Besides, other parts like timing gear, water pump, ignition distributor, fly wheel, fuel pump, etc., are also attached to it. The materials used for cylinder block are grey cast Iron and aluminium alloys.

The cast iron material has the following advantages.

1. It is relatively cheap and possesses good foundry properties.
2. The coefficient of thermal expansion of cast iron is low.
3. It has high machinability and does not wear too much.

The aluminium alloy cylinder blocks have the following advantages.

1. It has higher thermal conductivity than cast-iron. This results in efficient cooling of engine, so that higher compression ratios may be used.
2. The density of aluminium is about one third that of cast iron. It is a light material.
3. But considering lesser strength of aluminium, thicker sections have to be used to carry same

load. Further, in case of any loss of coolant, it cannot with stand high temperature and damage may occur. It wears more than cast iron.

The grey cast iron for cylinder block has the composition; carbon - 3.5 %, silicon - 2.5%, manganese - 0.65 %.

The Aluminium alloy cylinder blocks have the composition. Silicon - 11%, Manganese 0.5%, Magnesium 0.4%

### CYLINDER ARRANGEMENTS

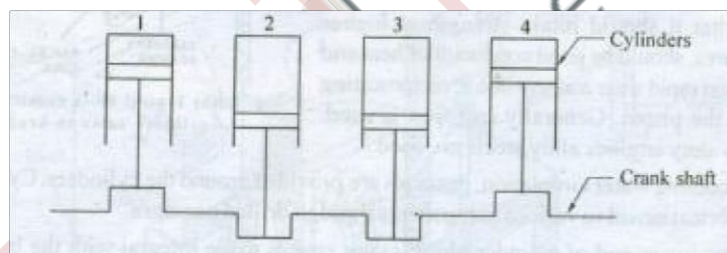
Multi cylinder engines are preferred over single cylinder engines due to reasons like

(i) Giving smooth torque output (ii) Lighter fly wheel (iii) Engine compactness (iv) Easy balancing. In multi cylinder engines, the arrangement of cylinders is very important. The following cylinder arrangements are used to give better performance of the engine. They are,

1. In line arrangement
2. Opposed cylinders type
3. V – engine
4. Radial engine

#### 1. In line arrangement

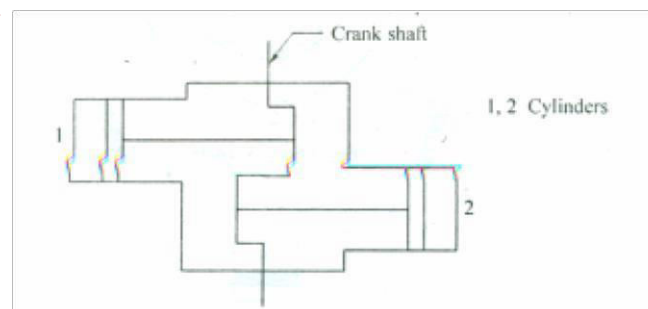
In this type, a number of cylinders are arranged in a line i.e., placed side by side vertically with a common crank shaft. In this type reciprocating forces are nearly balanced.



**Fig: Inline arrangement**

#### 2. Opposed cylinders type

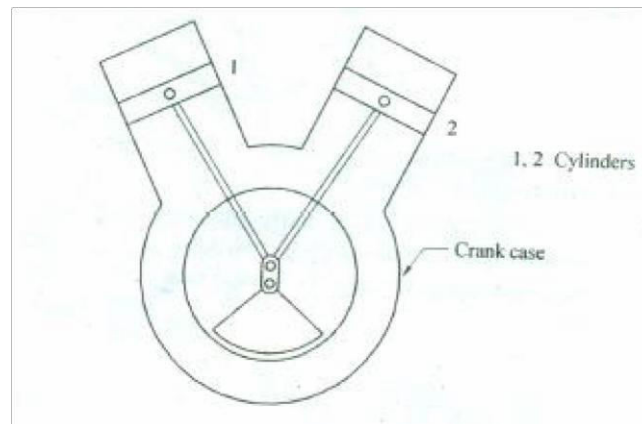
The two cylinders are arranged horizontally opposite to each other i.e., they are placed 180° apart facing each other with a common crank shaft. In this type, the reciprocating parts are perfectly balanced. As two cylinders are not in line, the force in connecting rod produces a rocking couple.



**Fig: Opposed type**

### 3. V - engine

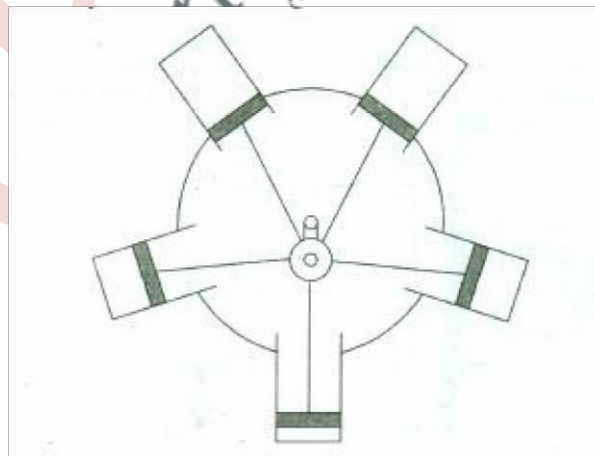
In this type, two cylinders are placed with their axes at  $60^\circ$ . The cylinders are arranged on two arms of letter “V” with a common crank case and crank shaft it is more compact and rigid and hence runs more smoothly at high speeds.



**Fig: V-engine**

### 4. Radial engine

In this type, a number of cylinders are arranged in radial fashion with a common crank shaft which is placed at the centre as in figure. The number of cylinders generally used is 5, 7, 9 etc., to obtain uniform firing intervals. This type is compact in size and gives higher Brake power per weight ratio. This is mainly used in air craft engines.



**Fig: Radial engine**

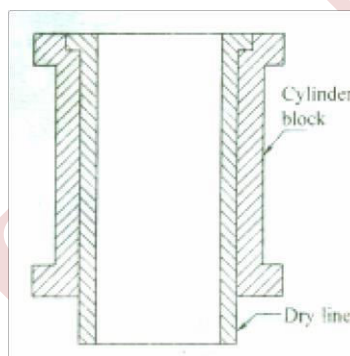


## LINERS (SLEEVES)

Engines make use of removable liners which are pressed into cylinder holes. The cylinder liners are in the form of barrels and used to reduce the cylinder wear and hence to increase cylinder bore life. The cylinder wear is more when cylinder block is made up of aluminium alloy. The liners can be inserted in the cylinder bore to reduce this wear. Whenever the liners worn-out, they can be replaced easily. Whenever a cylinder block is re-bored beyond allowable limits, liners are used to restore its original size. These are cast centrifugally and made up of special alloy iron containing silicon, manganese, nickel and chromium.

The liners may be further hardened by nitriding or chromium plating. In nitriding process, liners are exposed to ammonia vapour at  $5000^{\circ}\text{C}$  and then quenched. Chromium plating improves their resistance to wear and corrosion. There are two types of liners (1) Dry liners and (2) Wet liners.

### 1. Dry liners

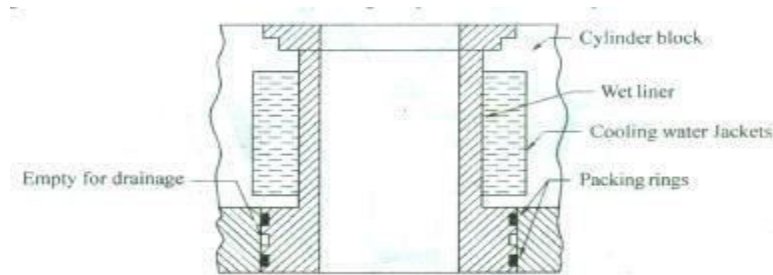


**Fig: Dry liners**

The dry liners are quite thin and use block metal to give it full length support. These liners are made in the form of barrel and a flange is provided at the top which keeps the liner in to position. It is necessary to machine the liner surface accurately both from inside and outside, as the outer surface of the liner makes contact with cylinder block. By shrinking the liner, it is put in to the cylinder bore. If the liner is too loose in the cylinder block, results in poor heat dissipation because of absence of good contact between them. This will result in higher operating temperature. Improper lubrication results in piston scuffing. Too tight a liner is even worse than the too loose case. This produces distortion of cylinder block, liner cracking, hot spots and scuffing.

### 2. Wet liners

Wet liner is pressed into bore of cylinder block and is supported at top and bottom only. These liners make direct contact with cooling water on the outside and hence do not require accurate machining on the entire outer surface. A flange is provided at the top which fits into the groove in the cylinder block. Three grooves are provided at the bottom, middle one is empty and top and bottom grooves are inserted with rubber packing's. For water leakage, drainage arrangements are provided from the middle groove. The wet liners are sometimes coated with aluminium on the outside to make the surface corrosion resistant.



**Fig: Wet liners**

## COMPARISON OF DRY AND WET LINERS

### Dry liners

1. They may be provided either in the original design or even after wards.
2. No leak proof joint is required.
3. Construction of cylinder block is not simple.
4. As dry liners does not make direct contact with cooling water, cylinder cooling is ineffective
5. Accurate machining of both block and outer liner surface is required, for perfect contact between them.

### Wet liners

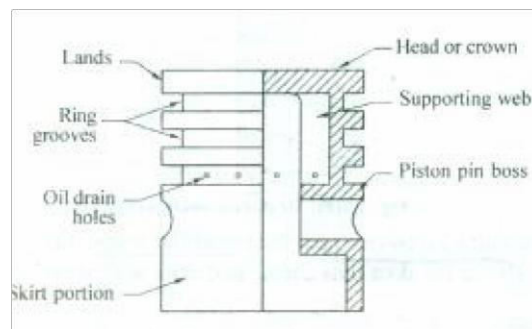
1. These have to be included in the original cylinder design.
2. A leak proof joint between the cylinder casting & liner is required.
3. Construction of cylinder block is simple.
4. As cooling water is in direct contact with liner, better cylinder cooling is possible.
5. Accurate machining on the outer liner surface is not necessary

## PISTON

The piston is a reciprocating part of the engine and converts the combustion pressure in the cylinder to a force on the crank shaft. Pistons are slightly smaller in diameter than the cylinder bore. The space is provided between piston and cylinder wall and is called "clearance". This 'clearance' is necessary to provide space for a film of lubricant. Pistons are made of aluminium alloys, cast steel, cast iron or chrome nickel. Aluminium alloy pistons are used in modern automobiles.

### Functions

1. It forms a seal within the cylinder to avoid entry of high pressure gases from combustion chamber into crank case.
2. It transmits the force of explosion to the crank shaft.
3. It acts as a bearing for the gudgeon pin.



**Fig: Typical I.C, engine piston**

A typical I.C. engine piston is as shown in figure. The piston almost has the shape of an Inverted bucket. The top portion of the piston is called head or crown. In some engines, pistons may be specially designed to form desired shape of the combustion chamber. At the piston top, few grooves are cut to accommodate the piston rings and the bands left between the grooves are known as "Lands". They support the rings against gas pressure. The portion below rings is called piston skirt. The skirt is provided with bosses on the inside to support the piston pin.

The Aluminium alloy pistons have the following advantages over cast iron pistons.

1. Lighter in weight, allowing higher rpm. [It is 3 times lighter than C.I. piston which is desirable from inertia point of view].
2. It has higher thermal conductivity allowing the use of higher compression ratio.

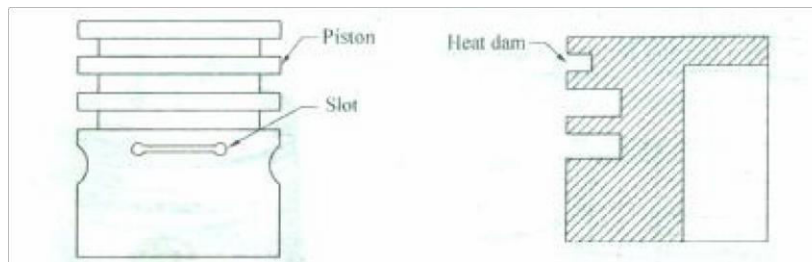
The aluminium alloy pistons have the disadvantages like,

1. It is not as strong as cast iron; hence thicker sections have to be used.
2. Aluminium alloy is soft, fine particles of lubricating oil become embedded in it. It causes a sort of grinding.
3. It causes a sort of grinding or abrasion of the cylinder walls thus decreases cylinder life.
4. The main drawback of using aluminium alloy pistons with cast iron cylinders is their unequal coefficient of expansion which causes engine slap.

### CONTROL OF PISTON SLAP

The use of Aluminium alloy piston with cast iron cylinder has a drawback of engine slap. If cold clearance is kept just sufficient, there is danger of seizure at higher operating temperatures and if it is kept larger, the engine knocks or slaps when cold. Different methods are used to overcome this difficult, they are,

1. **Cutting horizontal slot:** This method keeps the heat away from the lower part of the piston. By cutting horizontal slot in the portion just below the oil control ring, skirt portion does not become very hot and hence does not expand so much.



**Fig: (a) Piston with horizontal slot      Fig: (b) Heat dam construction**

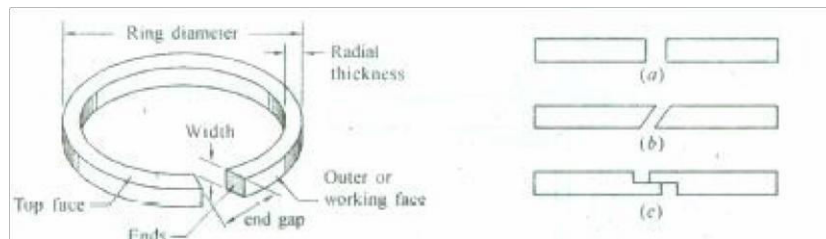
2. **Heat dam:** By making heat dam i.e., by cutting a groove near the top of the piston, the heat flow to lower part of piston can be reduced. Hence the skirt runs cooler and does not expand too much.
3. **Vertical or T slot:** In this type, the top of T tends to retard the heat transfer from head to the piston skirt. The vertical slot allows the skirt of the piston to close when heated i.e., it allows piston skirt to expand without increase in diameter. However mechanical strength is decreased on account of slot. Due to presence of this slot, the diameter reduces permanently which increases engine slap. Hence fully split skirts are not used.



4. **Split skirt:** In a split skirt piston, skirt is either partially or completely split. When the piston warms and begins to expand, it cannot find in the cylinder since the skirt merely closes the split.
5. **Tapered pistons:** Sometimes the pistons are turned taper, the crown side being smaller in diameter than the skirt end. As crown portion is exposed to higher temp than skirt, that side expands more than skirt and piston diameter becomes uniform under operating conditions.
6. **Special alloy pistons:** Special alloy having coefficient of expansion nearly equal to that of cast iron (or low value) have been used in the manufacture of pistons. One such alloy is "LOEX" alloy It is an alloy having 12-15% silicon, 1.5-3% nickel and 1 % of each of magnesium and copper Such pistons are costlier.
7. **Wire wound pistons:** A band of steel wire is wound between the piston pin and oil controlling, thus restricting the expansion of skirt.
8. **Bimetal pistons:** The pistons are made from both steel and aluminium. Steel is used to manufacture skirt portion and aluminium alloy cast inside to form piston head and piston pin bosses. For steel, coefficient of thermal expansion is quite small, piston will not expand much and hence smaller cold clearances can be maintained.

## PISTON RINGS

Piston rings are located towards the top of the piston. The top two piston rings are called compression rings and are designed to maintain cylinder pressure. The bottom ring is called oil ring, (may be 1 or 2 in number) they scrape the excess oil from the cylinder walls and return it through slots to the piston ring grooves. A properly constructed and fitted ring will rub against the cylinder wall with good contact all around the cylinder. The ring will ride in grooves that are cut into the piston head.



The material generally used for piston rings is fine grained alloy cast iron containing silicon and manganese. It has good heat and WCi.1resisting qualities. Rings with molybdenum filled face have also been introduced recently. Alloy steels are also used. The number of rings vary depending on the engine design. It varies from two to four.

Generally the ring is cast and machined and put in position in the ring grooves. It exerts uniform pressure against the cylinder walls. A gap is to be cut at the ends so that while inserting the ring, it can be expanded, slipped over the piston head and released in to the ring groove. The gap is almost closed when the piston is inside the cylinder.

### Functions:

1. It forms a seal so that high pressure gases from the combustion chamber will not escape into the crank case.
2. It provides easy passage for heat flow from piston crown to the cylinder walls.
3. It maintains enough lubrication oil cylinder walls throughout the stroke length. This reduces ring and cylinder wear. The thickness of oil film is to be controlled and the oil should not go up into the combustion chamber where it would burn and produces carbon deposits.

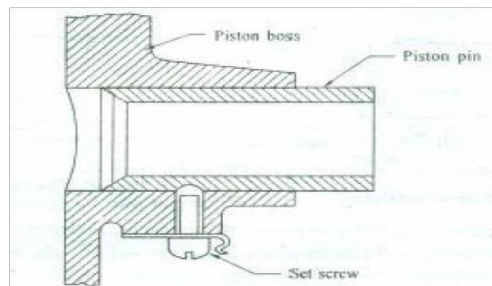
## PISTON PIN

Piston pin is also known as wrist pin or gudgeon pin, used to connect Piston and connecting rod. It transfers combustion chamber pressure and piston forces to the connecting rod. It is in tubular shape to provide adequate strength with minimum weight. It passes through the piston bosses and small end of the connecting rod. It is made of low carbon case hardened steel (carbon - 15%, silicon - 0.3%, manganese - 0.5%).

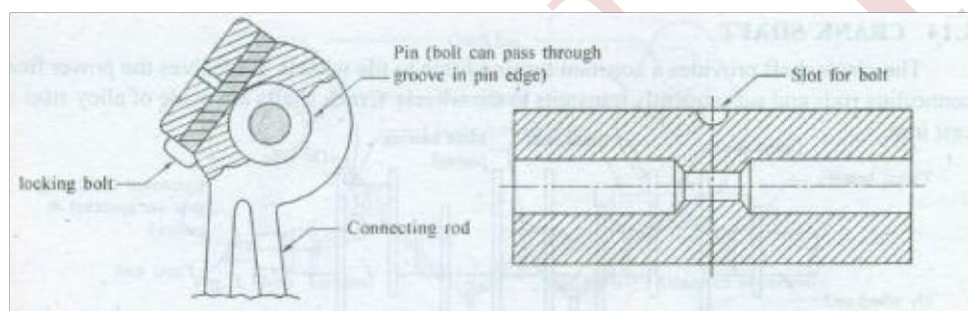
Piston pins are installed and secured to provide a bearing action in the following three ways.

1. The pin is fastened to the piston by set screws through the piston boss and has a bearing in the connecting rod small end. This permits the connecting rod to swivel as required by the combined reciprocal and rotary motion of piston and crank shaft.

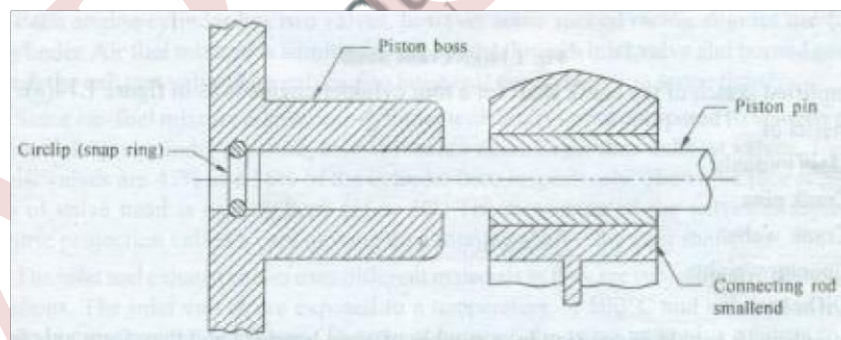
2. The piston pin is fastened to the connecting rod by means of a bolt and uses the piston bosses for bearings. Nowadays, bolt has been replaced by interference fit.
3. A floating pin is used which is free in both the connecting rod and piston. This arrangement is most commonly used. Circlips are used to prevent end movements.



**Fig: (a) Piston pin fastened to piston**



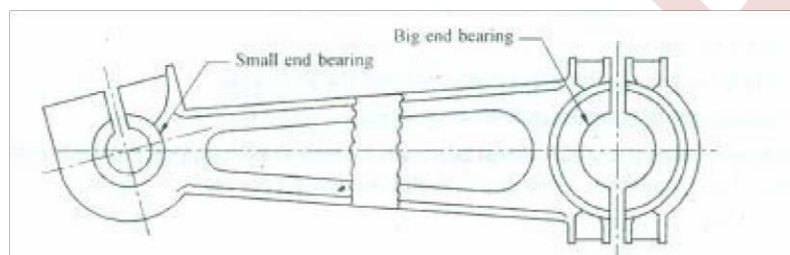
**Fig: (b) Piston pin locked to connecting rod**



**Fig. (c) Floating Piston Pin**

### CONNECTING ROD

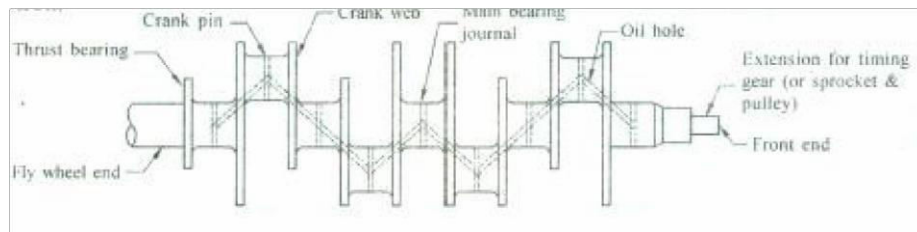
The connecting rods are used to connect pistons to the crank shaft. The upper end of rod oscillates (swing back and forth) while the lower end or big end rotates (turns). It converts reciprocating motion of the piston into rotary motion of the crank shaft. The upper end of the rod has a hole through it for the piston pin. The lower end must be split type. A combination of axial and bending stresses act on the rod in operation. The axial stresses are due to gas pressure in the cylinder and inertia force caused by reciprocating motion. Bending stresses are caused due to centrifugal effects. Connecting rods are manufactured by casting and forging processes. The rod has an I-beam cross section to provide maximum rigidity with minimum weight. Generally rods are made by drop forging of steel or duralumin and also cast from malleable cast iron.



**Fig: Connecting Rod**

**CRANK SHAFT**

The crank shaft provides a constant turning force to the wheels. It receives the power from connecting rods and subsequently transmits to the wheels. Crank shafts are made of alloy steel or cast iron.



**Fig: Crank Shaft**

A simplified sketch of the crank shaft for a four cylinder engine is as-in figure. It consists of

1. Main journals
2. Crank pins
3. Crank webs
4. Counter weights
5. Oil holes

The crank shaft is held in position by a number of main bearings and they form axis for the rotation of crank shaft. Their number is always one more or one less than the number of cylinders. The crank pins are the journals for the connecting rod big end bearings and are supported by the crank webs. The distance between the axis of the main journal and the crank pin centre lines is called 'crank through'. Oil holes are drilled from main journals to the crank pins through 'crank webs' for lubricating big end bearings.

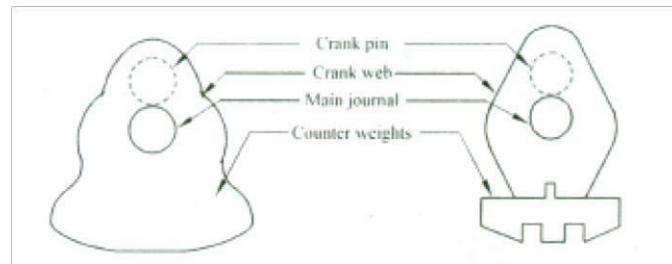
When the engine is running, due to rotation of both crank shaft and connecting rod big end, each crank pin will be subjected to centrifugal forces. This will tend to bend the crank shaft. To avoid this counter weights are used. The counter weights are formed as integral part of the crank web or may be attached separately as in fig.

On the front of the crank shaft, it is mounted with

- i. Timing gear or sprocket which drives the crank shaft.
- ii. Vibration damper
- iii. Pulley for driving the water pump, fan and the generator. On the rear end, it is mounted with a fly wheel.

On the main bearing journals, thrust bearing is located so as to support the loads in the direction of shaft axis. Such loads may arise due to clutch release forces etc.



**Fig: Integral****Fig: Attached separately**

## VALVES

Each engine cylinder has two valves however some special racing engines use four valves per cylinder. Air fuel mixture is admitted to the engine through inlet valve and burned gases escape through the exhaust valve. The valves also must seal the combustion space tightly. Since air-fuel mixture admits into cylinder with lesser speed compared to velocity of exhaust gases which leaves under pressure, inlet valves are made larger than exhaust valves. The inlet and exhaust valves are 45% and 38% of the cylinder bore respectively. The valve face angle with the plane of valve head is usually kept 45° or 30°. The movement of the valves is actuated by an eccentric projection called a cam moving on a rotating shaft - the cam shaft.

The inlet and exhaust valves use different materials as they are subjected to different operating conditions. The inlet valves are exposed to a temperature of 5000 °C and exhaust valves have to operate in more severe conditions. To prevent burning, the valve must give off heat to the valve guide and to the valve seat.

Silicon - Chrome steel (Carbon - 0.4%, nickel- 0.5%, manganese - 0.5%, silicon - 3.5%, chromium - 8%) is the material used for inlet valves. For exhaust valves, molybdenum is added to it. Recently austenitic steels are used for exhaust valves. To make it corrosion resistant, the valve may be coated with aluminium.

The engine valves may be classified into

1. Poppet valve
2. Sleeve valve
3. Rotary valve

Poppet valve is universally used for automobile engines.

### Poppet Valve

Its name is derived due to its motion of popping up and down. As the shape resembles a mushroom, this valve is also called as 'mushroom' valve. It consists of a head and a stem. It is simple in construction and self centering. Sealing efficiency maintenance is much easier with this poppet valve.

### Valve Cooling

It is necessary to cool the exhaust valve directly or indirectly as it reaches very high temperature i.e. about 750°C or even more. Therefore cooling of exhaust valves becomes very important and is done by providing cooling water jackets near the valve.

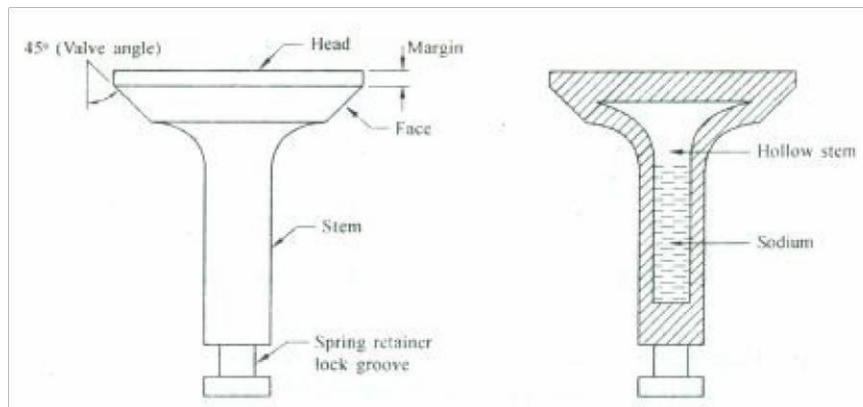


Fig: (a) Poppet Valve

Fig: (b) Sodium Cooled Valve

In some heavy duty engines and air craft engines, sodium cooled valves are used. These valves have a hollow head and stem which is partly filled (about 40% volume of the stem) with sodium or a mixture of salts. Sodium is a high conductivity metal which melts at  $105^{\circ}\text{C}$ . It is in liquid state at operating temperatures. When the valve is in operation, the up and down movement of sodium transfers the heat to the stem, valve guide, and cylinder block and to the cooling water circulating in water jackets. This arrangement cools the valve by about  $100^{\circ}\text{C}$ . The sodium goes up and absorbs heat from valve head and while coming down transfer heat to stem etc.

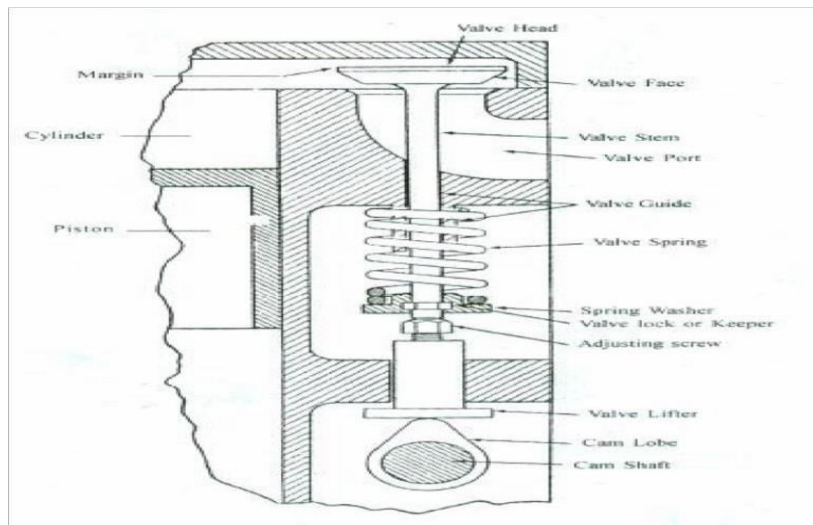
## VALVE ACTUATING MECHANISMS

The valves located in the cylinder head are operated by an eccentric projection called cam which is driven at half the crank shaft speed. Different valve operating mechanisms are used and are classified into

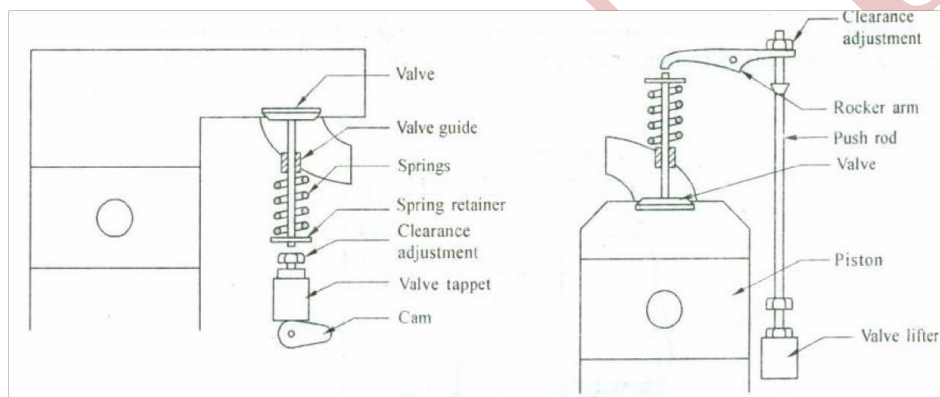
- a) Side valve mechanism
  - b) Over head valve mechanism
  - c) Over head inlet and side exhaust valve mechanism.
- a) **Side Valve Mechanism:** This mechanism is used for L-head engines. In this type, inlet and exhaust valves are mounted in a single row and operated from the same crank shaft. Nowadays, this mechanism is obsolete due to complicated shape of the combustion chamber which leads to detonation.
  - b) **Over Head Valve Mechanism:** This mechanism is suitable for I and F head designs. The cam operates the valve lifter which in turn actuates the push rod. This action rotates the rocker arm about a shaft or a ball joint in some designs, to cause one end to push down on the valve stem to open the valve.

### Advantages

- a) Higher volumetric efficiency.
- b) Leaner air-fuel mixtures can be burnt.
- c) Higher compressions can be used.

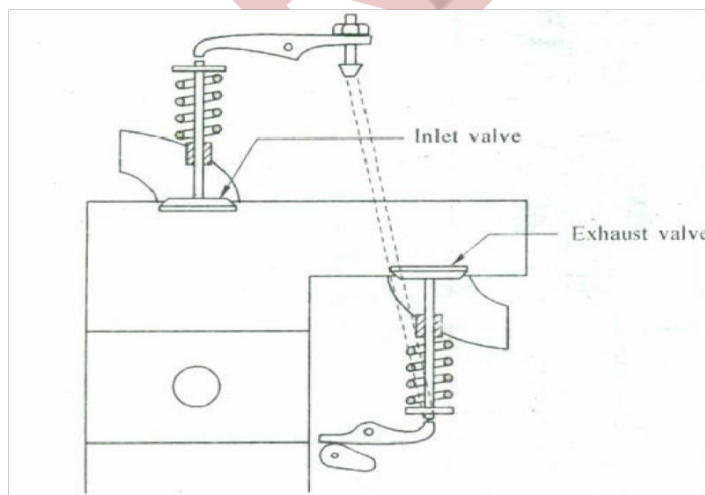


**Fig: Detailed view of side valve mechanism**

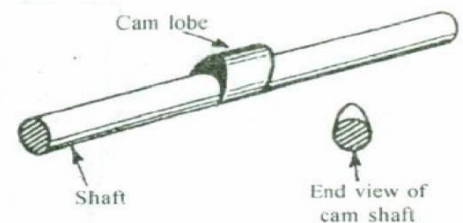


**Fig: (a) Side valve mechanism.**

**Fig: (b) Over head valve mechanism**



**Fig: (c) Overhead inlet and side exhaust**



**Fig: (d) Cam shaft valve mechanism**

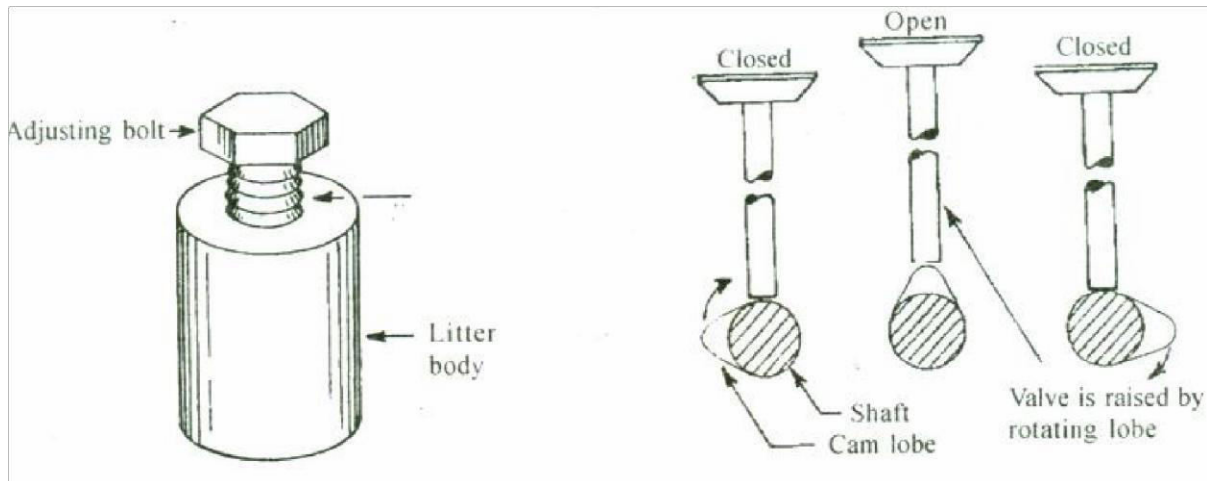


Fig: (e) Valve lifter

Fig: (f) Valve operation

### COMPONENTS OF THE VALVE ACTUATING MECHANISMS

The essential components of a valve actuating mechanism are

- Cam Shaft:** It provides a means for opening the valves. It carries one cam for each valve to be operated. It also provides a drive for the ignition distributor and the mechanical fuel pump. The cam shaft is driven by the crank shaft by means of timing gears or chain drive at half the speed of crank shaft. It is forged from alloy steel or cast from hardenable cast iron and is case hardened.
- Valve tappet (valve lifter or cam follower) :** It follows the shape of the cam lobe on the cam shaft and hence converts angular movement of the cam in to a reciprocating motion. This is placed slightly eccentric with cam to make the cam wear uniform and is located between push rod and cam.
- Push Rod:** This is placed between valve tappet and rocker arm and transmits reciprocating motion of valve tappet to the rocker arm. Push rods are made of steel and may be either solid or hollow. Hollow push rod is lighter and results in reduced inertia forces. It provides a passage for the oil to lubricate the valve actuating mechanism.
- Rocker Arm:** It may be solid or hollow and changes (reverse) the upward motion of the push rod to down ward motion of the valve and vice versa. It is made of steel (forged or stamped) or iron (cast).

### VALVE AND PORT TIMING DIAGRAMS

The valve timing diagram is one which represents position of crank when the valves (both inlet and exhaust) opens and closes.

When a valve opens or closes, how fast it will rise, how long it will stay open and how fast it will close depends on the shape of cam lobe and position of cam shaft in relation to the crank shaft.

The exact number of degrees that a valve will open or close before top or bottom dead centre varies widely, depending on engine design. This diagram shows the crank position when various operation (suction, compression etc.) in an engine begin and end.

Theoretically, we know that inlet valve should open when piston is at TOC before suction and close when piston is at BOC after performing suction stroke. The exhaust valve should open when piston is at BOC before exhaust stroke and should close at the end of exhaust, when the piston is at TDC to complete a cycle. But the valves require a finite period of time to open and close without abruptness. Therefore, a slight lead time is necessary for proper operation of the engine.

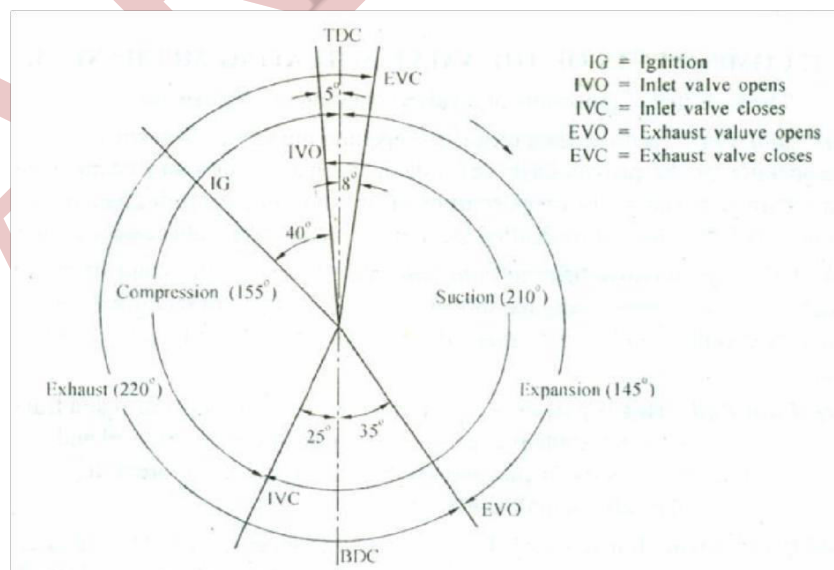
The actual valve timing diagrams for a 4-stroke Spark-Ignition engine and diesel engines are as shown in figures.

**a) Inlet Valve:** The inlet valve should open few degrees prior to the arrival of the piston at TOC during exhaust stroke of previous cycle. This ensures full open of the valve and entry of fresh charge in to the cylinder as soon as the piston begins to descend. If the inlet valve closes at BOC, the cylinder would receive less charge. To avoid this inlet valve is kept open for few degrees of rotation of the crank after suction stroke i.e., the inlet valve closing is delayed. As engine speed increases, the inlet valve closing is delayed longer.

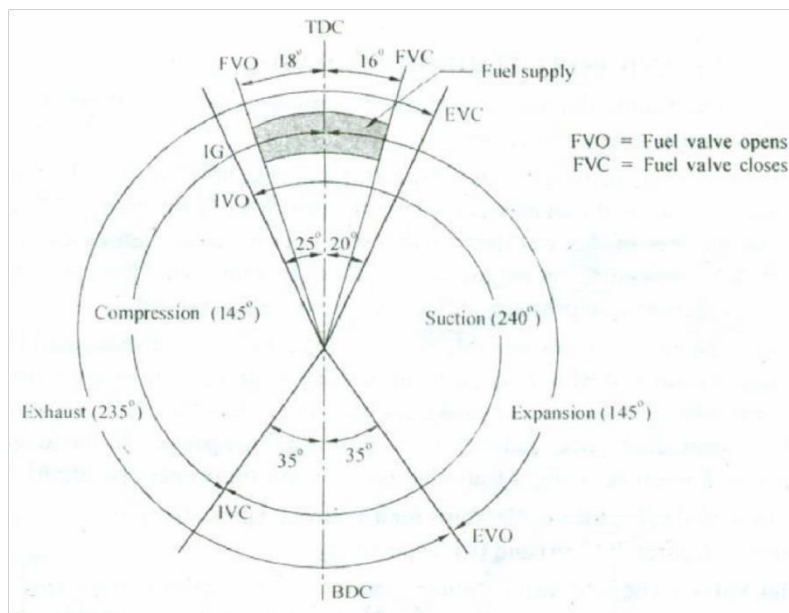
**b) Exhaust Valve:** It is necessary to open the exhaust valve before the piston reaches end of expansion stroke. Even though this wastes some of the force of expansion, it removes greater part of burned gases, reducing the amount of work to be done by the piston on its-return stroke.

It is seen from the valve timing diagram that both the valves (inlet and exhaust) overlap for 13 degrees of crank rotation. In petrol engine, more overlapping is not advisable, because air and fuel mixture may pass out with the exhaust gases and is uneconomical. But in diesel engine, only air is drawn during suction stroke and hence such problem will not arise.

This overlapping helps in scavenging, resulting in an increased output.

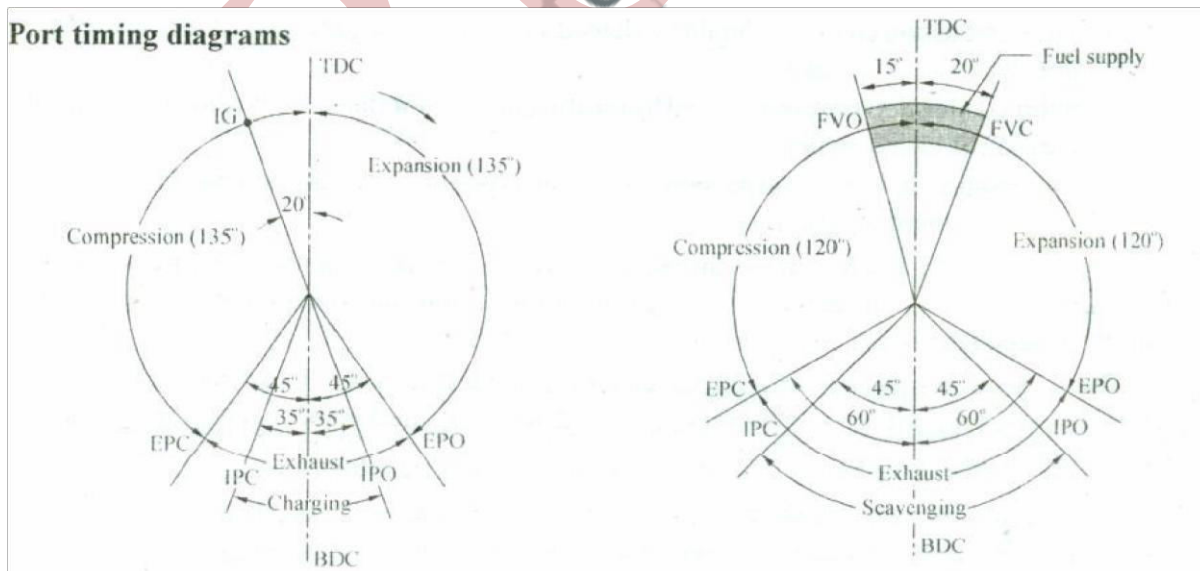


**Fig: (a) Actual valve timing diagram for a 4S - S.I. Engine**



**Fig: (b) Actual valve timing diagram for a 4S - Diesel engine**

**1. Ignition:** There is always a time lag between the spark and ignition of the charge. The charge takes some time to burn after giving the spark. Therefore, it is necessary to produce the spark early to obtain proper combustion without losses. The angle through which the spark is given earlier is 'Ignition advance' or 'angle of advance'. In diesel engines, the opening of fuel valve before TDC is necessary for better evaporation and mixing of the fuel. There is always lag between ignition and supply of fuel results in early supply of fuel.



**Fig: (a) Port timing diagram for 2S petrol engine**

**Fig: (b) Port timing diagram for 2S diesel engine**

**IG Ignition**

**EPO - Exhaust port opens EPC - Exhaust port closes**

**IPO (TPO) -Inlet or transfer port opens IPC (TPC) -Inlet or transfer port closes FVO - Fuel valve opens FVC Fuel valve closes.**

The port timing diagrams for two stroke petrol and diesel engines are as shown in figures (a) and (b).

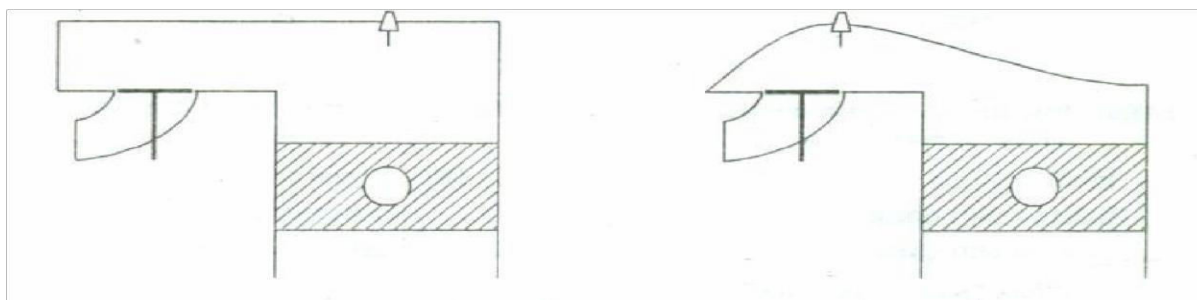
The main difference between these two is, the charging and scavenging period in the diesel engine is ( $90^\circ$ ) greater than that of petrol engine ( $70^\circ$ ). This is because there is no danger of loss of fuel during scavenging of diesel engine.

**COMBUSTION CHAMBER DESIGNS FOR S.I. AND C.I. ENGINES****(a) In S.I. Engines**

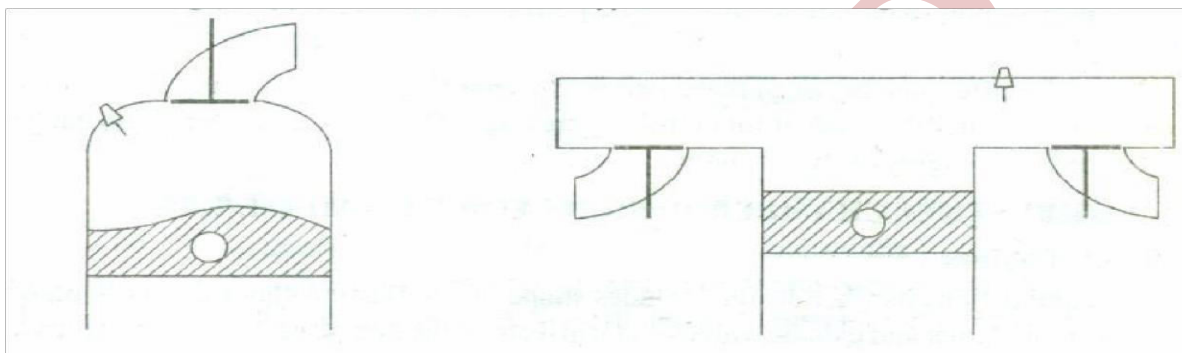
The combustion chamber design includes shape of combustion chamber, spark plug location and deposition of inlet and exhaust valves and it affects on the engine performance and its knocking properties.

The three basic requirements of a SI Engine combustion chamber are high power output with minimum octane requirement, High thermal efficiency and smooth engine operation. These requirements can be achieved by the following design principles.

- a) Largest possible valve should be provided with ample clearance to obtain high volumetric efficiency.
- b) The heat flow should be minimum in the zone around sparking plug to obtain high thermal efficiency.
- c) To prevent detonation the length of flame travel from the spark plug to 'the farthest point in the combustion space should be as short as possible. This involves spark plug location, valve position, shape of the combustion chamber.
- d) The combustion chamber should be shaped such that the largest mass of the charge burns in a short time after ignition.
- e) Short combustion time is achieved by creating the highest flame front velocity through the creation of high turbulence.
- f) The compression ratio can be increased as far as possible for a given type of fuel to obtain maximum thermal efficiency.
- g) The figure a, b, c & d shows different types of combustion chambers and are designed to obtain high combustion rate at the start, a high surface to volume ratio near the end of burning and centrally located spark plug.
- h) The T-head design was introduced in ford T model in 1908. It had the disadvantages
  - (i) Having two cam shaft;
  - (ii) Being very prone to detonation, the distance across the combustion chamber was long.



L-head types



I-head

T-head

Fig: Design of combustion chambers in S1 engines

Side valve engine was introduced in petrol engines, in 1910 - 30. In this type valves are placed side by side. It is easy to lubricate the valve mechanism. It had the defects like lack of turbulence, extremely prone to detonation, slow combustion process etc.

**(b) In C.I. Engines**

There are many types of combustion chambers used in C.I. Engines. Anyone of these combustion chambers may produce good results in one field of application, but poor results or less desirable results in another application

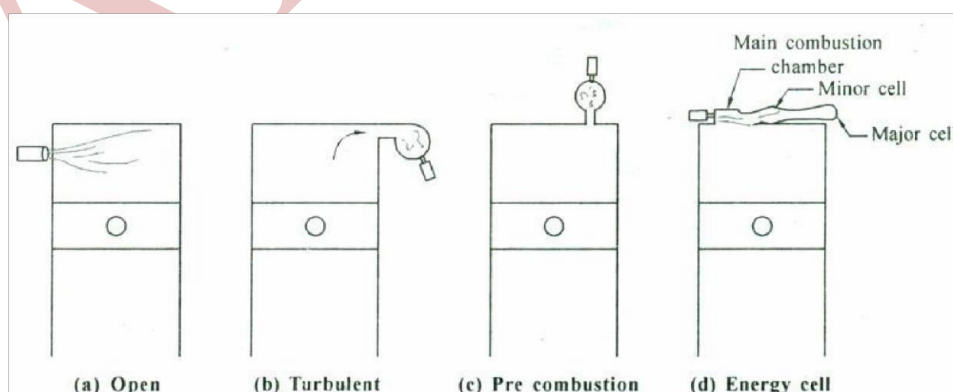


Fig: Design of combustion chambers in CI engines

The open combustion chamber is a non-turbulent type. This is ordinarily used on low speed engines. Less costly fuels with longer ignition delay may be used with this design.



The turbulent chamber, pre combustion chamber and energy cell are variations of turbulent type of chamber. All these types tend to exhibit the same general characteristics.

This type depends on turbulence to produce the required mixing of fuel and air. This does not require as much excess air as non turbulent type. These are suitable for variable speed operation and also produce smoother operating engines.

### METHODS FOR SWIRL GENERATION

In C.I. engine fuel is injected near the end of compression and mixing of fuel and air take place inside the combustion chamber. Thus combustion chamber has to perform duty of a carburetor, within a period of some 20 to 35 degrees of crank angle. The combustion chamber design should be such that it has to provide proper mixing of fuel and air in a short time. To achieve this, an organized air movement, called air swirl is provided to produce high relative velocity between the fuel droplets and air. Different methods are used to generate air swirl in a CI engine combustion chamber. They are

- a) By directing air flow during its entry to the cylinder known as induction swirl. This method is used in open combustion chambers.
- b) During compression, air is forced through a tangential passage in to a separate swirl Chamber known as compression swirl. This method is employed in swirl chambers.
- c) By use of the initial pressure rise due to partial combustion to create swirl turbulence, known as combustion induced swirl. This method is used in pre combustion chambers and air cell chambers.

Open combustion chamber is one in which the combustion space is essentially a single cavity with little restriction and hence there are no pressure differences between different parts of the chamber during the combustion process. There are many designs of open combustion chambers used in conjunction with induction swirl. In a 4S engine induction swirl can be obtained by

- i) Careful formation of the air intake passages
- ii) By making or shrouding a portion of the circumference of the inlet valve.

In a 2S engine, the induction swirl is created by suitable inlet port forms. The induction swirl is generally weak in intensity.

A swirl chamber or divided combustion chamber is one in which the combustion space is divided into two or more compartments, between which there are restrictions or throats small enough so that considerable pressure differences occur between them during the combustion process. In compression swirl a very strong swirl which increases with speed is generated. Due to strong swirl, a single orifice injector with low injection pressure is required. Also there is greater utilization air, results in higher mean effective pressure.

The turbulent combustion chambers using combustion induced swirl are not much favoured now a days. In this type, the two important designs are pre combustion chamber and air cell combustion chamber. The pre combustion chamber uses single hole pintle type of nozzle and the initial shock of combustion is limited to pre combustion chamber only. It has multi fuel capability without any modification in the injection system. The air cell chamber design is smooth running and easy starting.

## ENGINE RATING

All engines are rated in Power - the measure of rate at which they can do work. There are two ways of measuring engine power - (1) The power developed by expansion of gases in the cylinder can be determined by using indicator cards (indicated power) ; (2) By means of measuring instruments like a prony brake or a dynamometer, the actual power which an engine delivers can be determined (brake power).

The general methods used to define rated power of an automobile engine are

- 1) Maximum load carried by the engine continuously. This load is indicated on the basis of mean effective pressure kpa. for petrol engines M.E.P varies from 640 kpa.
- 2) Maximum power developed by the engine. In this case the engines are rated in terms of their maximum capacity. i.e, maximum B.P. that can be developed.
- 3) Using conventional formula (RAC Ring). For taxation purposes, the Royal Automobile club made certain assumption for finding out B.P. for a 4S automobile engines. This B.P. is much less than obtained in case (2) represents the RAC rating of engine.

The assumptions are

Piston Speed:- 1000 ft/min mep - 90 psi

Mechanical efficiency – 75%

$B_p - (d^2n)/2.5$  Where d = diameter of the cylinder, inches n = number of cylinders.

### Engine Components

- 1) Cylinders
- 2) Oil Pan
- 3) Inlet and exhaust manifold
- 4) Cylinder liners
- 5) Piston
- 6) Piston ring
- 7) Piston pin
- 8) Connecting rod
- 9) Crank shaft

### Materials & their composition

- 1) Grey cast iron (carbon present in the form of flakes of graphite which makes it more Wear and corrosions resistant) carbon - 3.5%, silicon -2.5%, manganese - 0.65%. Carbon serves to provide graphite which improves lubrication; silicon provides wear resistance while manganese increases the strength and toughness.
- 2) Aluminium alloys-silicon - II %, manganese - 0.5%, magnesium - 0.4%. Silicon reduces expansion and increases strength and wear resistance, manganese and magnesium improves strength of aluminium structure. Pressed steel sheet Cast Iron Special alloy iron containing silicon, manganese, nickel and chromium Cast-iron, aluminium alloy containing silicon.

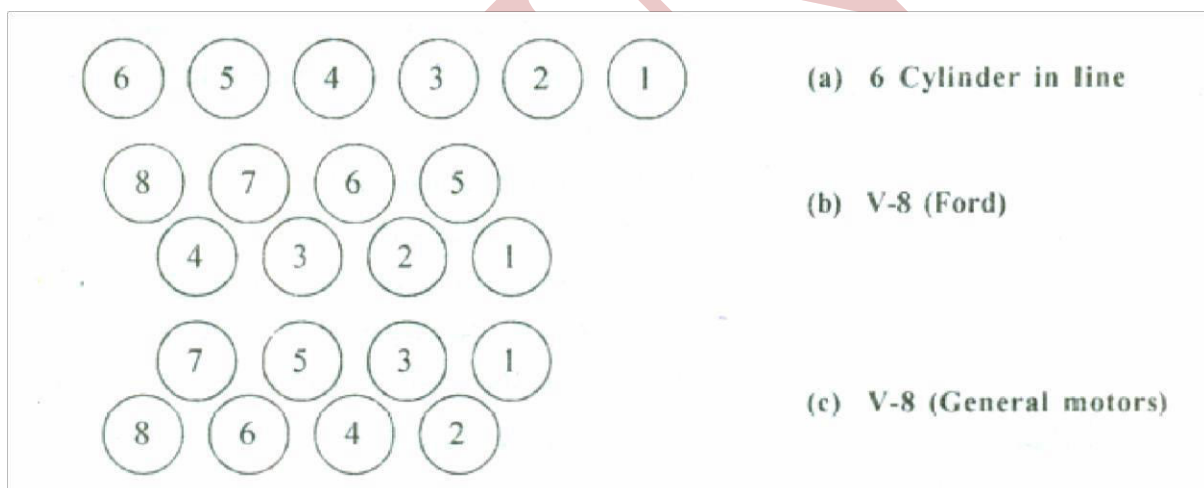
Special alloy (La - ex alloy).

Fine- grained alloy cast iron containing silicon and manganese, chromium plated types. Low carbon case hardened steel; carbon-I 5%, silicon - 0.3%, manganese - 0.5% and remainder iron

- Drop forging of steel or duralumin
- Cast from malleable or spherical graphite cast iron. Cast steel, S.G. Iron (in case of casting) SAE steels, 1045 and 3140, chrome-vanadium and chrome molybdenum steels (forging)

### NUMBERING OF ENGINE CYLINDERS

In multi cylinder engines, the power strokes in various cylinders are not continuous one after the other, to obtain better engine performance. For example in a 4-cylinder engine the order is not kept as 1-2-3-4, but is kept as 1-3-4-2 or 1-4-3-2. For a 6-cylinder inline engine, the firing order is 1-5-3-6-2-4 and in a V-8 engine it is 1-5-4-2-6-3-7-8. In case of in line engines, cylinders numbering is done from front to the rear, the number one being at the front as in fig. (a). In V engines adopted by Ford motor company, one group of cylinders are numbered 1 to 4 with number 1 at the front as in fig. (b). similarly other row is numbered from 5 to 8, with 5 at the front end. In another type used by general motors' the cylinders numbering depends on the connecting rods arrangement, starting with number one at the front of the crank shaft [fig. (c)].



**Fig numbering of engine cylinders**

### ENGINE POSITION

The engine may be conveniently placed on the chassis in different positions as given below

#### (a) Front Position

In most of the lighter vehicles (both private and commercial), the engine is placed at the front and conventionally rear wheel drives are used. In some of the vehicles drive is also given to front wheels only. The engine position remains 'the same in heavy commercial vehicles, but the cab is brought forward over the engine to increase the pay load. The engine position at the front with rear wheel drive system needs greater length of propeller shafts, as it has to run from front (engine side)

to the rear (road wheels) of the vehicle. Also, in this system, the number of universal joints required are more.

### (b) Rear Position

In this system, the engine is mounted close to the back axle, thereby reducing the length of drive from engine to the axle. In this position, length of propeller shaft required is reduced and is suitable for small cars. This position provides more space to the passengers, results in economy of drive parts and also better engine service is possible. The fixing of gear shift lever, oil gauge and fuel gauges, accelerator linkage is very complicated due to missing of natural draft of air during forward motion of vehicle to the radiator.

The major portion of total weight of the vehicle lies on the rear wheels and hence helping in traction up the hill. With rear position of the engine, the luggage has to be accommodated at front, near the driver seat, which is a problem as wheel arches are already occupied a large place there.

### (c) Under Floor Position

This position of the engine is in the centre, under the chassis and is used in public service vehicles and heavy lorries. This position of the engine eliminates the heat and noise in the cab. In this position the advantages of gravitational flow of the fuel and lubricants are also taken. It also reduces length of the drive shaft from engine to rear axle. The engine repairs and hence maintenances are easy.

**ENGINE COOLING:** In the process of converting thermal energy in to mechanical work, as a result of combustion, high temperatures are produced. This heat is transferred to the cylinder walls, piston and valves. Unless these parts are adequately cooled, the engine will be damaged. A part of total fuel energy is converted in to mechanical work and rest is rejected in the form of

1. Heat from engine surface by combined action of conduction, convection and radiation.
2. Heat lost to exhaust.
3. Heat rejected in to the coolant.

In general, engine converts 30 percent of total fuel energy in to useful work, 30 percent is lost in exhaust heat and cooling system has to remove 30 percent heat energy to maintain engine temperature. Some energy lost occurs in friction, compression etc. The cooling system maintains temperature of engine components within certain limits and increases engine performance. Cooling beyond optimum limits is not desirable as it decreases the overall efficiency due to following reasons.

1. More lost of heat to cylinder walls causes decrease, in thermal efficiency.
2. Combustion efficiency decreases due to less evaporation of fuel at lower temperature.
3. At lower temperature, viscosity of lubricant increases and results in more frictional losses. This reduces overall efficiency.

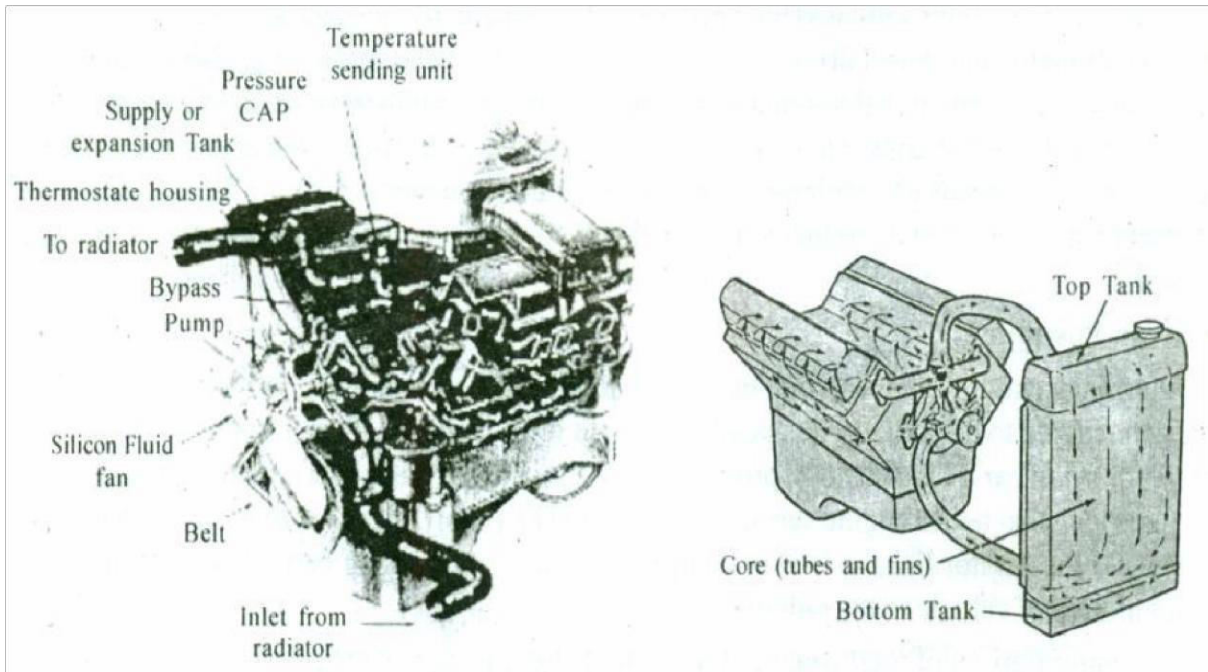


Fig (a): Coolant flows through an engine Fig (b) : Coolant flow path in a system using a down - flow radiator.

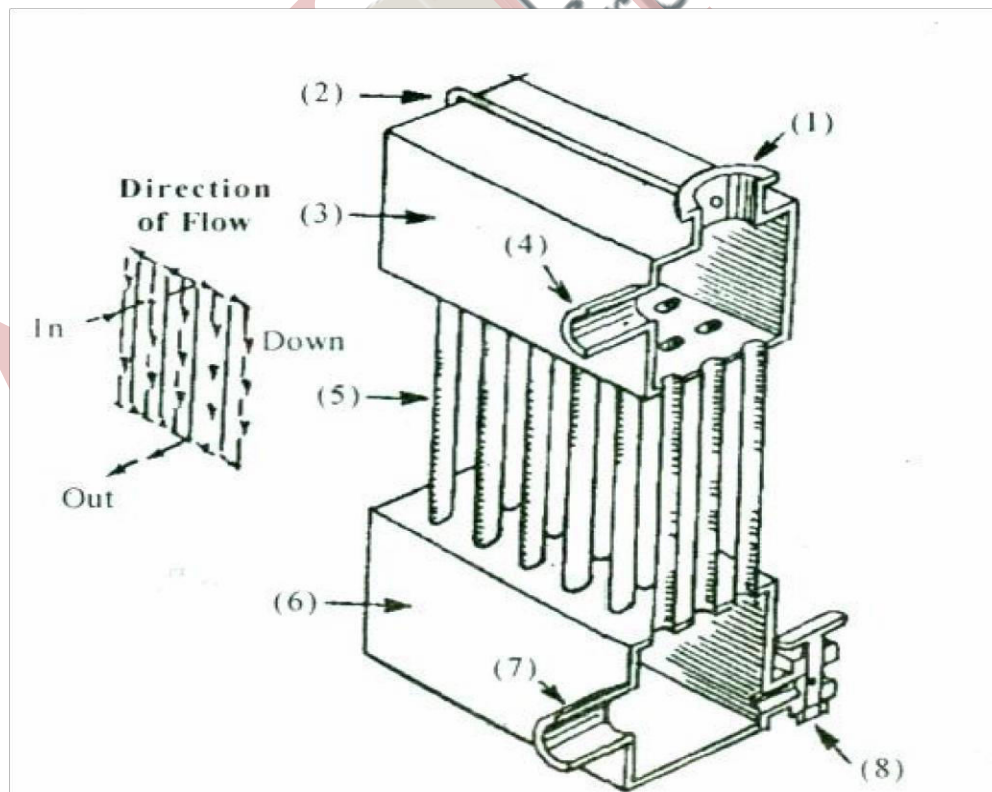


Fig (c): Typical radiator. Water enters the top hose connection - I, then passes into top tank 2. From there it flows down through core tubes 3. When it reaches bottom tank 4, it has cooled. 5 - Lower hose connections. 6 - Drain petcock.

**NEED FOR ENGINE COOLING**

The engine cooling is necessary due to following reasons.

1. As engine temperature increases, the strength of materials used for various engine components decreases. As an example, in water cooled engines the temperature of cylinder head should not exceed  $270^{\circ}\text{C}$ , and for air cooled engines, uses light alloys, the temperature should not exceed  $200^{\circ}\text{C}$ .
2. The lubricating oil used in the engine also decides the maximum temperature that can be used. For different lubricating oils, this temperature range varies from  $1600^{\circ}\text{C}$  to  $200^{\circ}\text{C}$ . If the engine temperature exceeds this limit, it may deteriorates the lubricating oil or evaporate and burn to cause piston and cylinder damage. Over heating results in piston seizing also.
3. High cylinder head temperature result in loss of volumetric efficiency and reduces power output.
4. High engine temperature may cause pre ignition and detonation.

## METHODS OF COOLING

1. Air cooling
2. Water cooling

1) **Air Cooling:** Here, the air stream flows continuously over the heated metal surface and the rate of heat dissipation depends on surface area of metal, air mass flow rate, thermal conductivity of metal, temperature difference between metal surface and air.

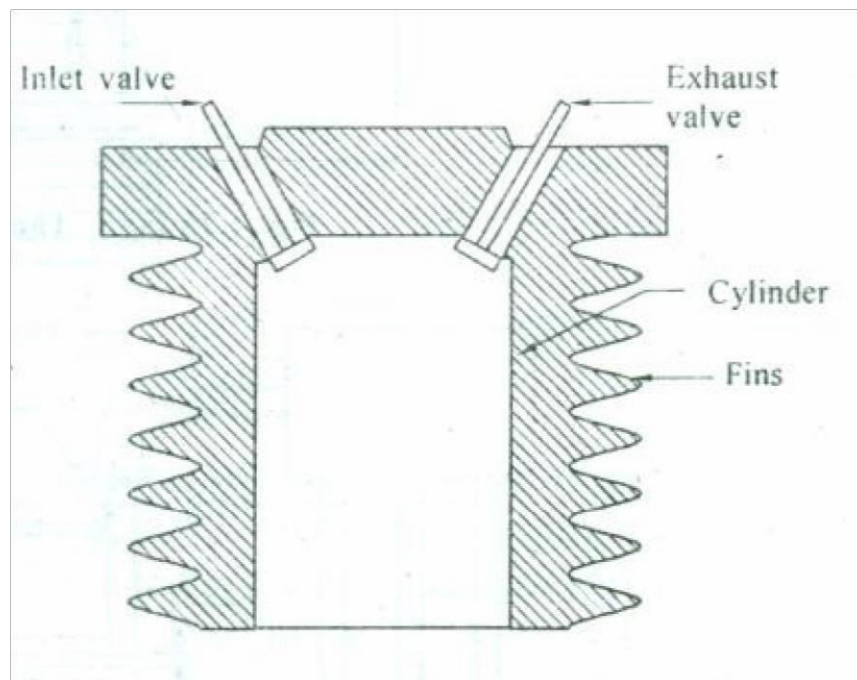
To increase the effectiveness, the metal surface area which is in contact with air should be increased. This is done by providing fins over cylinder barrels. The fins may be cast integral with the cylinder or may be attached separately.

### Advantages:

1. Absence of radiator cooling jackets and coolant reduces weight of the system.
2. Air cooled engines are useful in extreme climates, where water may freeze.
3. These engines warm up earlier than water cooled engines.
4. Easy maintenance as there is no leakage problem.

### Disadvantages:

1. These are noisier, because of absence of cooling water which acts as sound insulator.
2. Heat transfer co-efficient for air is less. Hence less efficient cooling and results in decrease of highest useful compression ratio.
3. Distortion of cylinder may occur due to uneven cooling all around the cylinder.



**Fig. Cylinder with Fins**

2) **Water Cooling:** In these systems, the water jackets surrounds engine cylinders and cooling water flows through these jackets. Heat is conducted through the cylinder walls to the water in the jackets which removes the excess heat as it circulates through the radiator.

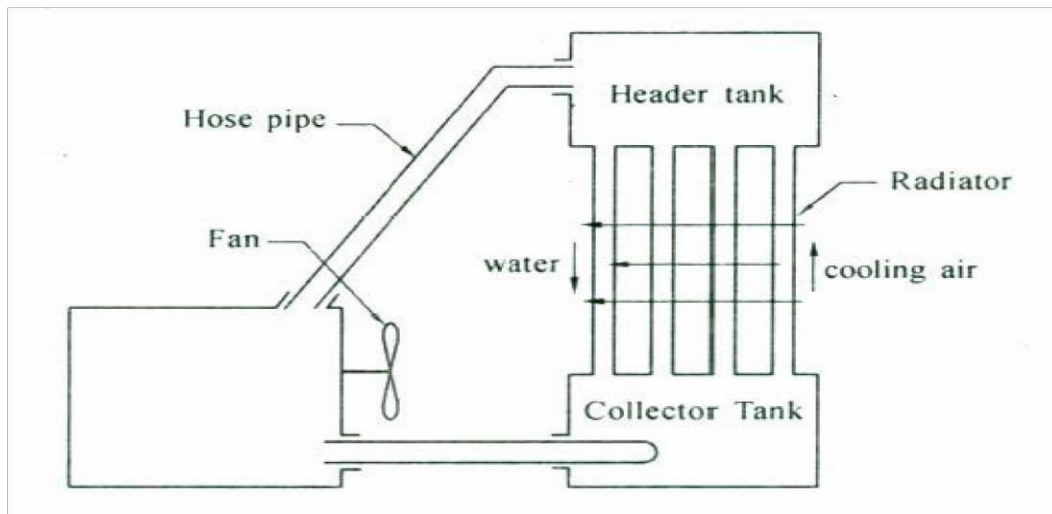
Water cooling systems are classified into two types.

- a. Thermosyphon system.
- b. Pump circulation system .

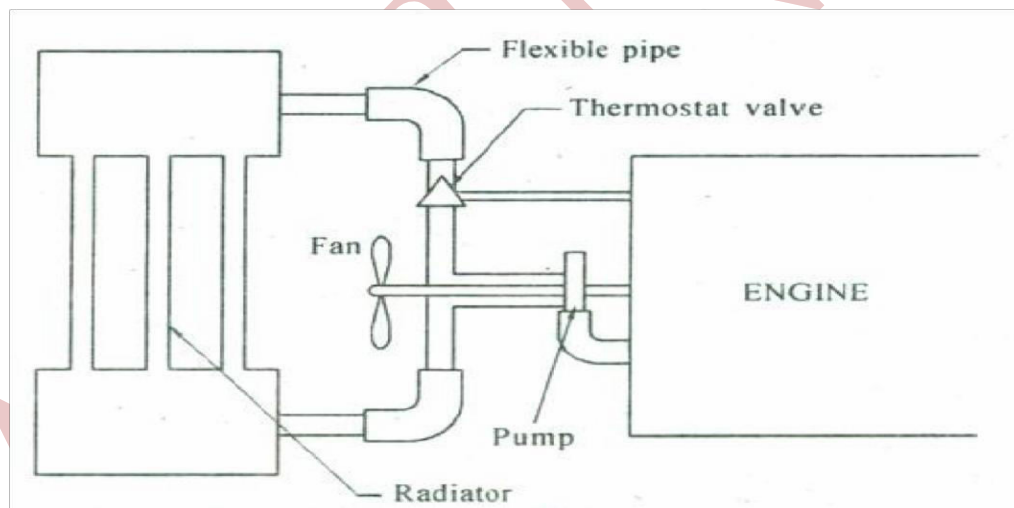
(a) **Thermosyphon system:** In this system the engine is connected to radiator through flexible hoses. The difference in densities of hot and cold regions of cooling water causes water circulation between engine and radiator. The water in circulation absorbs heat from engine cylinder and hence cool it. The heat from the water is then dissipated into atmosphere through the radiator by conduction and convection. This cools the water which is required for further circulation. Sometimes fans are used behind the radiator to increase the air mass flow rate and- hence to increase cooling efficiency.

(b) **Pump circulation system:** This system is similar to thermosyphon system explained above.

The only difference is cooling water circulation is affected by means of a pump and a thermostat valve controls the temperature of water.



**Fig (a): Thermosyphon Cooling System**



**Fig (b): Pump Circulation System**

**Advantages of this system over Thermosyphon system are:**

- (a) No need to place the radiator header tank above the engine level, as water circulation is effected by pump.
- (b) Radiator may be placed on the side or on the rear, if necessary.
- (c) Cooling water circulation is proportional to both load and speed.
- (d) Because of efficient cooling, water jacket size can be reduced. This results in overall decrease in engine size.



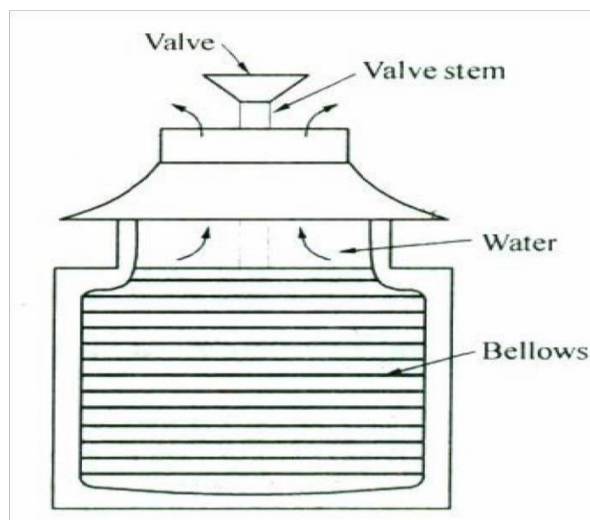
## THERMOSTAT VALVES

It is to be noted that the cooling beyond optimum limits is not desirable as it decreases the overall efficiency of the engine. A thermostat is used to regulate the rate of cooling. It keeps the cooling water temperature at a predetermined value.

Two types of thermostats are used in automobiles.

1. Bellows or aueroid type
2. Wax or hydrostatic type

### Bellows type thermostat:



**Fig. Bellows type thermostats**

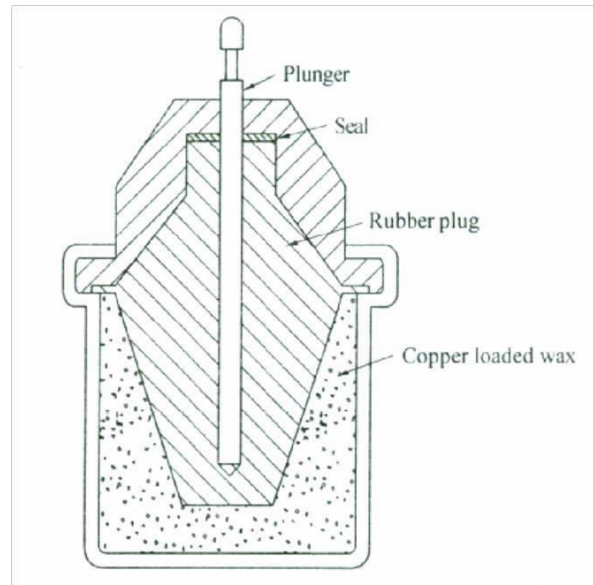
This thermostat consists of metallic bellows filled with some volatile liquids like alcohol, acetone, ether etc., whose boiling temperature ranges between 70-85°C. One end of bellows contains a valve and to the other end a frame is attached which fits in to the cooling passage. The thermostat is fitted in the water hose pipe at the engine outlet. After the engine has started, cooling system should not operate during warming up duration~ that engine warms up early. During this warming up period, the liquid inside the bellows has not yet changed its state and hence does not exert any pressure on the valve. Therefore the valve remains in closed position.

If the temperature of the cooling water exceeds a pre-determined as 80°C the liquid inside the bellows. Vaporizes and exerts a pressure on the valve. The valve opens and allows water circulation through the radiator, As water temperature rises, valve opens gradually, thus controls the flow of water through the radiator according to engine cooling requirement.

### Wax thermostat:

It is also known as Dole thermostat. This thermostat is more reliable to operate within the specified temperature range and is not sensitive to pressure variations. The heat carried by the coolant is transmitted to the copper loaded wax having high thermal expansion coefficient. The expansion of copper loaded wax makes the rubber plug to contract against the plunger and hence

exerts a force on it in upward direction. This makes the plunger to move upward and opens a valve in the thermostat (Not shown). This allows the coolant to flow through the radiator.



**Fig: Wax thermostat**

## ENGINE LUBRICATION

Lubrication is the most important phase of vehicle maintenance. Without lubrication, engine cannot run smoothly even a few minutes. Inadequate lubrication results in engine troubles like scored cylinders, burned out bearings, misfiring cylinders, dirty spark plugs, stuck piston rings, engine deposits and sludge and more fuel consumption.

Dry or solid friction is a result of direct contact between two metallic surfaces or due to interlocking of irregularities on metal surfaces, produces lot of heat and causes wear of the metal surface.

Hydrodynamic lubrication means, introduction of lubricating oil between two surfaces. There is no physical contact between them and only resistance to motion is resistance offered by the oil itself.

In boundary lubrication, the introduction of lubricant between surfaces will not cause complete separation between them. The surfaces touch at their high spots. Boundary lubrication exist in piston rings and valve train.

## OBJECTS OF LUBRICATION

The main objects of lubrication are

- (a) It reduces power loss by minimizing friction between moving parts.
- (b) Decreases wear and tear of the moving components.

The lubrication also serves other purposes like.

1. **Cooling effect:** The lubricant absorbs heat from hot moving parts and dissipates it to the

surrounding air through the crank case.

2. **Cushioning effect:** The lubricant serves as a good cushion against shocks present in the engine. For example, instant combustion causes sudden pressure rise and the resultant shock goes to the bearings through piston, piston pin and connecting rod. Then the lubricant present in the main bearings absorbs this shock.
3. **To act as cleaning agent:** As lubricating oil circulates, it absorbs so many impurities and oil may be further purified by filtration. Ex.: oil dissolves carbon particles during its circulation.
4. **Sealing action:** It maintains an effective seal on the piston rings and avoids entry of high pressure gases into the crank case.

## ENGINE LUBRICATION SYSTEMS

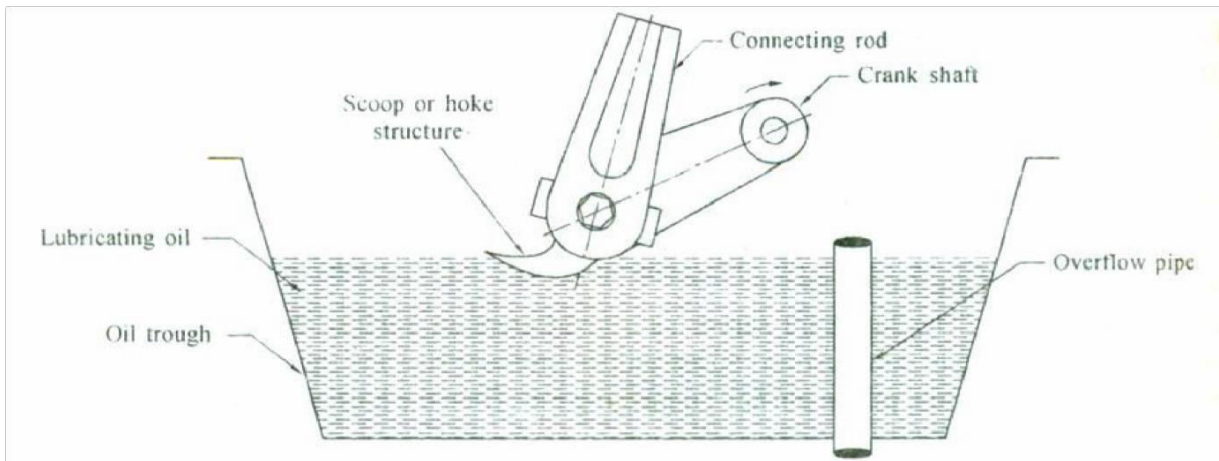
In an automobile engine, various systems adopted for lubrication are classified in to

1. Petrol-oil system (Mist lubrication).
2. Wet sump system.
  - (a) Splash lubrication
  - b) Pressure feed lubrication
3. Dry sump system

1. **Petro-oil System:** In this method some amount of lubricating oil is directly mixed with the petrol. i.e., about 25 to 30ml. of oil mixes with one litre of petrol. If oil is less, it causes damage to the engine. If addition of oil is more, there may be excessive carbon deposits in the cylinder head and produces poor emissions. This method is used in scooter and motor cycles [two-stroke engines].
2. **Wet Sump System:** In this system, the crank case contains an oil pan or sump that serves as the oil supply or reservoir tank. It also serves as the oil cooler. Oil from the cylinders and bearings flows by gravity back into the wet sump from where it is pumped and recirculated to the engine lubricating system. The wet sump system is again classified into
  - a) Splash lubrication system.
  - b) Pressure feed system.
  - b) Semi pressure feed system.

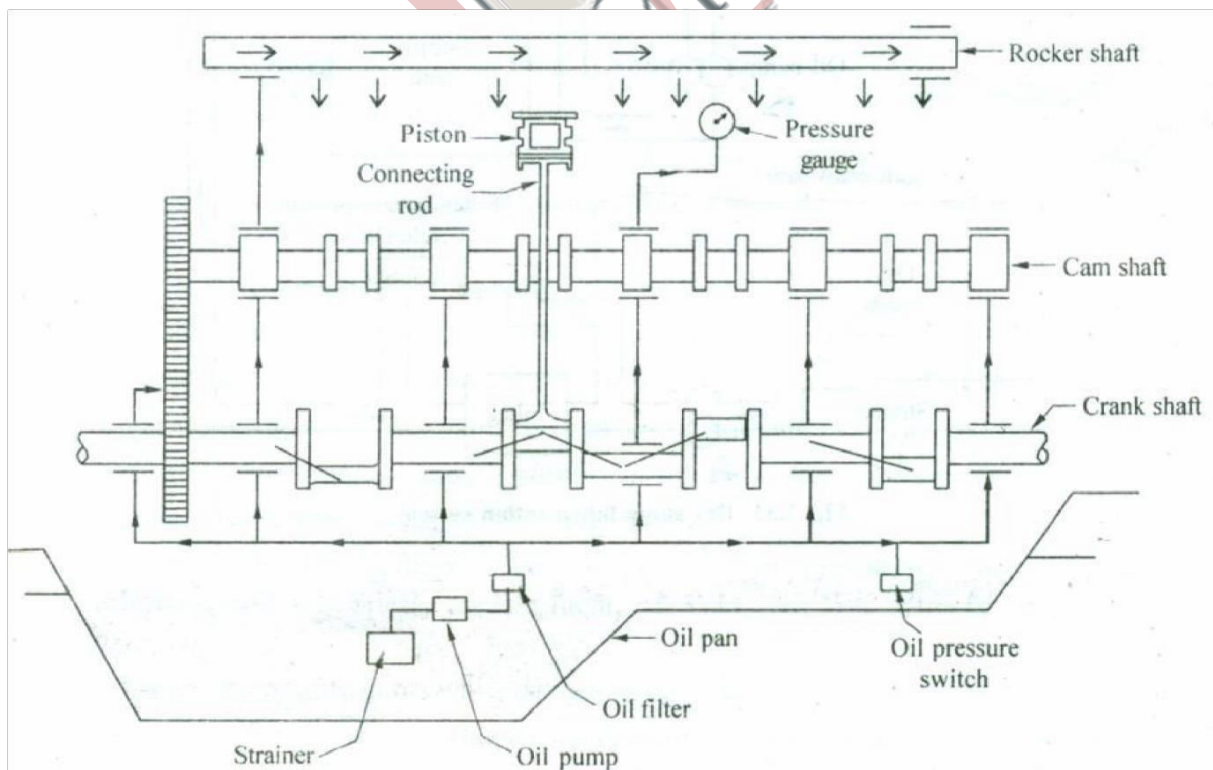
**(a) Splash Lubrication System:** It is the cheapest method of lubrication and was used in early motor cycles. The lower end of the connecting rod consists of a scoop like structure as in the figure. The oil is stored in the oil trough (being delivered from the crank case oil sump).

When the engine runs, the connecting rod oscillates and the scoop takes the oil from oil trough and splashes on to the cylinder walls each time when it passes through BDC position. This lubricates engine walls, gudgeon pin, main crank shaft bearings, big end bearings etc. The oil dripping from the cylinder walls, collects in the tank where it is cooled by air flow.



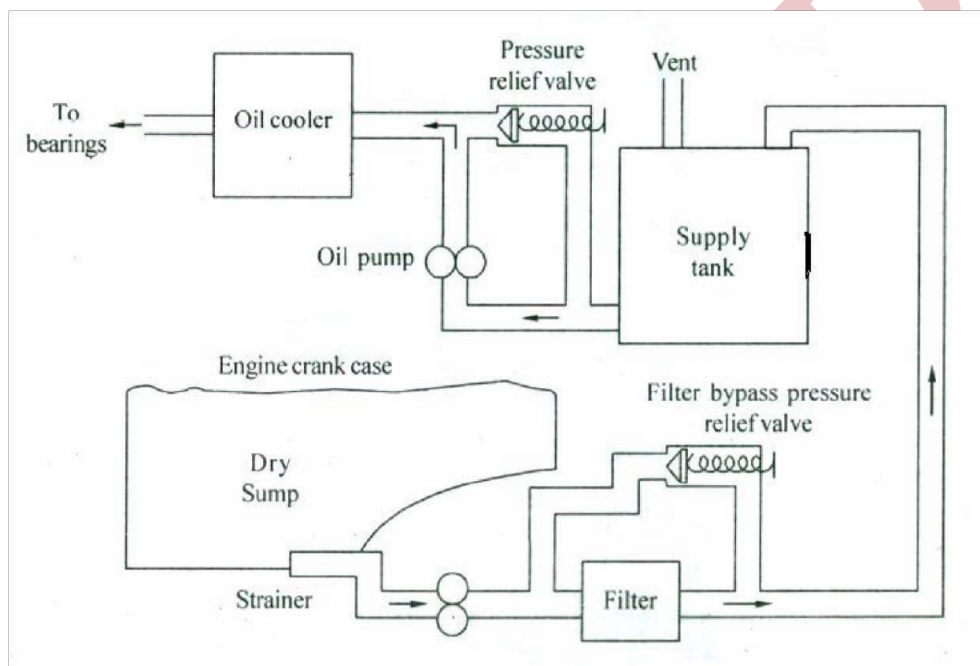
**Fig: Splash lubrication system**

**(b) Pressure Feed System:** This system is most commonly used in modern car engines. In this system, the oil forces oil under pressure to the main bearings, connecting rod and cam shaft bearings and also to the timing gears. Drilled assuages in the crank shaft carry oil from the main bearings to the connecting rod bearings. The cylinder walls, piston pin, piston and piston rings are lubricated by oil spray from the connecting rod and crank shaft. For the cam shaft and timing gears, there is a separate oil line from the main oil gallery. The basic components of the wet lubricating system are pump, strainer, pressure regulator, filter etc.



**Fig: Full pressure feed lubrication system**

**3. Dry Sump Lubricating System:** In this system, two pumps are used. The pump 'A' is called scavenging pump and is located in the crank case portion as in figure. The oil from this pump is carried to an external tank i.e., reservoir. The pressure pump 'B' pumps the oil through filter to the cylinder and bearings. Oil dripping from cylinder and bearings into the sump is again removed by scavenging pump (sump pump), which supplies oil to the reservoir. As the capacity of sump pump is greater than oil pump, oil will not be accumulated in the engine base. The oil pump draws oil from the supply tank and delivers it under pressure to the engine bearings and oil pressure of 400-500 kpa is maintained in main and big end bearings. A pressure of about 50-100 kpa is maintained in timing gears and cam shaft bearings etc. This system is suitable for lubricating sport cars, jeeps etc.

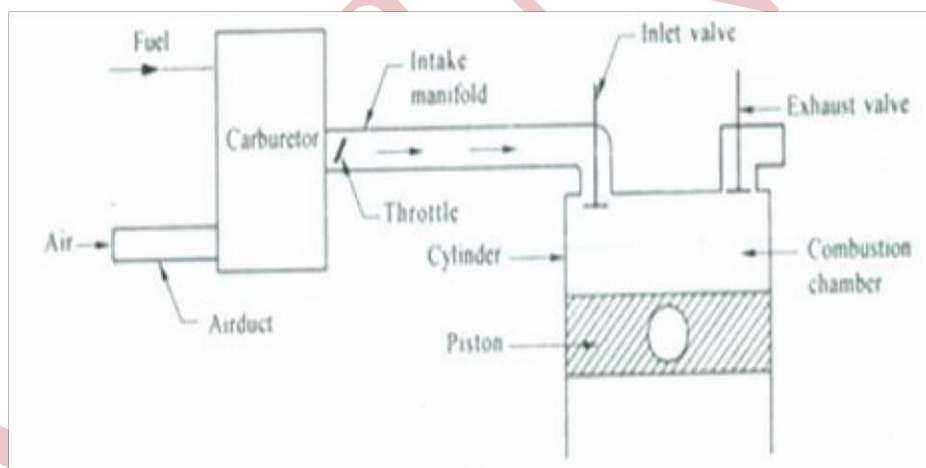


**Fig. Dry sump lubrication system**

## UNIT – 2

**FUEL SUPPLY SYSTEMS FOR SI AND CI ENGINES****INTRODUCTION**

In an engine, the combustion of fuel with oxygen in the combustion chamber provides the energy necessary to drive the piston. In a SI engine, the liquid fuel and the air are generally mixed prior to their arrival in the combustion chamber i.e., outside the engine cylinder. The process of preparing this mixture is called carburetion. The basic fuel supply system in a petrol engine consists of a fuel tank, fuel lines, fuel pump, fuel filters, air cleaner, carburetor and inlet manifold. The system responsible for preparing the correct mixture of air and fuel, and directing this mixture to each of the cylinders is known as "Induction System". The Intake manifold is the ducting or piping through which the fuel and air mixture travels from the carburetor to the cylinder. The throttle in the carburetor regulates the quantity of mixture entering the cylinder. The carburetor is a device which atomizes the fuel and mixes it with air.



**Fig: Diagram of induction system**

**CONVENTIONAL FUELS:**

Traditional energy sources or fossil fuels (petroleum, oil, coal, propane, and natural gas). In some cases nuclear materials such as uranium are also included. Some conventional sources typically used are fossil fuels, nuclear power, hydropower, and geothermal energy.

**(a) Fossil Fuels**

Clean coal technologies imply much greater processing to reduce final emissions. The resources deplete with use, so the prices will increase when demand chases supply.

**(b) Hydropower**

The larger hydropower dams are in place. Some want them removed, claiming that the electricity can be offset by improved efficiency and conservation. Smaller dams are being removed, yet they may be

installed in other locations.

**(c) Nuclear**

Nuclear energy has a social problem, and only now are new plants being considered. Without reprocessing "spent fuel", the time to peak ore extraction is about 80 years.

**(d) Geothermal**

Geothermal energy is possible in non geyser areas where air conditioning and heating can make use of the ground heat flux.

**ALTERNATIVE FUELS:**

Alternative fuels, known as non-conventional or advanced fuels, are any materials or substances that can be used as fuels, other than conventional fuels. Conventional fuels include: fossil fuels (petroleum (oil), coal, and natural gas), as well as nuclear materials such as uranium and thorium, as well as artificial radioisotope fuels that are made in nuclear reactors. Some well known alternative fuels include biodiesel, bio alcohol (methanol, ethanol, butanol) chemically stored electricity (batteries and fuel cells), hydrogen, nonfossil methane, non fossil natural gas, vegetable oil, propane, and other biomass sources

**(a) Bio-fuel:** Bio-fuels are also considered a renewable source. Although renewable energy is used mostly to generate electricity, it is often assumed that some form of renewable energy or a percentage is used to create alternative fuels.

**(b) Biomass:** Biomass in the energy production industry is living and recently dead biological material which can be used as fuel or for industrial production.

**(c) Algae-based fuels:** Algae-based bio-fuels have been promoted in the media as a potential panacea to crude oil-based transportation problems. Algae could yield more than 2000 gallons of fuel per acre per year of production. Algae based fuels are being successfully tested by the U.S. Navy Algae-based plastics show potential to reduce waste and the cost per pound of algae plastic is expected to be cheaper than traditional plastic prices

**(d) Biodiesel:** Biodiesel is made from animal fats or vegetable oils, renewable resources that come from plants such as, jatropha, soybean, sunflowers, corn, olive, peanut, palm, coconut, safflower, canola, sesame, cottonseed, etc. Once these fats or oils are filtered from their hydrocarbons and then combined with alcohol like methanol, biodiesel is brought to life from this chemical reaction. These raw materials can either be mixed with pure diesel to make various proportions, or used alone. Despite one's mixture preference, biodiesel will release smaller number of pollutants (carbon monoxide particulates and hydrocarbons) than conventional diesel, because biodiesel burns both cleanly and more efficiently. Even with regular diesel's reduced quantity of sulfur from the ULSD (ultra-low sulfur diesel) invention, biodiesel exceeds those levels because it is sulfur-free

**(e) Alcohol fuels:** Methanol and ethanol fuel are primary sources of energy; they are convenient fuels for storing and transporting energy. These alcohols can be used in internal combustion engines as alternative fuels. Butanol has another advantage: it is the only alcohol-based motor fuel that can be transported readily by existing petroleum-product pipeline networks, instead of only by tanker trucks and railroad cars

**(f) Ammonia:** Ammonia (NH<sub>3</sub>) can be used as fuel. Benefits of ammonia include no need for oil, zero emissions, low cost, and distributed production reducing transport and related pollution

(g) **Carbon neutral fuel:** Carbon neutral fuel is synthetic fuel—such as methane, gasoline, diesel fuel or jet fuel produced from renewable or nuclear energy used to hydrogenate waste carbon dioxide recycled from power plant flue exhaust gas or derived from carbonic acid in seawater.

(h) **Hydrogen:** Hydrogen is an emission less fuel. The byproduct of hydrogen burning is water, although some mono-nitrogen oxides NO<sub>x</sub> are produced when hydrogen is burned with air.

(i) **Liquid nitrogen:** is another type of emission less fuel.

(j) **Compressed air :** The air engine is an emission-free piston engine using compressed air as fuel. Unlike hydrogen, compressed air is about one-tenth as expensive as fossil oil, making it an economically attractive alternative fuel.

(k) **CNG fuel:** CNG vehicles can use both renewable CNG and non-renewable CNG. Conventional CNG is produced from the many underground natural gas reserves are in widespread production worldwide today. New technologies such as horizontal drilling and hydraulic fracturing to economically access unconventional gas resources, appear to have increased the supply of natural gas in a fundamental way.

Renewable natural gas or biogas is a methane based gas with similar properties to natural gas that can be used as transportation fuel. Present sources of biogas are mainly landfills, sewage, and animal/agri waste. Based on the process type, biogas can be divided into the following: Biogas produced by anaerobic digestion, Landfill gas collected from landfills, treated to remove trace contaminants, and Synthetic Natural Gas (SNG)

(l) **HCNG:** HCNG (or H<sub>2</sub>CNG) is a mixture of compressed natural gas and 4-9 percent hydrogen by energy.

#### **NORMAL COMBUSTION & ABNORMAL COMBUSTION NORMAL COMBUSTION:**

Under ideal conditions the common internal combustion engine burns the fuel/air mixture in the cylinder in an orderly and controlled fashion. The combustion is started by the spark plug some 10 to 40 crankshaft degrees prior to top dead center (TDC), depending on many factors including engine speed and load. This ignition advance allows time for the combustion process to develop peak pressure at the ideal time for maximum recovery of work from the expanding gases.

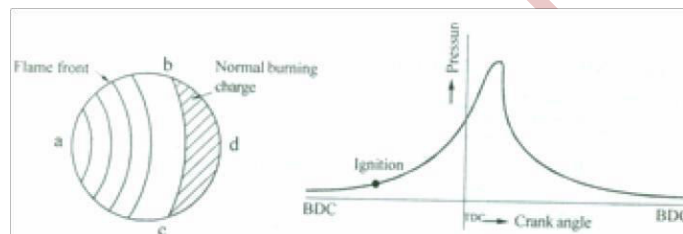
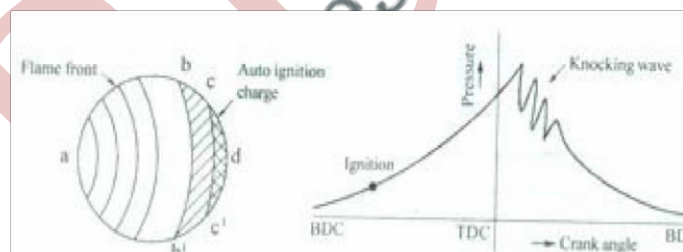
The spark across the spark plug electrodes forms a small kernel of flame approximately the size of the spark plug gap. As it grows in size, its heat output increases, which allows it to grow at an accelerating rate, expanding rapidly through the combustion chamber. This growth is due to the travel of the flame front through the combustible fuel air mix itself, and due to turbulence which rapidly stretches the burning zone into a complex of fingers of burning gas that have a much greater surface area than a simple spherical ball of flame would have. In normal combustion, this flame front moves throughout the fuel/air mixture at a rate characteristic for the particular mixture. Pressure rises smoothly to a peak, as nearly all the available fuel is consumed, then pressure falls as the piston descends. Maximum cylinder pressure is achieved a few crankshaft degrees after the piston passes TDC, so that the force applied on the piston (from the increasing pressure applied to the top surface of the piston) can give its hardest push precisely when the piston's speed and mechanical advantage on the crank shaft gives the best recovery of force from the expanding gases, thus maximizing torque transferred to the crank shaft.



**ABNORMAL COMBUSTION:**

When unburned fuel/air mixture beyond the boundary of the flame front is subjected to a combination of heat and pressure for certain duration (beyond the delay period of the fuel used), detonation may occur. Detonation is characterized by an instantaneous, explosive ignition of at least one pocket of fuel/air mixture outside of the flame front. A local shockwave is created around each pocket and the cylinder pressure may rise sharply beyond its design limits.

If detonation is allowed to persist under extreme conditions or over many engine cycles, engine parts can be damaged or destroyed. The simplest deleterious effects are typically particle wear caused by moderate knocking, which may further ensue through the engine's oil system and cause wear on other parts before being trapped by the oil filter. Severe knocking can lead to catastrophic failure in the form of physical holes punched through the piston or cylinder head (i.e., rupture of the combustion chamber), either of which depressurizes the affected cylinder and introduces large metal fragments, fuel, and combustion products into the oil system. Hypereutectic pistons are known to break easily from such shock waves.

**Fig: Normal combustion****Fig: Combustion with Detonation**

Detonation can be prevented by any or all of the following techniques:

- The use of a fuel with high octane rating, which increases the combustion temperature of the fuel and reduces the proclivity to detonate;
- Enriching the air–fuel ratio which alters the chemical reactions during combustion, reduces the combustion temperature and increases the margin above detonation;
- Reducing peak cylinder pressure;
- Decreasing the manifold pressure by reducing the throttle opening, boost pressure or reducing the load on the engine.

## CETANE AND OCTANE NUMBERS

**Cetane numbers:** In diesel engines cetane number is a measure of ignition lag. Cetane is straight chain paraffin assigned with a rating of 100 cetane numbers (CN) and it has good ignition quality. It is mixed with alpha-methylnaphthalene a hydrocarbon with poor ignition quality i.e., with zero cetane number. A CFR engine running under prescribed conditions test the fuel with this mixture. Thus the cetane number of the fuel is defined as the percent by volume of cetane in a mixture of cetane and alpha-methyl that produces same ignition lag as the fuel being tested, in the same engine and under the same operating conditions.

For a diesel fuel, cetane rating is a measure of its ability to auto ignite readily when it is injected in to the compressed air in the engine. The ignition delay is influenced by several engine design parameters such as compression ratio, injection rate, injection time inlet air temperature etc. The hydrocarbon composition of the fuel and its volatility characteristics also affects the ignition delay. The cetane rating of diesel fuels ranges from 40 to 60. The octane fuels (gasoline) have cetane numbers ranging from 10 to 20 showing their poor suitability as a diesel fuel. High cetane number results in pre-ignition in diesel engine.

**Octane numbers:** The composition of fuel affects detonation. In SI engines, for a particular fuel, the rating is done by comparing its performance with that of a standard reference fuel which is a combination of ISO octane and n-heptane. ISO octane offers great resistance to detonations and is assigned a rating of 100 octane number. On the other hand, n-heptane is a straight chain paraffin and is assigned with a rating of '0' octane number. The percentage of ISO-octane by volume in a mixture of ISO octane and n-heptane, which exactly matches the knocking intensity of a given fuel, in a standard engine under prescribed operating conditions is termed as "octane number" of the fuel. If octane number of a fuel is 80, it means that it has a same knocking tendency of a mixture with 80% ISO octane and 20% n-heptane by volume. The engine used to conduct test is CFR (operative fuel research) variable compression ratio engine. The fuel is to be tested in the CFR engine until the condition of detonation is reached in the engine. Then a mixture of ISO-octane and n-heptane is prepared to produce detonation under the same conditions as the fuel under test. The percentage by volume of ISO-octane in the mixture is nothing but the octane number of the fuel.

## MIXTURE REQUIREMENTS FOR SI ENGINE

In stationary engines the desired air fuel ratio means that gives the maximum economy. Actual air fuel mixture requirements in an operating engine vary under variable speed and load conditions. The A/F ratios must change based on maximum power is required. Also required A/F ratio must be provided for transient conditions like, starting a warm-up and acceleration. In all these conditions, exhaust emission should be minimum.

In steady state operation (It means continuous operation at a given speed and over out with normal engine temperature) of automotive engines, there are three main areas which require different air-fuel ratios. In each of these, the engine requirements differ. As a result the carburetor has to modify A/F. ratio to satisfy these demands. These ranges are

1. Idling (mixture must be enriched)

2. Cruising (mixture must be leaned)
3. High Power (mixture must be enriched)

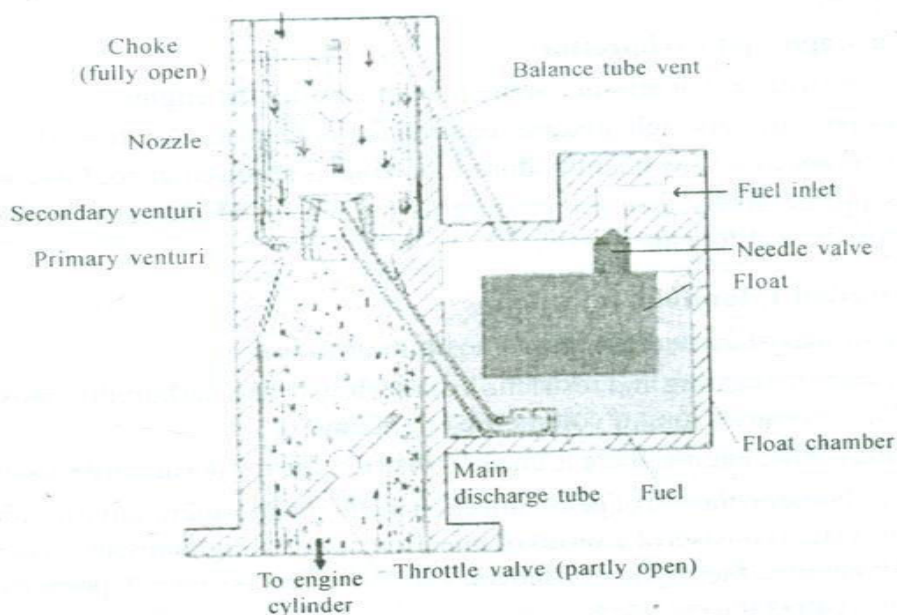
### Carburetor:

A carburetor is a device that blends air and fuel for an internal combustion engine. The carburetor works on Bernoulli's principle: the faster air moves, the lower its static pressure, and the higher its dynamic pressure. The throttle (accelerator) linkage does not directly control the flow of liquid fuel. Instead, it actuates carburetor mechanisms which meter the flow of air being pulled into the engine. The speed of this flow, and therefore its pressure, determines the amount of fuel drawn into the airstream.

When carburetors are used in aircraft with piston engines, special designs and features are needed to prevent fuel starvation during inverted flight. Later engines used an early form of fuel injection known as a pressure carburetor

Under all engine operating conditions, the carburetor must:

- Measure the airflow of the engine
- Deliver the correct amount of fuel to keep the fuel/air mixture in the proper range (adjusting for factors such as temperature)
- Mix the two finely and evenly



**Fig: Simple Carburetor**

A carburetor basically consists of an open pipe through which the air passes into the inlet manifold of the engine. The pipe is in the form of a Venturi it narrows in section and then widens again, causing the airflow to increase in speed in the narrowest part. Below the Venturi is a butterfly valve called the throttle valve a rotating disc that can be turned end-on to the airflow, so as to hardly

restrict the flow at all, or can be rotated so that it (almost) completely blocks the flow of air. This valve controls the flow of air through the carburetor throat and thus the quantity of air/fuel mixture the system will deliver, thereby regulating engine power and speed. The throttle is connected, usually through a cable or a mechanical linkage of rods and joints or rarely by pneumatic link, to the accelerator pedal on a car or the equivalent control on other vehicles or equipment.

Fuel is introduced into the air stream through small holes at the narrowest part of the Venturi and at other places where pressure will be lowered when not running on full throttle. Fuel flow is adjusted by means of precisely calibrated orifices, referred to as jets, in the fuel path.

## CARBURETOR TYPES

Carburetors used in SI engines are classified into up draft, down draft and horizontal (side) draft types, according to the direction in which the air and fuel mixture is supplied by them. In down draft type, gravity assists the flow of mixture and hence engine pulls better at lower speeds under load. Carburetors are also classified as constant choke carburetor and constant draft or vacuum carburetor. In constant choke type the air and fuel flow areas are always maintained constant and depression (pressure difference) which causes fuel flow is being varied according to engine condition. Ex.: Simple, Solex, Zenith and Carter carburetors. In constant vacuum type, the air and fuel flow areas are being varied as per demand on the engine while depression or vacuum is always maintained constant. It is also called as variable choke carburetor. Ex.: S.U. type carburetor.

### (a) Solex Carburetor

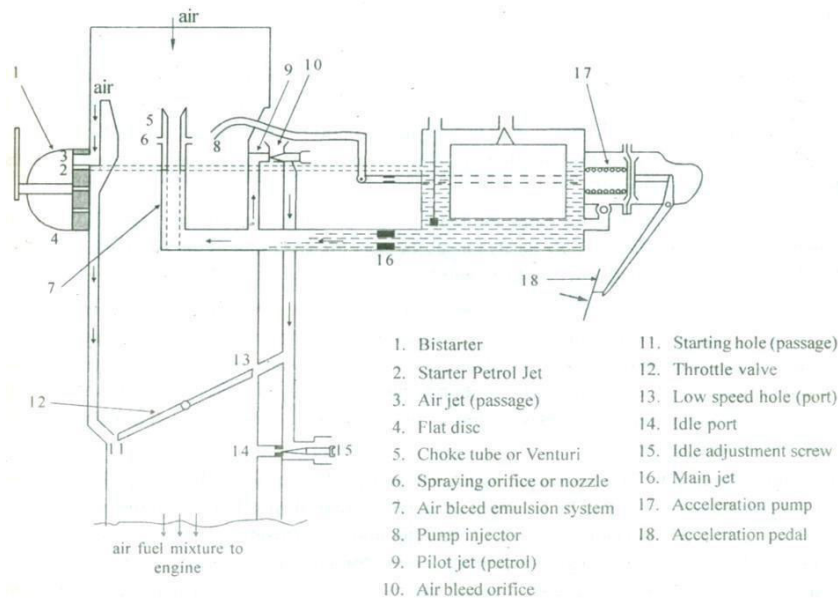
The Solex carburetor is a down draft type and have been manufactured in India by Mis. Carburetor Limited, Madras. It is famous for ease of starting, good performance and reliability. It is available in various models and used in Fiat and Standard Cars and Willis Jeep. The unique feature of this carburetor is the Bi-Starter for cold starting.

The various circuits are explained as follows:

**1.Normal Running:** The carburetor has a conventional float in a float chamber. For normal running, throttle is held partly open and fuel is supplied by the main jet and air by the choke tube or venturi. The air directly enters through the venturi and fuel passes into the well of air bleed emulsion system. It is a tube having lateral holes and nozzles are drilled horizontally in the middle as shown in figure. This system provides metered emulsion of fuel and air through the nozzles for the normal working of the engine.

**2.Cold Starting and Warming:** This carburetor has provision of Bi-starter or progressive starter. The starter valve is a flat disc having holes of different sizes. These holes connect starter petrol jet and starter air jet to the passage which opens just below the throttle valve. The starter lever position can be adjusted on the dash board and this connects air and petrol jet to the passage through holes of different sizes. Rich mixture is used for starting and after the engine has started, richness required decreases. This means bigger holes are the connecting holes for starting and throttle valve is in the closed position. The whole engine suction is acted at starting passage. This suction effect draws fuel from float chamber and the fuel passes through starter petrol jet and mixes with air entering through the air jet. This mixture is rich enough for starting.

The starter lever is to be brought to intermediate position after starting the engine. This connects the smaller holes into the circuit and this reduces the amount of petrol. In this condition the main jet also delivers fuel as the throttle valve is partly opened. The starter system delivers less mixture but it is sufficient to keep the engine in running condition, till it reaches normal running temperature.



**Fig: Solex Carburetor**

**3. Idling or Slow Speed Operation:** An idle port controlled by idle adjusting screw is provided in the engine side of throttle valve. The emulsion system well is connected to Pilot Jet through a hole. At idling as throttle is almost closed, the engine suction is applied at the Pilot Petrol Jet, which supplies petrol drawn from main jet circuit. The air is drawn in from the pilot air jet. The petrol and air mix in the idle passage and mixture comes out of the idle port.

To avoid flat spot and to ensure smooth transfer from idle and low speed circuit to the main jet circuit, slow running openings are provided on the venturi side of the throttle valve. As throttle is widely opened, the suction at idle port is decreased. But now suction is applied at the slow speed openings, which more than offsets the loss of suction at the idle port and thus flat spot is avoided.

**4. Acceleration:** This consists of a diaphragm type acceleration pump. It delivers spurts of extra fuel needed for the acceleration through pump injector. Pump lever is connected to the accelerator pedal so that when the pedal is pressed, lever moves towards left, thus pressing the membrane to the left. This forces petrol into main jet circuit through pump jet and injector. When the pedal is left free, the lever moves the diaphragm back towards right creating vacuum to the left. This opens the pump inlet valve and thus admits petrol from float chamber into the pump.

**(b) Zenith Carburetor**

This type is most commonly used in petrol engines. The figure shows simple view of a zenith carburetor which contains float control, compensating jet and accelerating device.

**1. Float Control:** The arrangement for the fuel level control is as shown in figure. The two balls 'A'

& 'B' are resting on a conventional float. As engine speed increases, fuel consumption will be more and fuel level in the float chamber decreases. As a result, the float and balls 'A' & 'B' comes down and force  $2F$  acts on the collar in upward direction. This force lifts the spindle up and provides more opening for the fuel flow into float chamber. This increases fuel level and thus the level is maintained constant. If fuel level increases, the float and balls 'A' & 'B' moves up causing force  $2F$  to act in the down ward direction. The spindle partly closes the opening and reduces the fuel flow. Thus the fuel level is maintained constant in the float chamber.

**2 Starting Jet:** During starting, the compensatory well is completely filled with fuel. The throttle valve is slightly open and whole of engine suction acts near the throttle valve at point 'C'. This suction causes flow of fuel from compensating well through starting jet line. Due to high suction, enough quantity of fuel is supplied and thus a rich mixture is supplied to the engine. For higher speeds the throttle valve is opened wide and suction at point 'C' is destroyed, thus stops flow of fuel from the starting jet line.

**3 Compensating Jet:** The compensating jet or double jet delivers lean mixture and this compensates for the rich mixture supplied by the main jet under increased speed of the engine and overall NF ratio is maintained constant. The area of main jet and compensating jet is equivalent to a single main jet which is designed to give required NF ratio for a particular speed. As fuel flow from float chamber to the compensating well through the restricted orifice is less than that of through the compensating jet, the fuel level in it decreases with increasing engine speed. The atmospheric air is passed into the compensating well as it is open to atmosphere and less fuel is supplied with increase in speed. The main jet provides richer mixture and compensating jet provides leaner mixture with increase in engine speed and thus AIF ratio is maintained constant.

**4 Acceleration:** In zenith carburetor, no separate device is used for acceleration. Sudden acceleration of the engine is not possible when throttle is fully open at higher speeds, because the compensating well is normally dry. It is full of fuel only during idling or slow running and supplies fuel required for sudden acceleration. So as soon as the throttle is open, the sudden depression due to inflow of the air near the venturi draws in whole fuel from compensating well through compensating jet and provides rich mixture for acceleration, thus only momentarily acceleration is possible.

**5 Choking:** A manually operated choke valve is used for starting the engine from cold weather conditions.

### (c) S.U. Carburetor

S.U. Carburetor is a constant vacuum or depression type with automatically variable choke or venturi. The mixture compensation is achieved by maintaining constant vacuum over the jet and varying the effective size of the jet. A S.U. Carburetor of horizontal type is as shown in figure. No separate idling or acceleration device is used here.

A spring loaded piston controls the air passage (Venturi) which is in the form of rectangular opening of constant width and adjustable height. A slot is made in the piston which connects upper side of suction disc and throttle passage. The lower side is exposed to atmospheric pressure. Thus the position of piston at any instant depends upon the balance of it's own weight (down) against the vacuum force (up). As piston weight is constant, vacuum also remain constant. A Tapering needle is fixed to the piston. The piston movement varies the air passage and hence size of the petrol jet. The

lower end of the needle is inside the main jet and the needle moves up and down as the piston moves up and down. This changes annular area for the fuel flow. When the needle moves up area increases and vice versa.

A damper plunger is used to regulate the rate of lift of the piston, but allows the same to fall freely when throttle valve is closed. For acceleration, if the throttle valve is opened suddenly, the piston lifting speed is retarded by the damper plunger and provides additional depression over the fuel jet. This causes flow of more fuel and hence no separate acceleration pump is required.

Jet adjusting nut is used to adjust mixture strength. Tightening the nut will raise the jet and this reduces the annular area for fuel flow. Similarly-loosening the nut lowers the jet and thus increases fuel supply.

The unique feature of S.U. Carburetor is that it has only one jet. A constant high air velocity across the jet is maintained even under idling condition and the necessity for a separate idling jet is obviated. -

For cold starting a rich mixture is required. This is done by lowering the jet tube away from the needle by means of the jet lever, thereby enlarging the jet orifice. The lever is operated from the dash board in the car.

**(d) Carter Carburetor:** This carburetor is an American make and used in jeep. It is a down draft type and has three venturi (triple venturi diffusing type of choke). The small venturi is kept above the float chamber level, other two below the petrol level, one below other.

The carburetor consists of following circuits.

1. Float Chamber Circuit.
2. Starting Circuit.
3. Idle and Low Speed Circuit.
4. Part and Full Throttle Circuit
5. Acceleration Circuit.

1. **Float Chamber Circuit:** It consists of a conventional float and a float chamber. Fuel enters the float chamber from main supply. A needle valve maintains fuel level in the float chamber. When the fuel level falls, the needle valve opens the inlet to admit more fuel. Air enters the carburetor from the top. The choke valve in the passage remains open during normal running.

2. **Starting Circuit:** For starting a choke valve is provided in the air circuit. It is mounted eccentrically. When the engine is fully choked (choke valve is closed), whole of engine suction is applied at the main nozzle, which then delivers fuel. As the air flow is quite small, the mixture supplied is very rich. Once the engine starts, the spring controlled choke valve opens to provide correct amount of air during warming up period. '

3. **Idle and Low Speed Circuits:** In this carburetor separate idling passage is provided with low speed port and idle port. For Idling rich mixture is required in small quantity and throttle valve is almost closed. The full engine suction is now applied at the idle port through which the air and

fuel are drawn thus provides rich mixture. In low speed operation the throttle valve is opened further. The main nozzle also starts supplying the fuel. In this stage fuel is delivered both by main venturi and low speed port through idle passage.

4. **Part and Full Throttle Circuit:** In part throttling, fuel is delivered by the main nozzle only. During full throttling, maximum air is passing through the venturi. To compensate this higher rate of fuel flow is desired. This is obtained by mechanical metering method which uses a metering rod having a number of steps of diameter sizes at its bottom. It is connected with the accelerator pedal through Linkage. The area of opening between the metering rod jet and metering rod governs the amount of fuel drawn into the engine. When the accelerator pedal is pressed, the throttle is held wide open and simultaneously the metering rod is lifted up. In this condition, the smallest diameter of the rod is inside the fuel hole (jet), providing larger flow area, thus delivering more fuel.
5. **Acceleration Circuit:** The accelerating pump will not provide continuous fuel supply for acceleration but only provides extra spurt of fuel to avoid flat spot [popping of engine]. When accelerator pedal is pressed, pump actuates giving an extra spurt of fuel for acceleration. When the pedal is released the pump piston moves up there by sucking fuel from float chamber for next operation.

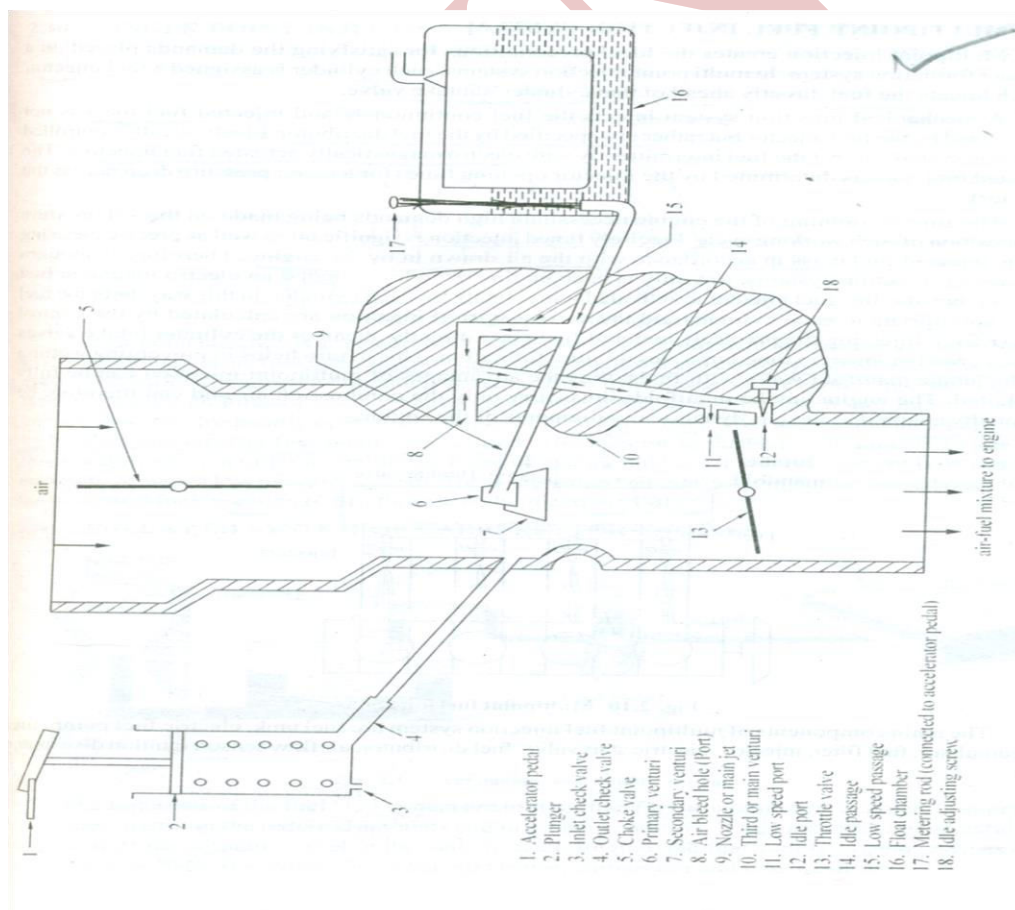


Fig. Carter Carburetor

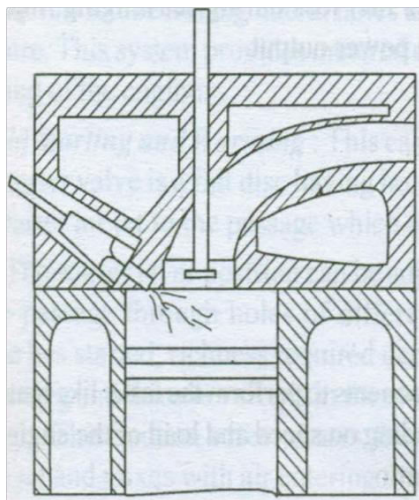


## Fuel injection

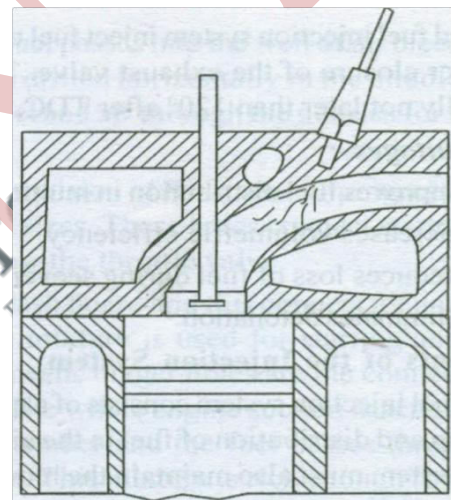
Fuel injection is a system for admitting fuel into an internal combustion engine. It has become the primary fuel delivery system used in automotive engines, having replaced carburetors during the 1980s and 1990s. A variety of injection systems have existed since the earliest usage of the internal combustion engine. The primary difference between carburetors and fuel injection is that fuel injection atomizes the fuel by forcibly pumping it through a small nozzle under high pressure, while a carburetor relies on suction created by intake air accelerated through a Venturi-tube to draw the fuel into the airstream.

Modern fuel injection systems are designed specifically for the type of fuel being used. Some systems are designed for multiple grades of fuel (using sensors to adapt the tuning for the fuel currently used). Most fuel injection systems are for gasoline or diesel applications.

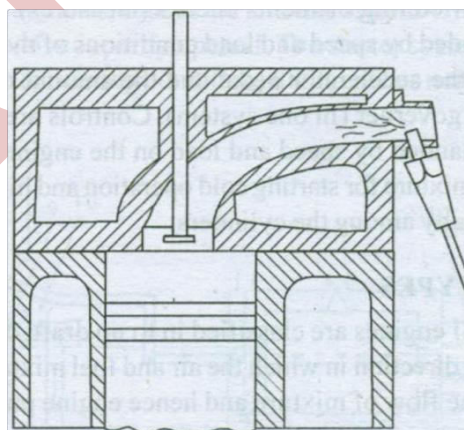
Different methods of fuel injection in a 4 stroke and 2 stroke engines are as shown in fig. (a), (b) & (c). In the manifold injection and port injection arrangements, the injector is moved farther from the combustion chamber. This provides a longer period for mixing and warming the charge.



**Fig: (a) Direct injection system**



**Fig: (b) Port injection system**



**Fig: (c) Throttle body injection**

The manifold injection system may be of two types. Single point and multipoint injection. In the first type one or two injectors are mounted inside the throttle body assembly. Fuel is sprayed at one point or location at the center inlet of the engine intake manifold. Hence this method is also called throttle body injection. The later type has one injector for each engine cylinder and fuel is sprayed in more than one location. Port injection employs individual injectors delivering locally to each port.

In SI engine continuous injection, or timed injection system is used. The later type consists of a fuel supply pump to supply fuel at low pressure (2 bars). A fuel metering or injection pump and nozzle are present. The nozzle injects the fuel in the manifold or cylinder head port. In some design, the fuel is injected directly into the combustion chamber.

Timed fuel injection system injects fuel usually during the first half of the suction stroke. Injection begins after closure of the exhaust valve. This eliminates fuel loss during scavenging. Injection ends usually not later than  $120^\circ$  after TDC, for maximum power output.

#### **Advantages:**

1. Improves fuel distribution in multi cylinder engine.
2. Increases volumetric efficiency.
3. Reduces loss of fuel during scavenging.
4. Eliminates detonation.

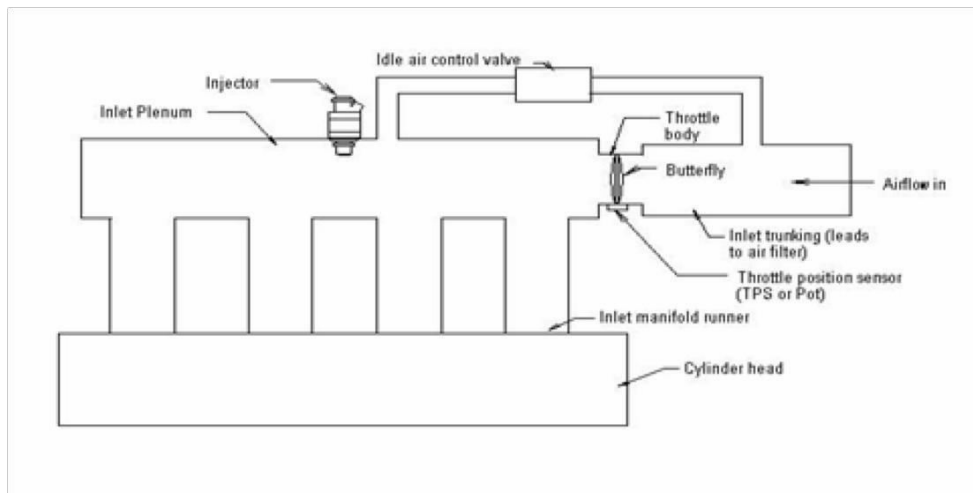
#### **Components of the Injection System**

The fuel injection system consists of a number of components to perform the tasks like metering, atomization and distribution of fuel in the air mass. Depending on speed and load of the engine, the injection system must also maintain the required air fuel ratio.

Pumping elements includes necessary piping, filter etc., and are used to move the fuel from fuel tank to the cylinders. Metering elements checks (measures) the correct quantity of fuel and delivers it at the rate demanded by speed and load conditions of the engine. The metering units are controlled by a linkage to the accelerator pedal and the amount of fuel supplied by the pump is controlled by a centrifugal governor (in one system). Controls are provided to adjust the mixture strength (A/F ratio) as demanded by speed and load on the engine. Different controls are used to increase the richness of the mixture for starting cold operation and high speeds. Distributing elements divide the metered fuel equally among the cylinders.

#### **Single-point or throttle body injection (TBI)**

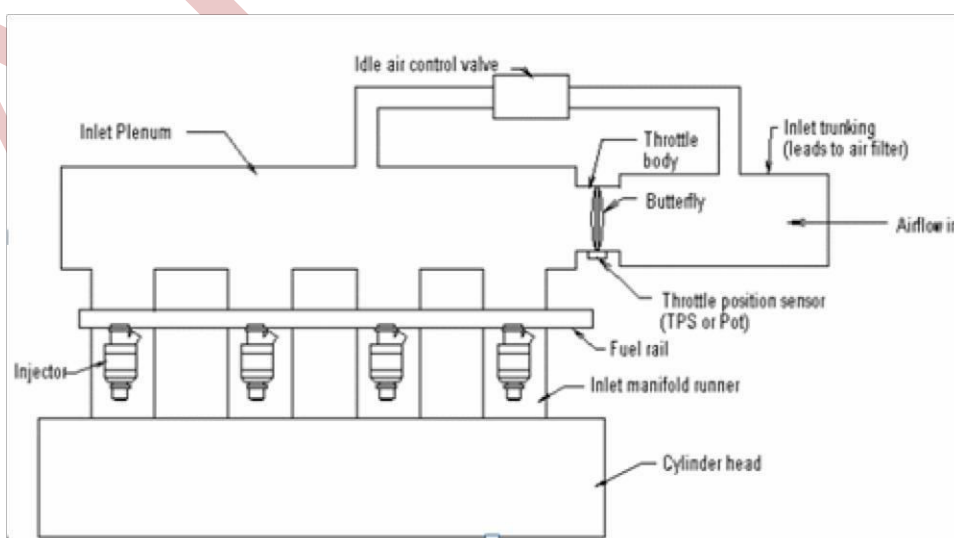
The earliest and simplest type of fuel injection, single-point simply replaces the carburetor with one or two fuel-injector nozzles in the throttle body, which is the throat of the engine's air intake manifold. For some automakers, single-point injection was a stepping stone to the more complex multi-point system. Though not as precise as the systems that have followed, TBI meters fuel better than a carburetor and is less expensive and easier to service.



**Fig: Single point injection**

**Port or multi-point fuel injection (MPFI)**

Multi-point fuel injection devotes a separate injector nozzle to each cylinder, right outside its intake port, which is why the system is sometimes called port injection. Shooting the fuel vapor this close to the intake port almost ensures that it will be drawn completely into the cylinder. The main advantage is that MPFI meters fuel more precisely than do TBI designs, better achieving the desired air/fuel ratio and improving all related aspects. Also, it virtually eliminates the possibility that fuel will condense or collect in the intake manifold. With TBI and carburetors, the intake manifold must be designed to conduct the engine’s heat, a measure to vaporize liquid fuel. This is unnecessary on engines equipped with MPFI, so the intake manifold can be formed from lighter-weight material, even plastic. Incremental fuel economy improvements result. Also, where conventional metal intake manifolds must be located atop the engine to conduct heat, those used in MPFI can be placed more creatively, granting engineers design flexibility.



**Fig : Multipoint injection**

### Types of Fuel Injection Systems:

#### Throttle body injectors or Single Point Injectors (TBI)

Single-point injection was a first step before the more complex multi-point systems came about. Not as precise as the systems that have evolved, TBI metered fuel better than a carburetor and was less expensive and easier to service.

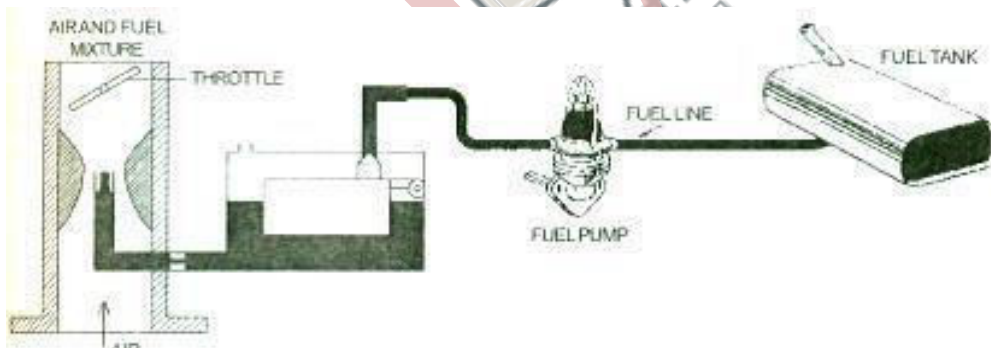
#### Port or multi-point fuel injection (MPFI)

Multi-point fuel injection has a separate injector nozzle for each cylinder, just outside its intake port, which is why the system is sometimes called port injection. Delivering the fuel vapor this close to the intake port ensures that it will be drawn completely into the cylinder. The primary advantage is that MPFI meters fuel more precisely than TBI, achieving the desired air/fuel ratio. MPFI lessens the possibility that fuel will condense in the intake manifold.

#### Sequential fuel injection (SFI)

Sometimes called sequential port fuel injection (SPFI) or timed injection, SFI is a type of multi-port injection. Though basic MPFI uses multiple injectors that spray their fuel at the same time or in groups. Sequential fuel injection triggers each injector nozzle independently and is timed like spark plugs. SFI sprays the fuel immediately before or as the intake valve opens.

### FUEL FEED SYSTEM OF CARBURETTOR ENGINES



**Fig: Automobile fuel supply system**

The functions of the fuel feed system are to store fuel for the automobile engines, to supply it to the carburetor in the required amounts and in proper condition. It also provides an indication to the driver of the amount of fuel in the tank. In a S.I. Engine, the fuel supply system consists of a fuel tank, fuel lines, fuel pump, fuel filter, air cleaner, carburetor and inlet manifold.

#### Fuel injection pumps:

An Injection Pump is the device that pumps fuel into the cylinders of a diesel engine. Traditionally, the injection pump is driven indirectly from the crankshaft by gears, chains or a toothed belt (often the timing belt) that also drives the camshaft. It rotates at half crankshaft speed in a conventional four-stroke engine. Its timing is such that the fuel is injected only very slightly before

top dead centre of that cylinder's compression stroke. It is also common for the pump belt on gasoline engines to be driven directly from the camshaft. In some systems injection pressures can be as high as 200 MPa (30,000 PSI).

Types of Fuel Injectors:

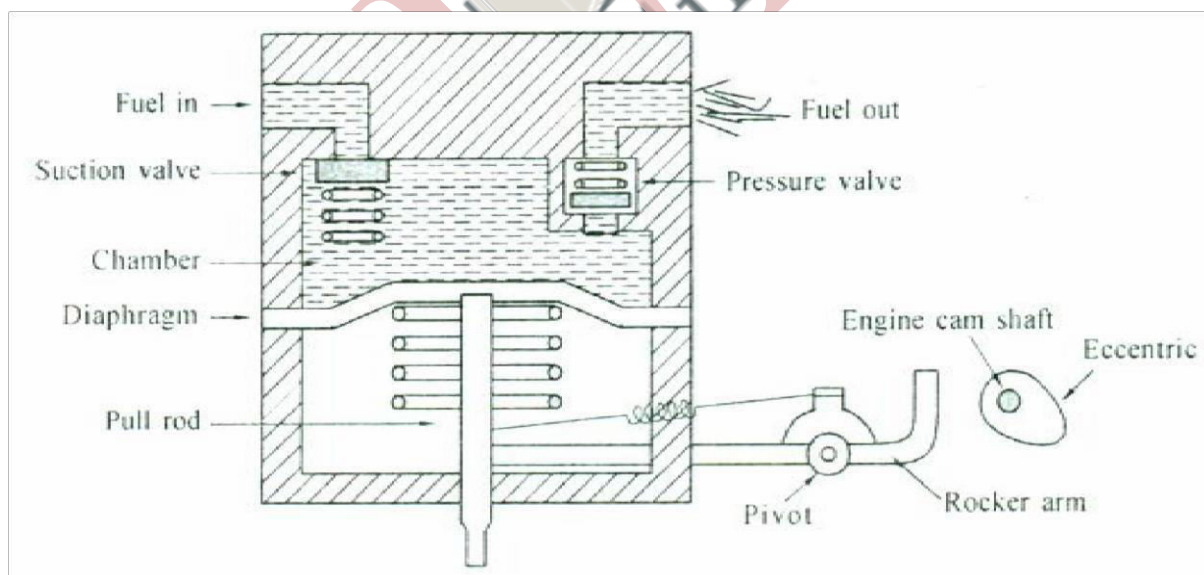
1. **Top-Feed** – Fuel enters from the in the top and exits the bottom.
2. **Side-Feed** – Fuel enters on the side on the injector fitting inside the fuel rail.
3. **Throttle Body Injectors** – (TBI) Located directly in the throttle body.

### Fuel Pumps

Many types of fuel pumps are used in the modern car fuel feed systems, all of which operate on the same principle. A fuel pump transfers petrol from the tank to carburetor [fuel injection system] through a fine grain filter. It must deliver petrol in sufficient volume at desired pressure to keep the carburetor (float chamber) full of petrol, irrespective of engine speed.

There are two types of pumps which are most commonly used

1. Mechanical type fuel transfer pump [A.C. Mechanical pump].
2. Electrical fuel pump [So U. Electrical pump]



**Fig: Mechanical Fuel pump**

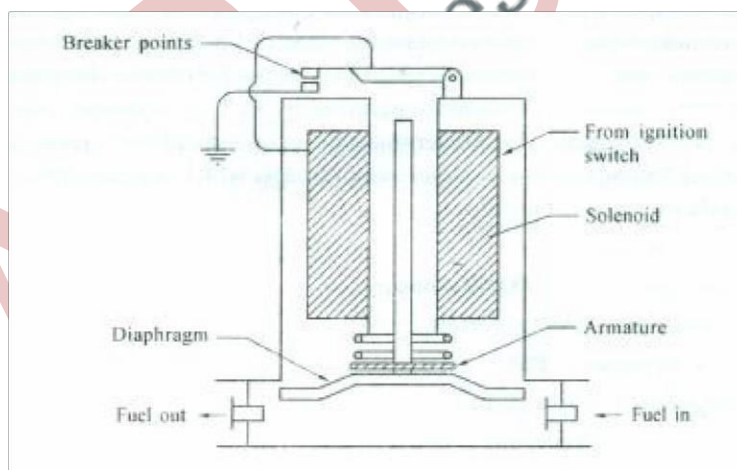
**(a) Mechanical Fuel Pump:** A mechanically operated diaphragm type fuel pump is shown in figure. It is mounted on the engine and is operated by an eccentric mounted on the cam shaft of the engine. The pump consists of a spring loaded flexible diaphragm actuated by a rocker arm which in turn operated by an eccentric. Inlet and outlet (spring loaded) valves are provided to ensure fuel flow in the proper direction. As rocker arm is moved by the eccentric, the diaphragm is pulled down, causes

a partial vacuum in the chamber. This causes the inlet valve to open and admits fuel into the pump chamber through strainer. Further rotation of the eccentric will release the rocker arm and diaphragm moves upward, causes inlet valve to close while the outlet valve opens and hence the pump delivers fuel to the carburetor (float chamber).

When the float chamber is full of petrol, pumping of more fuel is not needed till some of it is consumed. If the engine runs continuously at light loads, the cam shaft will be running all the time and there is excessive pressure in the pump. This may damage the pump itself. To avoid this the rocker arm and pull rod connection is made flexible and when the float chamber is full, the diaphragm is not operated though the cam shaft is running.

**(b) Electrical Fuel Pump:** This pump contains a flexible diaphragm which is operated by electrical means [Electro magnet]. The middle of the diaphragm is fixed to an armature. A rod extends from middle of diaphragm and passes through a center hole in the electro magnet (solenoid). The other end of the rod carries electrical contact points. Return springs are used to keep the diaphragm in position. Closing the ignition switch, energises the electromagnetic winding. Thus magnetic flux is generated which pulls the armature compressing the return spring and there by moves the diaphragm up. This causes suction in the pump chamber and fuel is drawn into the chamber through inlet valve. But as the armature moves, the rod disconnects the breaker points and thus interrupts the electric supply. The electro magnet is de-energized and the armature falls back due to spring action. This causes the diaphragm to move down creating pressure in the chamber to open outlet valve. Thus fuel is delivered to the float chamber. The cycle repeats and fuel continues to be pumped.

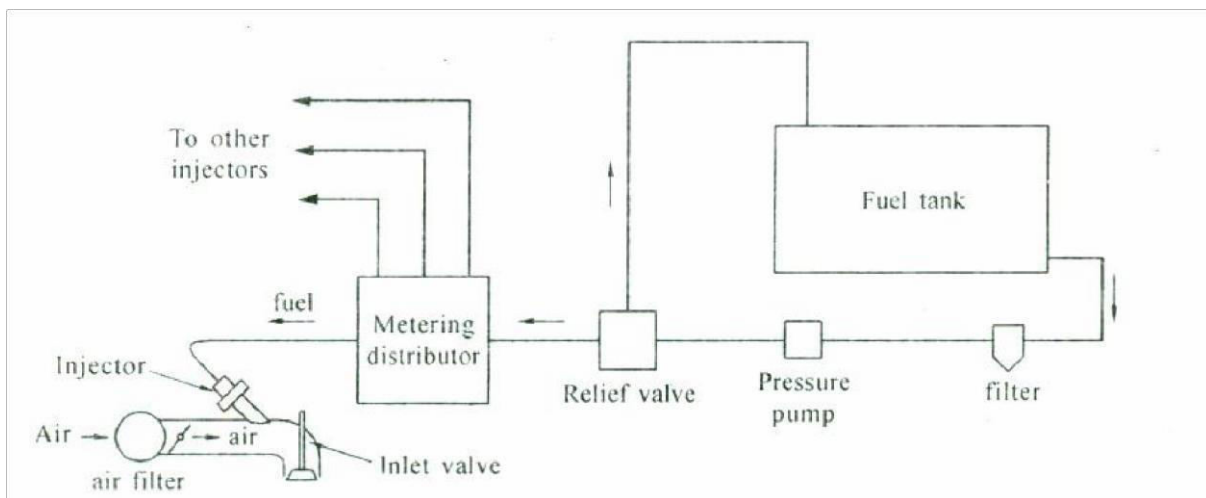
These pumps need not be located close to the engine. These electrical pumps are located near the fuel tank and are not subjected to engine heat. These pumps start operating immediately as the ignition is switched on.



**Fig: Electrical pump [S.U. type]**

## Fuel Injectors

Depending on the method of fuel control the injectors are classified into (1) Mechanical and (2) Electronic type. Mechanical method is obsolete now. A governor was used to control fuel supply and a fuel distributor was used to send the fuel to correct injector.

**(1) Mechanical Fuel injection:****Fig.: Mechanical Petrol Injection System**

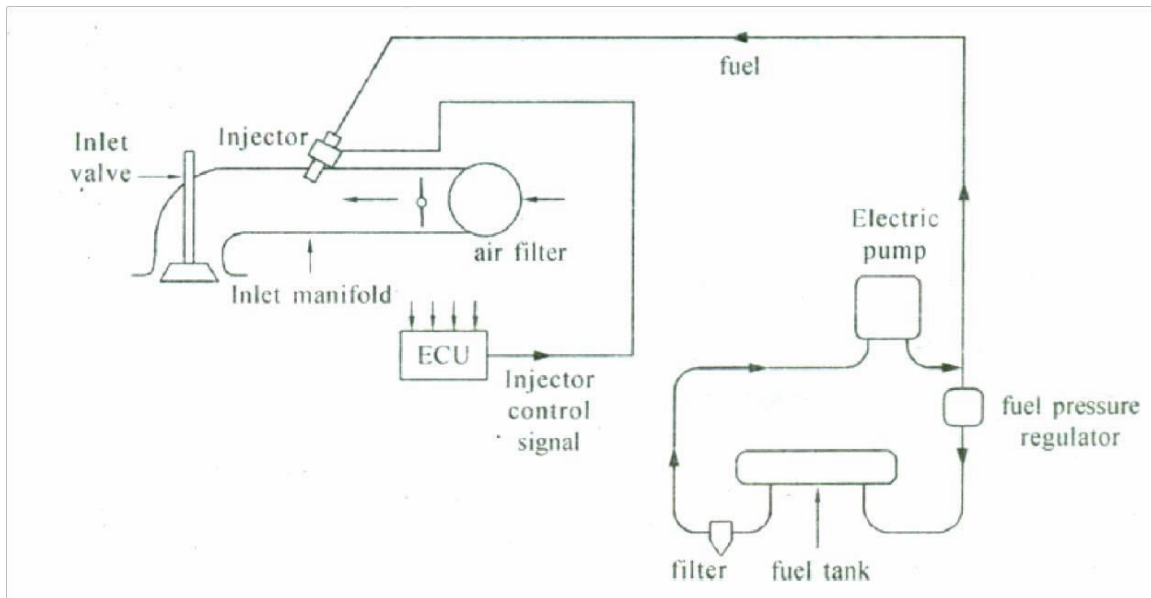
In this system an electrically driven fuel pump delivers the fuel at a specified pressure (700 kpa) into a metering distributor. The relief valve returns excess fuel to the tank and thus maintains the metering distributor at constant pressure. The metering distributor supplies fuel to each injector in turn. The quantity of fuel delivered is also controlled in the distributor by engine manifold pressure. The injector is held closed until the fuel pressure opens it to deliver atomized spray of fuel.

**(2) Electronic Fuel Injection:**

An electric fuel pump draws the fuel from the tank through a filter and supplies the same to the injectors at a pressure which is held constant by means of a fuel pressure regulator which returns excess fuel to the tank. This prevents vapour lock in the fuel lines. The injectors are held closed by spring and are opened by solenoids energized by ECU (electronic control unit). The strength of the ECU control signal, which determines the open time of the injector to control the amount of fuel injected depends upon the engine requirements which are determined by the ECU from the sensor signals from critical locations.

The common sensors used are

1. Manifold absolute pressure (MAP) sensor.
2. Barometric pressure (BARO) sensor.
3. Throttle position sensor (TPS)
4. Coolant temperature sensor (CTS).
5. Vehicle speed sensor (VSS) etc.



**Fig: Electronic Fuel Injection System**

### Fuel gauges

All automobiles are equipped with an electrically operated fuel gauge for indicating level of fuel in the tank. Two types of fuel gauges are used on automobile bodies. They are - Thermostatic type and Electromagnetic type. Both incorporate sending unit and a receiving unit.

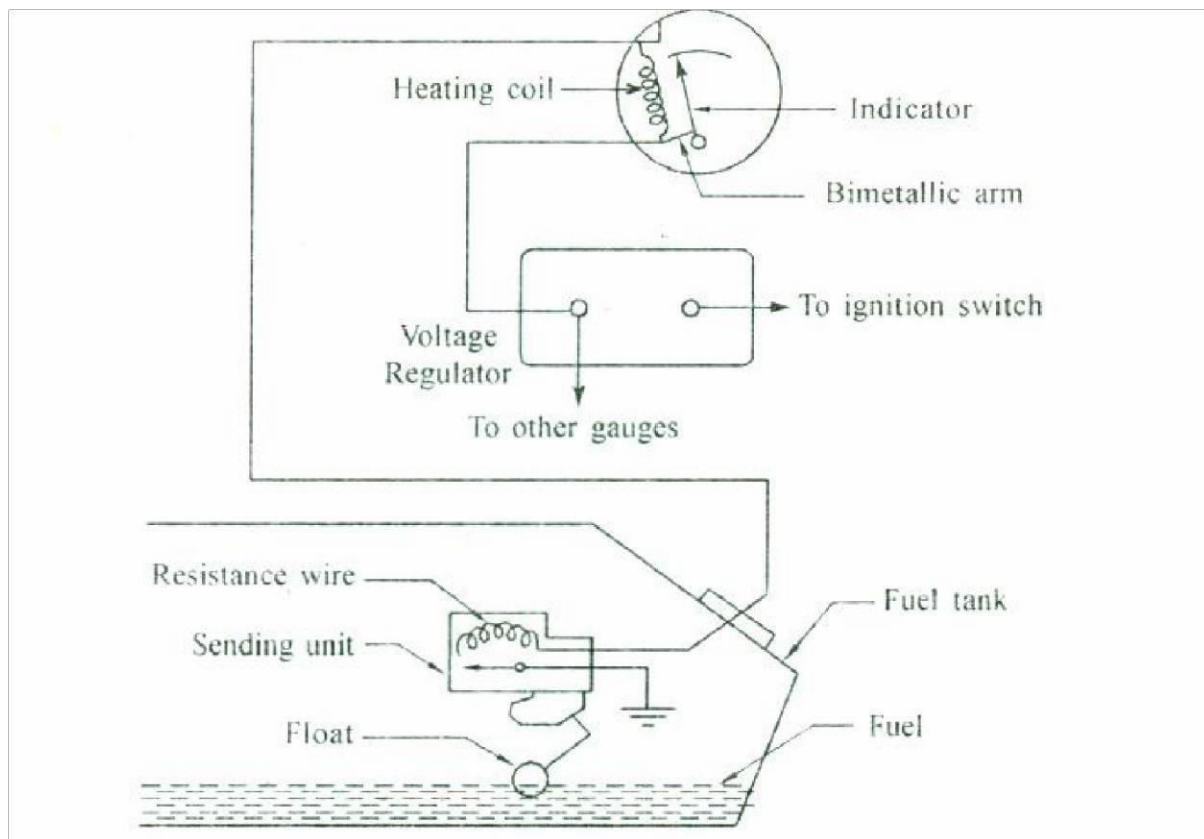
**(a) Sending Unit:** It consists of a float controlled rheostat or variable resistor. The unit is mounted on the fuel tank with float and float arm extending into the tank. The float always follows the level of the fuel in the tank. The float position determines the amount of electrical resistance within the variable resistor which controls the amount of electricity sent to the receiving unit on the instrument panel.

**(b) Receiving Unit:** It is mounted on the instrument panel and by the amount of electricity received from the sending unit indicates, on a calibrated gauge the amount of fuel in the tank.

### Thermostatic Fuel Gauge

Here the receiving unit contains a heating coil. When the fuel tank is low at grounded sliding contact in the sending unit controlled by the float is near the end of variable resistance wire and sends only a small amount of current to the heating coil in the receiving unit. The heating coil activates a bimetallic arm which moves the gauge pointer to the 'E' (empty) position. When the tank is filled, the float rises with the fuel level and moves the grounded sliding contact toward the beginning of the resistance wire. Thus electrical resistance decreases and current flowing to the receiving unit increases. The heating coil in the receiving unit generates more heat and moves the pointer to the 'F' (full) position.





**Fig: Fuel gauge**

A fine mesh gauge is used as a filter to clean the petrol. It is more suitable where petrol contains very large dust particles, but not so effective in preventing the fine particles and the water from going inside the cylinder. Ordinary chamois leather which is first moistened with petrol can be used as an effective device which allows only petrol to pass through it and water will be intercepted. Fine grit, of course cannot pass through it.

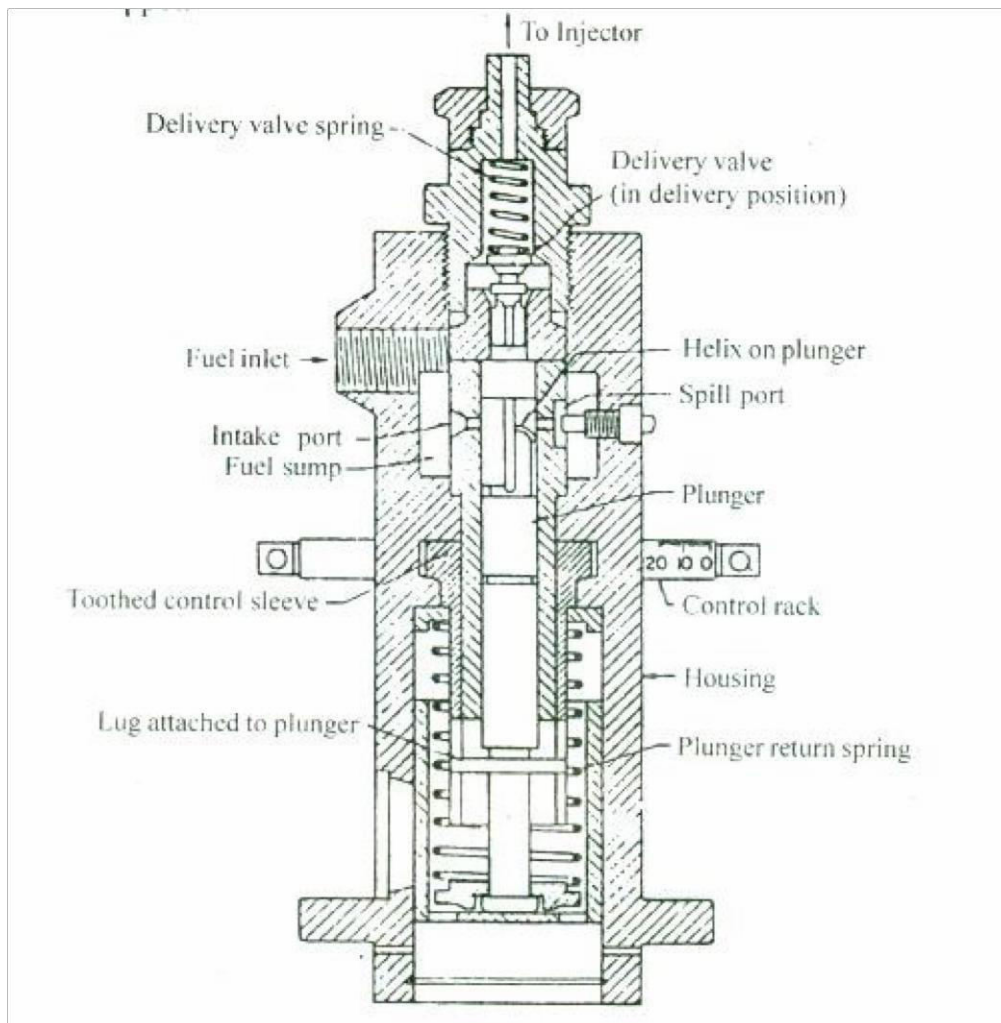
## FUEL INJECTION PUMP

The fuel injection pump delivers accurately, metered quantity of fuel under high pressure, at the correct instant and in the correct sequence, to the injector fitted on each engine cylinder. In most of the engines the injection pressure ranges from 7 to 30 MPa and in some cases it may be as high as 200 MPa. The timing gears drive the injection pumps and its output is controlled by drives through accelerator pedal. The injection system has to deliver very small volume of fuel; hence the volume of fuel to be metered is very small for each injection. The frequency of injection is quite high. For example, in a 4 stroke, 4 cylinder diesel engine, at maximum speed of 6000 rpm, about 150 rpm of fuel is to be metered and injected 20 times in a second. In a two stroke engine the numbers of injections per second are twice this value. Generally the fuel injection pumps are classified into jerk pump type and distributor type;

### (a) Jerk Pump type fuel injection pump:

A single cylinder jerk pump type fuel injection pump is as shown in figure. It consists of a

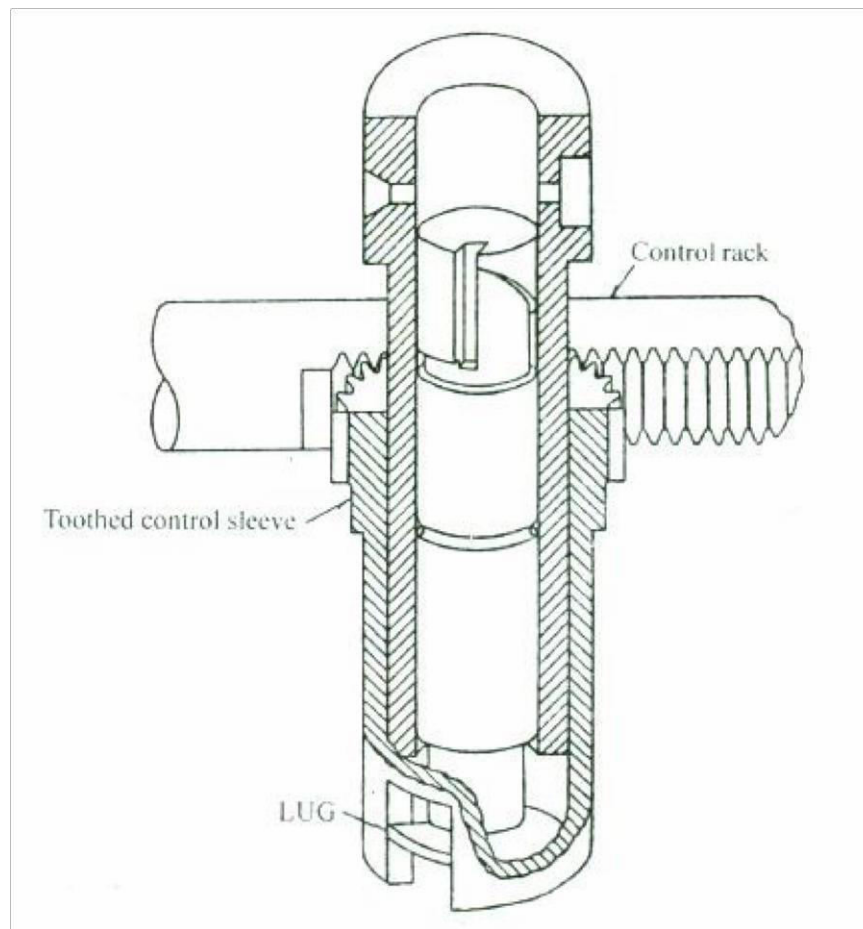
spring loaded delivery valve, plunger, control sleeve and control rack. The fuel quantity to be injected is controlled by the plunger which contains a helix at its top end. The plunger in turn is operated by using a cam and tappet.



**Fig: Single cylinder jerk type fuel injection pump**

In this pump, the plunger stroke remains constant, but the effective stroke is reduced by changing the position of helix on the plunger with respect to fuel inlet port. The cam produces forward or delivery stroke and the action of spring returns the plunger. As the plunger performs down ward stroke, it uncovers the inlet port present in the barrel at atmospheric pressure and fills the space above the plunger and also vertical groove and space below the helix. When the plunger raises up, it covers the ports and compresses the fuel. The compressed fuel lifts the delivery valve and it is supplied to the injector through the delivery valve. As the plunger moves up wards, the spill port will be uncovered by the plunger helix and the helical groove on the plunger connects the space above the plunger with the suction line. The oil at high pressure in the space above the plunger is by passed back in to the pump and there by decreases pressure near the delivery valve. This closes the delivery valve due to action of spring. The fuel quantity delivered through the delivery valve depends upon the opening position of the spill port with respect to helical groove. Depending on the load on the

engine, the position of helical groove with respect to spill port can be changed by rotating plunger with control rack. The quantity of fuel can be varied from zero to that required at full load by changing the positions of the rack.



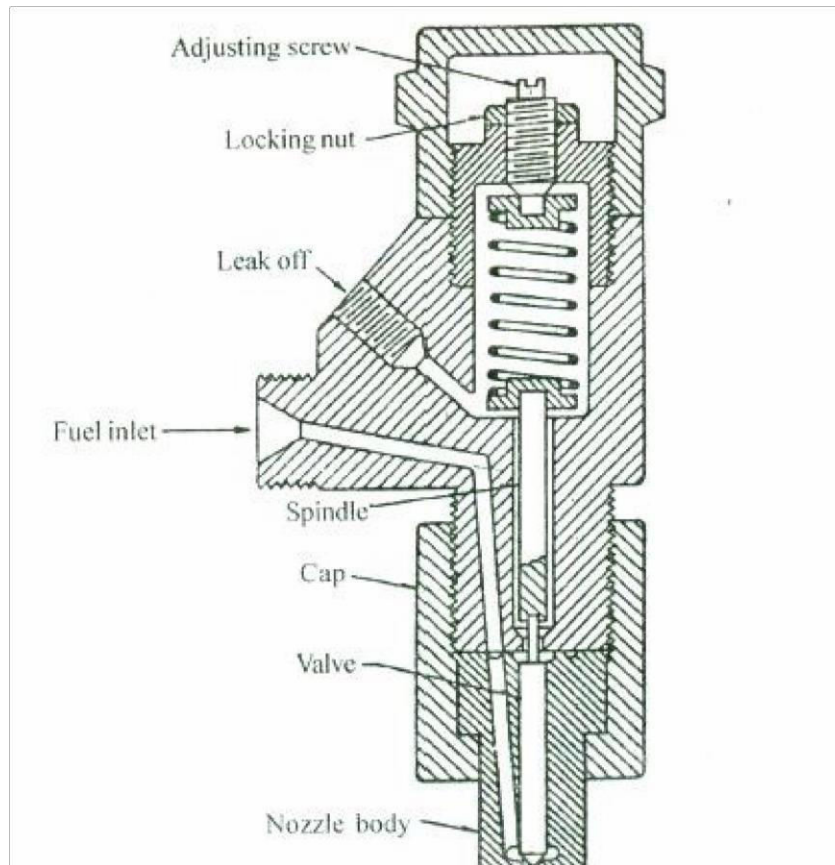
**Fig: Arrangement showing the control of fuel delivery**

## FUEL INJECTOR

The fuel injector is used

- i) To atomize the fuel to the required degree of fineness.
- ii) To distribute the fuel for proper mixing of fuel and air.
- iii) To prevent fuel injection on cylinder walls and top of the piston.
- iv) The fuel injection must start stop instantaneously.

A spring loaded fuel injector is as shown in figure. The fuel pump supplies fuel to the injector and high pressure fuel lifts the spring loaded valve. The fuel is then injected into the combustion chamber of the engine cylinder. As the pressure decreases, the valve is automatically closed by the spring force. The duration of open period of the valve controls the amount of fuel injected in to the combustion chamber.



**Fig: Fuel Injector**

## GOVERNING AND FUEL CONTROL

Governors are used on engines to keep their speeds below a set maximum. Governors maintain engine speed constant irrespective of changes in the load. The governor is usually placed between carburetor and intake manifold. Vacuum and centrifugal type governors are most commonly used. The operation of vacuum type depends on the pressure of the moving fuel and air mixture. When this pressure reaches a set value, the fuel mixture is not permitted to enter the engine at a faster rate. The centrifugal type is attached to the cam shaft by a gear drive. The fly weight movement attached to pivot arms of governor is used to control the flow of mixture in the carburetor, thus controls the engine speed. If the engine load decreases the speed of engine will begin to increase, if the fuel supply is not decreased and if load increases, speed begins to decrease, if fuel supply is not increased. The governor supplies fuel to the engine depending on engine load and thus maintain the speed constant. Different methods are used to control the flow of fuel and hence controls the speed according to load.

They are

1. **Hit and Miss Method:** In this method, the fuel supply is completely cut off during few cycles of the engine. This is generally used in gas engines.
2. **Quality Governing:** Depending on the engine load, the fuel supply per cycle of the engine is

varied i.e. A:F ratio is changed depending on the engine load. At high loads rich mixture is supplied and lean mixture is supplied at low loads. This method is used for diesel engines.

- 3. Quantity Governing:** In this method, the quantity of air fuel mixture supplied is varied according to engine load. The A/F ratio of the mixture supplied to the engine at all loads remain nearly constant. This is used for Petrol engines.

ARUN.R



**UNIT - 3****SUPER CHARGERS AND TURBO CHARGERS****INTRODUCTION**

The power developed by a naturally aspirated engine depends upon

- i) Amount of air introduced into cylinder per cycle
- ii) Degree of utilization of the inducted air
- iii) The engine speed and thermal efficiency
- iv) Quantity of fuel admitted and its combustion characteristics.

By increasing engine speed or by increasing air density at the inlet, it is possible to increase the amount of air inducted into engine cylinder per unit time. As engine speed increases, inertia load increases and this calls for rigid and robust engine to withstand stresses. Also higher engine speed causes decrease in volumetric efficiency, higher friction and increased bearing loads. The method of increasing the inlet air density is called super charging. This increases power output of the engine. The super charging is achieved by supply in air or air-fuel mixture at a pressure higher than the pressure at which the engine naturally aspirates air. This increases air density and hence mass of air or air fuel mixture inducted for the same swept volume and thereby increases power output of the engine. A device called super charger is used to increase the pressure of air.

The power output of the engine can also be increased by increasing compression ratio. The high compression ratio results in increase of Brake mean effective pressure and the maximum cylinder pressure. For a given maximum cylinder pressure more power can be obtained by super charging compared to that obtained by raising compression ratio. The increase in compression ratio also increases exhaust temperature and results in higher thermal loads. Turbo charging uses energy of exhaust gases to drive a turbine that increases inlet air density.

**Forced induction**

Forced induction is the process of delivering compressed air to the intake of an internal combustion engine. A forced induction engine uses a gas compressor to increase the pressure, temperature and density of the air. An engine without forced induction is considered a naturally aspirated engine.

Forced induction is used in the automotive and aviation industry to increase engine power and efficiency. A forced induction engine is essentially two compressors in series. The compression stroke of the engine is the main compression that every engine has. An additional compressor feeding into the intake of the engine makes it a forced induction. A compressor feeding pressure into another greatly increases the total compression ratio of the entire system. This intake pressure is called boost. This particularly helps aviation engines, as they need to operate at high altitude.

Higher compression engines have the benefit of maximizing the amount of useful energy extracted per unit of fuel. Therefore, the thermal efficiency of the engine is increased in accordance with the vapor power cycle analysis of the second law of thermodynamics. The reason all engines are not higher compression is because for any given octane, the fuel will prematurely detonate with a higher than normal compression ratio. This is called pre-ignition, detonation or knock and can cause severe engine damage. High compression on a naturally aspirated engine can reach the detonation threshold fairly easily. However, a forced induction engine can have a higher total compression without detonation because the air charge can be cooled after the first stage of compression, using an intercooler.

One of the primary concerns in internal combustion emissions is a factor called the NO<sub>x</sub> fraction, or the amount of nitrogen/oxygen compounds the engine produces. This level is government regulated for emissions as commonly seen at inspection stations. High compression causes high combustion temperatures. High combustion temperatures lead to higher NO<sub>x</sub> emissions, thus forced induction can give higher NO<sub>x</sub> fractions.

### **Supercharger**

A supercharger is an air compressor that increases the pressure or density of air supplied to an internal combustion engine. This gives each intake cycle of the engine more oxygen, letting it burn more fuel and do more work, thus increasing power.

Power for the supercharger can be provided mechanically by means of a belt, gear, shaft, or chain connected to the engine's crankshaft. When power is provided by a turbine powered by exhaust gas, a supercharger is known as a turbo supercharger— typically referred to simply as a turbocharger or just turbo. Common usage restricts the term supercharger to mechanically driven units.

### **General Overview of Superchargers**

Superchargers are an external mechanism driven off the engine's auxiliary drive belt. The mechanism can work in many fashions, but all have the same basic effect: to increase the force on the incoming air to the engine. Since superchargers are belt-driven, they do create small amounts of parasitic drag on the engine, however the effects of the supercharger greatly outweigh the drag.

Generally, superchargers work with gear ratios to create the desired speed of the impeller (or other air-moving mechanism). If less boost is desired, a larger drive-pulley can be interchanged onto the supercharger. If greater boost is desired, a smaller pulley is used.

However, boost levels can be controlled in other ways too. A waste gate or blow-off-valve can be used in conjunction with a correctly sized pulley to have great control over boost levels.

The points to be noted during super charging are

1. It increases power output of the engine
2. Super charging results in higher forces. The engine should be designed to with stand these higher forces.
3. The power required for air compression has to be taken from engine itself. But net power output

will be more than power output without super charging for the same capacity.

4. The higher pressure and temperature may lead to detonation. Therefore fuel with better antiknock characteristics is required.

### OBJECTIVES OF SUPER CHARGING

Mainly super charging is done to induct more amount of air into cylinder per unit time and hence to burn more amount of fuel to increase power output. Following are the objectives of supercharging

1. For a given weight and bulk of the engine, super-charging increases power output. This is important in air craft, marine and automotive engines where weight and space are considered
2. To obtain better performance from the existing engine
3. To compensate for loss of power due to high altitudes for air craft engines

### ADVANTAGES AND DISADVANTAGES OF SUPER CHARGING

#### Advantages

1. Power output of the engine can be increased
2. More quantity of charge can be inducted in to engine cylinder
3. Better atomization of fuel is possible
4. Better mixing of air and fuel can be obtained
5. Better scavenging of exhaust gases is possible
6. Torque is improved for whole speed range and better torque at low speeds
7. Faster acceleration of the engine is possible
8. The specific fuel consumption is lowered slightly
9. A better mechanical efficiency and efficient combustion is possible
- 10 In CI engines, exhaust smoke is reduced

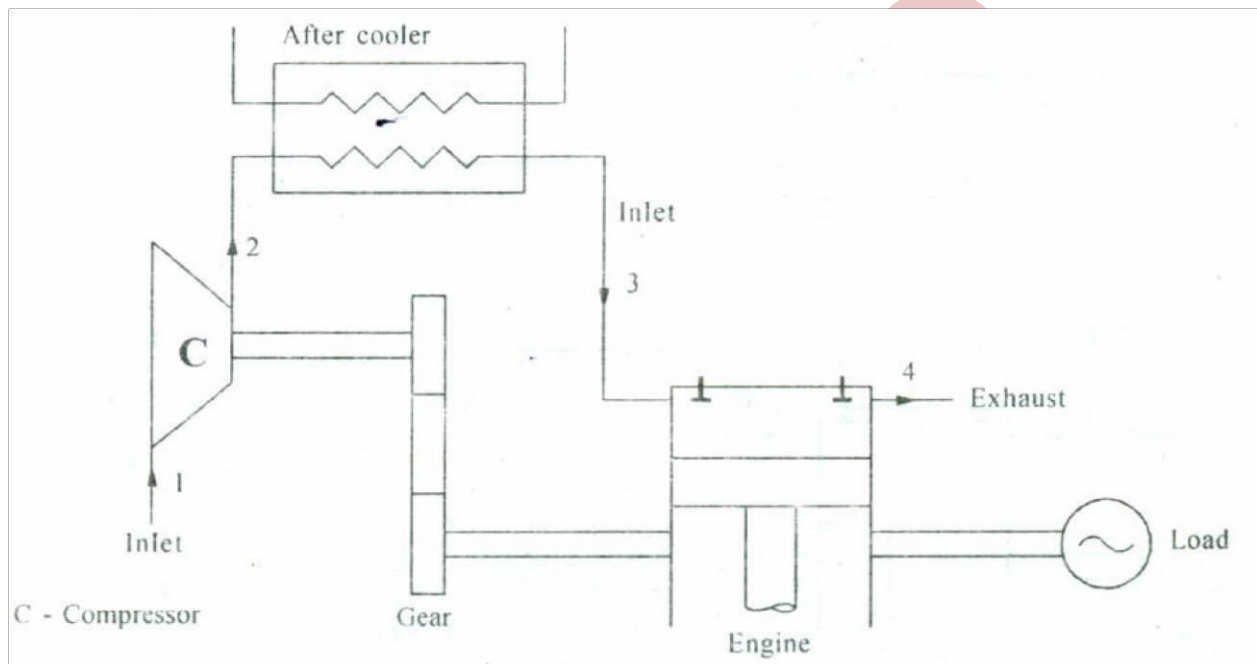
#### Disadvantages

1. Detonation tendency increases in SI engines
2. Heat losses due to turbulence and thermal stresses are more
3. The valve overlap period increases up to 60° of crank angle
4. Better lubrication is required
5. Better cooling of piston and valves is required
6. It increases cost of the engine



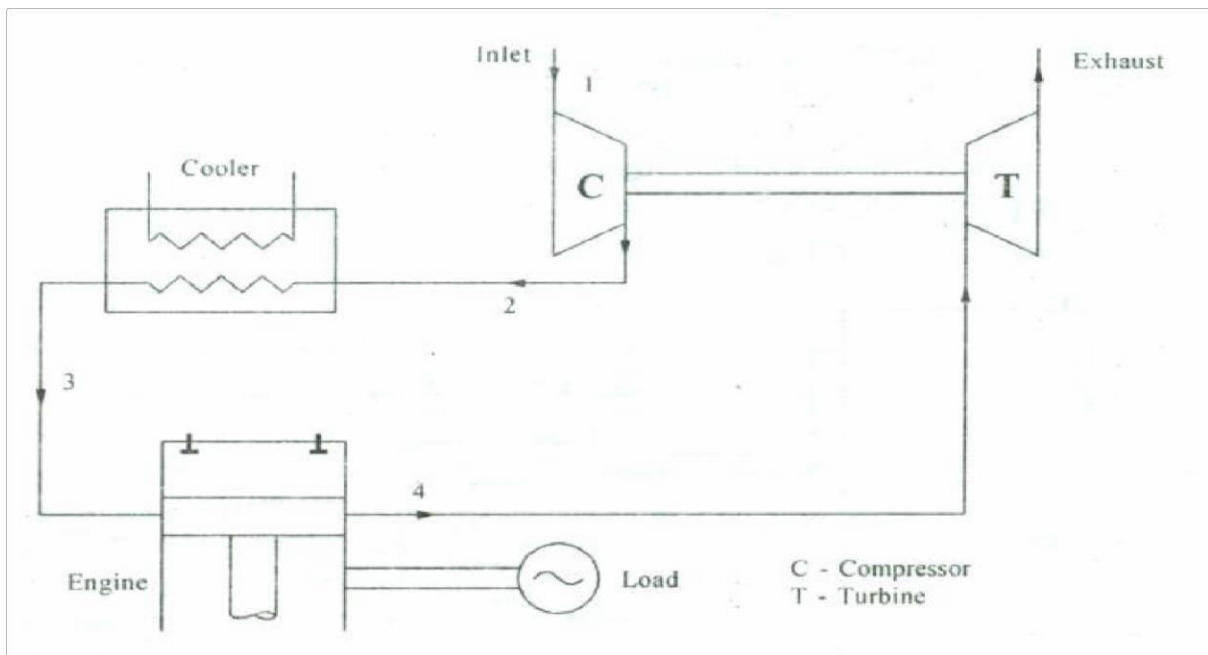
**METHODS OF SUPER CHARGING**

As discussed earlier, super charger is a pressure boosting device which supplies air (in case of diesel engine) or air-fuel mixture (in case of SI engine) to the engine cylinder at higher pressure. Different methods are used to run a super charger. The following figures show some of the arrangements used to run super charger. In the first arrangement, the engine drives a compressor which is coupled to it by using step up gearing. A part of the power developed by the engine is used to run compressor and compressor super charges the engine.



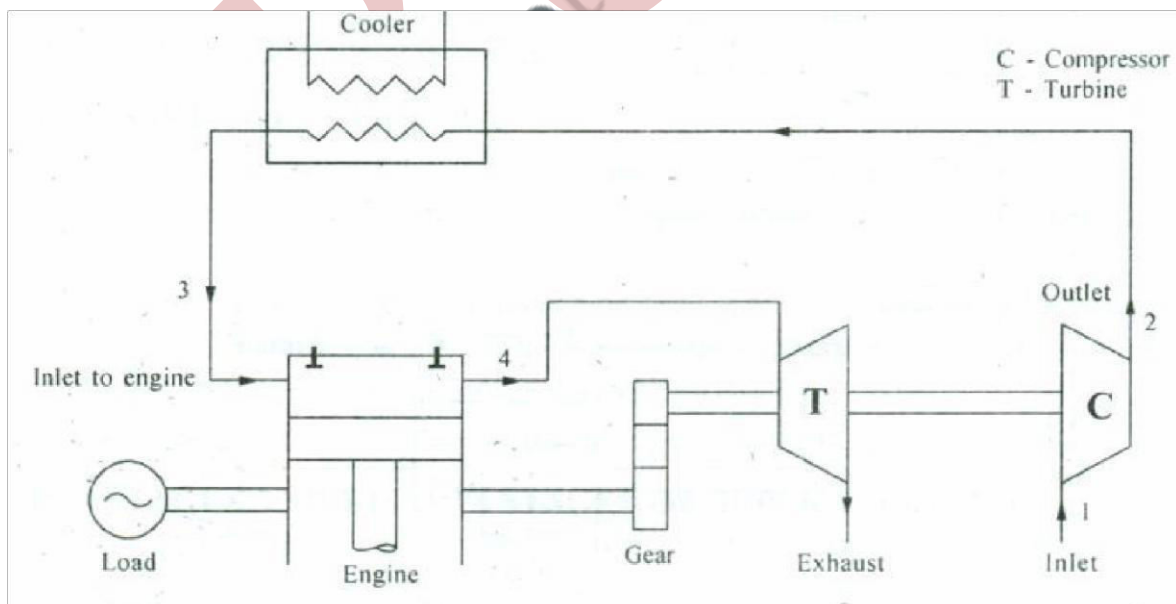
**Fig: Supercharging of engine by compressor**

In another method, a turbine coupled to the compressor is driven by engine exhaust. The turbine used in this arrangement is free from engine except that of the exhaust pipe and air inlet pipe. The power output of the engine is not used to run compressor. This is called Turbo charging.



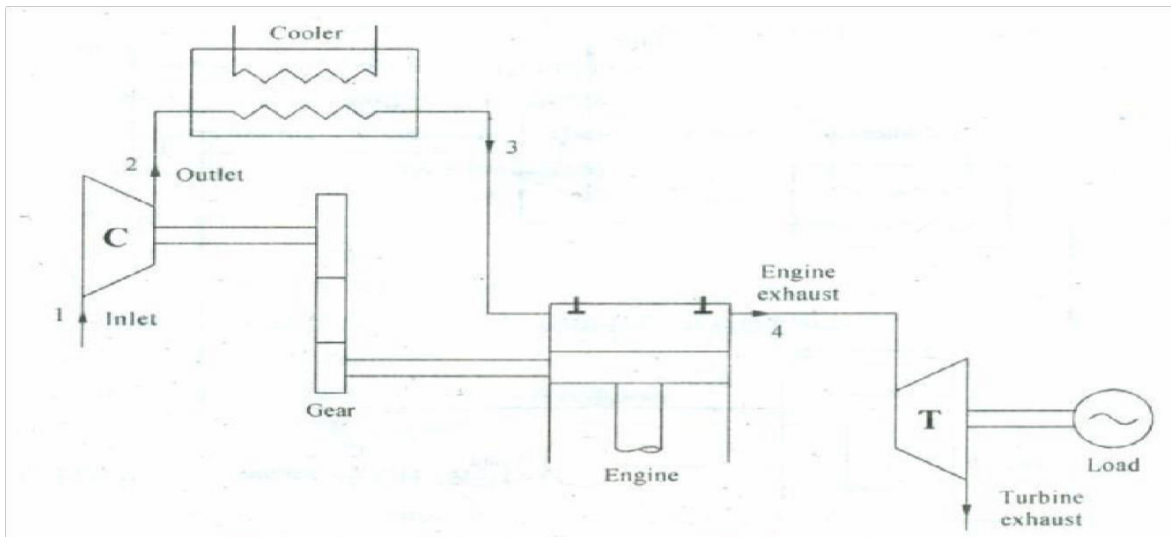
**Fig: Super charging with turbine driven by engine exhaust**

In the third method, all the components i.e., engine, turbine and compressor are coupled together with gearing. At part load, turbine develops less power which is insufficient to run the compressor. In this case, engine supplies additional power to compensate this less power of the turbine. If turbine is developing more power to run compressor, it can be supplied to engine.



**Fig: Super charging arrangement in which engine, turbine and compressor are coupled.**

In the fourth arrangement, the total power of the engine is used to run compressor and exhaust gases from engine drives a turbine to give power output. Such arrangement is also called "free piston engine". Sometimes, an electric motor drives compressor independently.

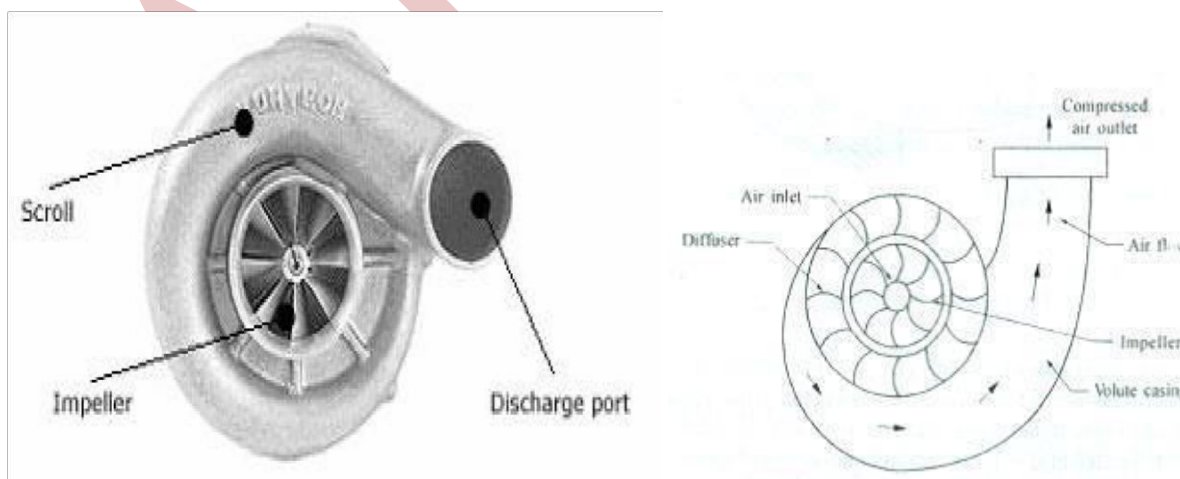


**Fig: Super charging method in which engine runs compressor and turbine develops power**

**TYPES OF SUPER CHARGERS**

Usually reciprocating compressors, displacement type rotary blowers, centrifugal compressors are used to supercharge engine for various applications. If engine crank shaft drives super charger, then it is called mechanical super charger. If the super charger is driven by a gas turbine which runs on exhaust gases from the engine, then it is called Turbo-charger. The main types of super charger are 1) Centrifugal type 2) Roots blower and 3) Vane blower.

**Centrifugal type super charger**



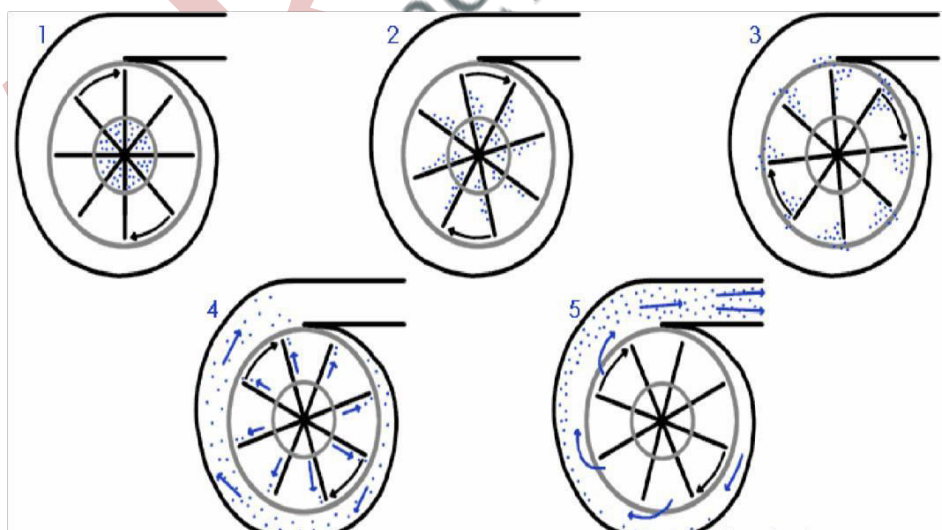
**Fig: Centrifugal type Supercharger**

This type of super charger is most commonly used in automotive engines. It consists of an impeller made of alloy steels and rotates at high speeds (about 80,000 rpm) inside a closely fitted casting. If the air enters axially at the centre of impeller and radial vanes deflect air flow by 90°. Due to centrifugal action, high velocity air from tip of radial vanes is passed to a diffuser or volute where air pressure increased and then high pressure air is supplied to the engine. This super charger is driven by engine through V-belt. Due to entry of high pressure air, 30% more air fuel mixture can be forced in to combustion chamber.

The supercharger consists of an inlet port, an impeller, a scroll, and a discharge port. The air comes in the inlet port, and is hit by an impeller. The impeller must spin at speeds of 40,000 - 60,000 rotations per minute in order to create boost. At idle speeds, the impeller does not have enough rotational speed to produce any boost. The impeller utilizes centrifugal forces in order to produce boost.

The impeller is the integral part of the centrifugal supercharger (depicted as black fins). As the air comes in at the center of the compressor blades, the impeller grabs the incoming air from the inlet port (1). Since the impeller is turning at tens-of-thousands of revolutions per minute, the air is naturally thrown back and towards the outskirts of the fins due to centrifugal forces created by its rotational inertia (2 &3). "At the outside of the blades, a "scroll" is waiting to catch the air molecules. Just before entering the scroll, the air molecules are forced to travel through a venturi (depicted as the larger grey circle), which creates the internal compression. As the air travels around the scroll (4), the diameter of the scroll increases, this slows the velocity of the air, but further increases its pressure (5)."

While a centrifugal supercharger is capable of very high levels of boost and high levels of horsepower increase, the boost doesn't occur until high RPMs are reached (normally the supercharger starts creating boost around 3000 RPMs).



**ADVANTAGES AND DISADVANTAGES OF CENTRIFUGAL SUPER CHARGER**

1. Low initial cost, less power requirement and high conversion efficiency
2. It requires less maintenance and handles any quantity of air
3. It requires more space due to larger impeller

**Roots Supercharger**

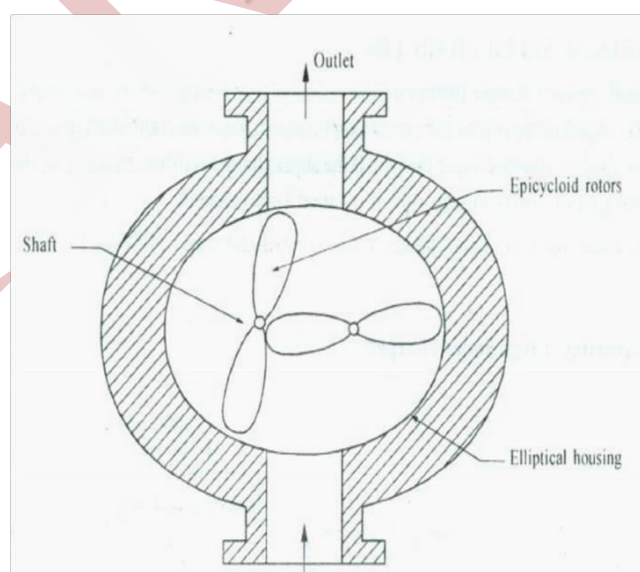
The roots supercharger is among the oldest designs for pumping air. First implemented in early 1900, it was used as an industrial air-moving device. In the past thirty years however, it has been used on many vehicles as a supercharger.

"The roots type supercharger is two counter-rotating meshed lobed rotors. The two rotors trap air in the gaps between rotors and push it against the compressor housing as they rotate towards the outlet/discharge port. During each rotation, a specific fixed amount of air is trapped and moved to the outlet port where it is compressed, which is why the roots type supercharger falls under the broader category of fixed-displacement superchargers (like the twin screw supercharger). As with all positive displacement blowers, boost is directly related to the speed of the lobes.

The roots supercharger is known for its high levels of low-rpm boost. Used often in high torque applications such as towing, the roots blower has also seen much use in top-fuel dragsters. The simplicity and low-rpm of the design make it a very reliable compressor

**ADVANTAGES AND DISADVANTAGES OF ROOT'S BLOWER SUPER CHARGERS**

1. Simple design, low capital and maintenance cost
2. The volumetric efficiency is high and better balancing is possible at high speeds.
3. Chances of leakage are more, air supply is not regular due to pulsed delivery
4. As pressure increases, volumetric efficiency of the super charger decreases.



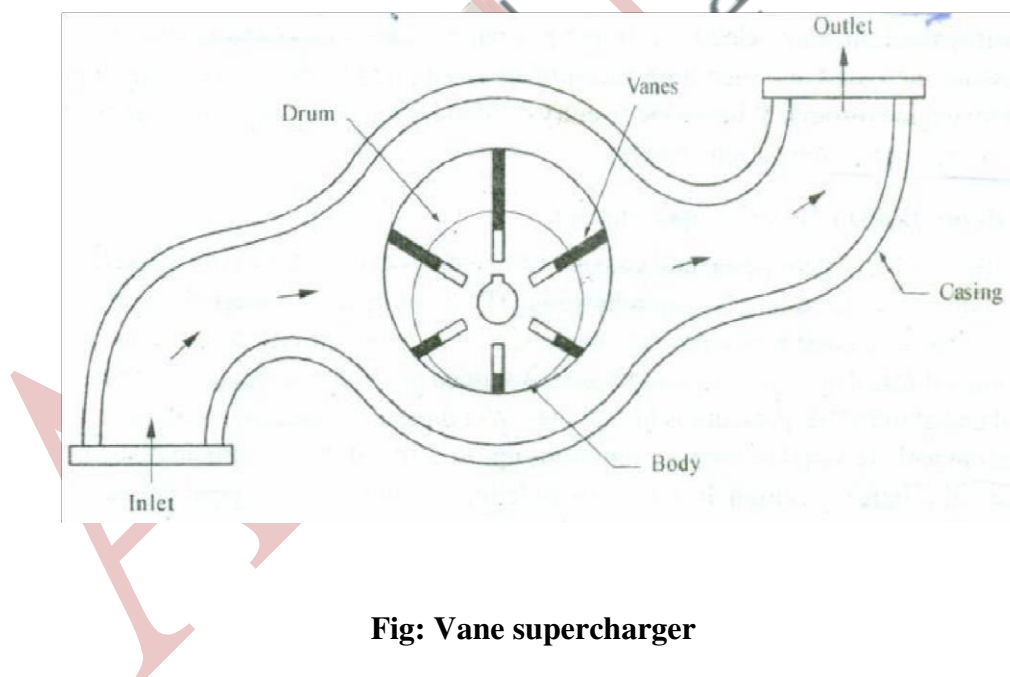
**Fig: Root Supercharger**

### Vane Blowers

It is a positive displacement rotary type super charger. This consists of a cylindrical casing, a rotor with four slots; remain in contact with casing at least at one point all the time. The rotor is eccentrically mounted and vanes slides in and out of the rotor slots in radial direction. The air is induced in the space between the blades due to outward movement of vanes, which increases the space between the blades. When the space reduces near the outlet of super charger, it discharges air. The space between inner surface of body and drum decreases from inlet to outer side. The air which enters at inlet, decreases in volume and hence pressure increases as air reaches outlet. The movement of vanes causes flow pulsating and noisy.

### ADVANTAGES AND DISADVANTAGES OF VANE BLOWERS

1. Suitable for high capacity engines
2. High pressure ratio is possible and delivers large quantity of air
3. Maintenance cost and power requirement is high.
4. The vanes rubs against cylinders and wears out rapidly



**Fig: Vane supercharger**

### SUPER CHARGING LIMITS

The parameters such as engine knock, thermal and mechanical loads limits the power output of the engine. Usually in SI engines, knock limit are reached first, where as in diesel engines thermal and mechanical loads limits are reached first. If supercharging is to be done in an existing engine, it is necessary to analyze the factors that limit the extent of super charging. This in turn depends up on engine's ability to with stand gas loading, thermal stresses, durability, reliability, fuel economy etc.

In SI engines, the extent of super charging is mainly limited by knock. The super charging

reduces ignition delay and this result in engine knock at these high pressures.

Therefore increase in super charging pressure increases the tendency to detonate. Generally for SI engines, super charging is employed only for air craft and racing car engines. The super charger pressure is in the range of 1.3 to-T.S bar, corresponds to 30 to 50% super charging.

In CI engines, super charging limits are not due to combustion. The engine runs better, smoother and quieter due to decrease in ignition delay at high super charging pressure and temperature. But the degree of super charging is limited by thermal and mechanical load on the engine and mainly depends on the type of super charger used and engine design. Also the engine reliability decreases at maximum cylinder pressure, this increases heat release rate and hence thermal load on the engine. For intake pressures less than 1.5 atm, the cost of super charging is not justified.

## TURBO CHARGING

Turbochargers are a type of superchargers. It effectively 'charges' the incoming air, which is the definition of supercharging. The turbo differs from a supercharger in that it derives its power from a different source than previously described designs. The previous designs received power from the driveshaft of the engine. Turbochargers derive their power from exhaust gasses.

Turbochargers use the power of the exhaust, much like a hydroelectric dam converts power from the water into mechanical energy. A hydroelectric dam sends water through a hydroelectric turbine. The turbine design redirects the flow of the water into a circle which is caught by fins/blades. The water turns these blades, which turns a driveshaft. When the water has released most all of its energy to the fins, the water then exits the turbine through a port at the center.

Turbo's in cars act nearly the same way except the water is replaced with exhaust from the engine. The drive shaft, in-turn, powers a centrifugal supercharger. Turbochargers are very efficient, because they do not leech off of the engine's power. The turbo has some downsides however. Boost cannot be controlled by simply changing a pulley. Boost must be controlled by a wastage or blow off valve.

Another downside to a turbocharger, is the superheating of the intake air. Since the turbine must be run by hot exhaust gasses, the heat transfers via conduction to the compressor. The compressor becomes superheated, and therefore heats the incoming air to the engine. This can be counteracted by implementing an intercooler.

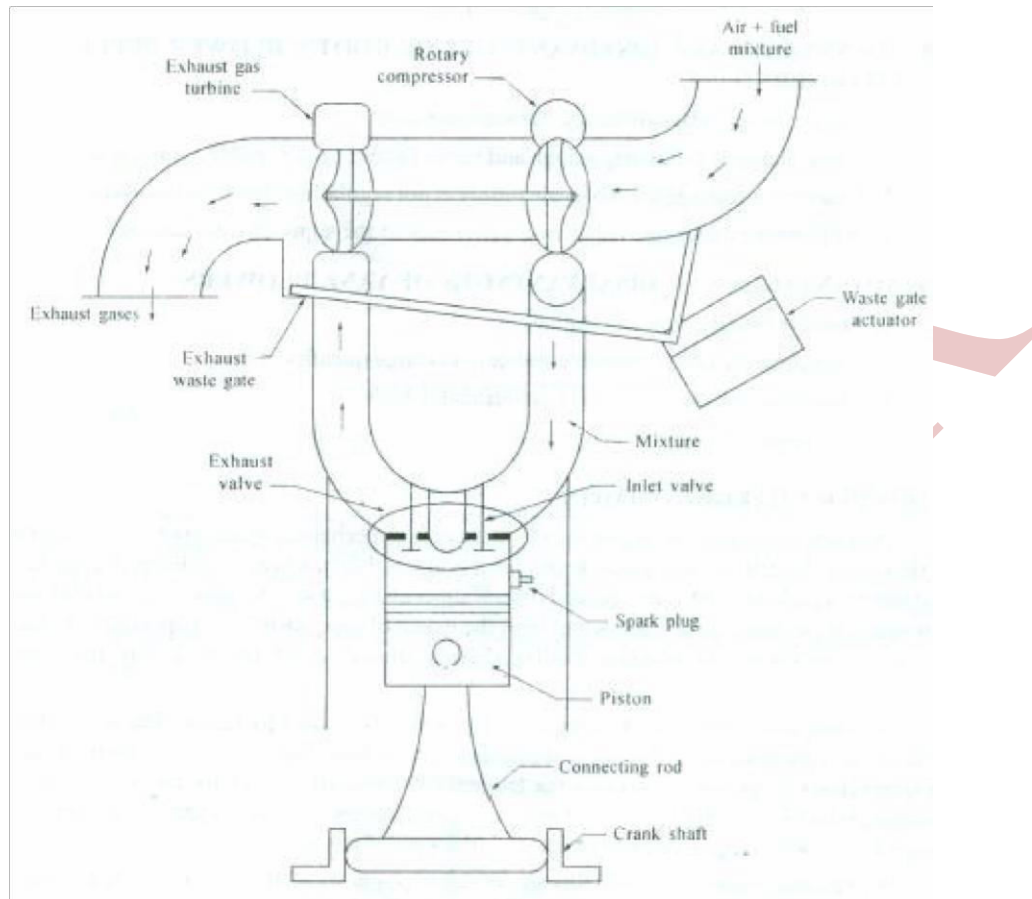
The other main con of a turbocharger is something called turbo-lag. Turbo-lag is the time it takes for the turbo to spool up and produce power. Since an engine does not create large amounts of exhaust in low RPMs, the turbo creates small amounts of boost, and must have time to gain rotational inertia from the exhaust.

Despite the added downsides, turbochargers can create very large amounts of horsepower and is able to deliver added torque that a regular centrifugal supercharger lacks.

## WORKING

The turbine uses energy from the exhaust gases to convert heat energy into rotational motion. This rotational motion of turbine drives the compressor, which draws in ambient air from the surrounding and pumps compressed air with high density and pressure into the intake manifold.

The exhaust gas enters the turbine inlet side of the turbocharger through a pressurized chamber and a series of filters. The nozzle blade rings concentrates the exhaust gas on to the turbine wheel. The movement of the turbine wheel rotates the shaft which in turn rotates the impeller of the compressor. A part of this air goes to the labyrinth seal from the outlet side of the turbine.



**Fig: Exhaust turbo charging of a single cylinder engine**

As the impeller rotates, air is sucked in through the center of the impeller and due to the heavy rotational movement, experiences circumferential velocity which pushes it outwards. A radial velocity is gained which pushes the air further outwards on to the inducer. An additional resultant velocity is gained due to the accurately designed inducer inlet angle which gives maximum compressor efficiency.

Excessive pressure leads to spoiling or fouling of the impeller and inducer surfaces. These results in change in angle of incidence and thus drop in efficiency.

All heavy fuel engines are subjected to heavy load variations which results in fluctuation of exhaust gas pressure. A prolonged fluctuation in pressure leads to detrimental effects on the internal parts of the compressor. For this reason, constant pressure chambers are provided in most of the engines. The exhaust gas, instead of directly entering from the engine, first goes to the pressure chamber and from there it is circulated to the turbine at constant pressure. This reduces the excessive stress that gets created on the shaft bearing and sealing.



**LIMITATIONS-OF TURBO CHARGING**

1. The turbo charging needs special exhaust manifolds
2. Larger pumping elements or nozzles are required to inject more fuel per unit time. This over loads cams and other components.
3. The turbine blade efficiency is very sensitive to gas velocity.
4. It is difficult to maintain satisfactory air charging over the complete operating range of the engine.

**COMPARISON BETWEEN TURBOCHARGING AND MECHANICAL SUPERCHARGING****Turbo Charging**

1. The energy of exhaust gases is used to run super charger
2. It needs a waste gate control
3. It requires special exhaust manifolds
4. In CI engine it reduces smoke
5. Blade erosion takes place due to entry of dust particles
6. Larger pumping elements or nozzles are needed. This over loads cams
7. Pressure ratio is high
8. It is bulky and heavy
9. Easy scavenging
10. Poor response to load change

**Mechanical Super Charging**

1. The mechanical energy of prime mover is used to run super charger
2. It does not require a waste gate control .It does not require special exhaust manifolds
3. In CI engines it reduces knocking tendency
4. No blade erosion problem
5. Fuel injection modification is not required and no cam over loading
6. Comparatively pressure ratio is low
7. It is light and compact
8. Scavenging is difficult
9. Better response to load change

## INTERCOOLER

An intercooler is an integral part of most blown setups. The power that a non-intercooled turbocharger created could be maximized by using an intercooler. An intercooler can be compared to a radiator, yet for intake air, and not coolant fluid.

The intercooler fits on the intake tract to the engine from the supercharger. Generally only centrifugal superchargers (turbochargers included) can be intercooled, due to their mounting options. The intercooler dramatically cools the compressed air, and in effect, packs the air closer together.

V=Volume T=Temperature

$$V_1/T_2 = V_2 /T_1$$

(Given a 2 liters of air at 200°F and an intercooler that cools to 60°F)

What volume of air at can be fit into the same 2 liters that the 200°F air held? 200°F = 366K  
60°F=288K

$$(2L)/ (288K) = (x)/ (366K)$$

$$2.54L = x$$

The intercooler obviously boosts the power of the engine by stuffing more oxygen into the cylinders. The cylinders can therefore create a larger and more vigorous explosion, and therefore produce more power.

Intercoolers can come in two types: air-air, or air-water. Air-air systems use ambient air to directly cool the pressurized air. Air-water systems first cool water with the ambient air around the car, and is then filtered into an internal coolant system, where the cooled water cools the charge-air.

### Turbocharger lag

Turbo lag is a unique phenomenon encountered in turbocharged internal combustion engines, whereby an operator experiences a short delay in full engine response after pressing the accelerator pedal. This occurs because a turbocharger relies on pressure from exhaust gasses, and needs a short amount of time to generate the pressure needed — known as *spooling up*. Turbo lag is considered a negative characteristic in automobiles, and one that engineers strive to mitigate in a number of different ways.

To understand turbo lag, a working knowledge of how turbochargers work and why they are used is helpful. The idea behind adding a turbo system to an engine is to augment the power generated by the engine alone through simple combustion. This basic concept is known as *supercharging*, of which turbo charging is but one variant.

A turbo works by using exhaust air to spin a turbine, which is attached to the same shaft as a compressor. Compressed air created as the turbine spins the compressor is, in turn, fed into the engine. This allows more horsepower to be generated by improving the engine's volumetric efficiency, a trait based in part on the fundamental precept that the more oxygen in a given volume of air, the more potential energy that volume has.

Compared to alternatives like belt-drive superchargers or simply increasing the displacement

of an engine, turbo charging is an attractive option. This is because the proportion of horsepower a turbo creates, as compared to the weight of its parts — a characteristic known as *power to weight ratio* is favorable compared to these other options. Turbo are thus relatively common in gasoline engines, and almost standard in mass-produced diesel engines, which are known as *turbo diesels*. Turbo engines have been particularly embraced by several automobile manufacturers, including Saab®, Mercedes Benz®, and Volkswagen®.

The basic design of a turbocharger consists of a metal — usually aluminum — center housing and hub rotating assembly (CHRA), a turbine, a compressor, and a central shaft. The size of the CHRA, the turbine, and the compressor dictate how much extra horsepower they can generate, and generally also how much turbo lag is going to be created. The larger the parts, the longer the turbo typically takes to spool, and the more turbo lag there will be.

The most common way engineers get around turbo lag is simply to use the lightest components possible, as less inertia means less lag. A more complex way is to pair a large turbo with a smaller one, or with a supercharger. The instant or near-instant spooling of these secondary units helps compensate for the lag, while the larger one builds pressure, minimizing or eliminating it completely.

## UNIT - 4

## IGNITION SYSTEMS

INTRODUCTION

We know that in case of Internal Combustion (IC) engines, combustion of air and fuel takes place inside the engine cylinder and the products of combustion expand to produce reciprocating motion of the piston. This reciprocating motion of the piston is in turn converted into rotary motion of the crank shaft through connecting rod and crank. This rotary motion of the crank shaft is in turn used to drive the generators for generating power. We also know that there are 4-cycles of operations viz.: suction; compression; power generation and exhaust.

These operations are performed either during the 2-strokes of piston or during 4-strokes of the piston and accordingly they are called as 2-stroke cycle engines and 4-stroke cycle engines.

In case of petrol engines during suction operation, charge of air and petrol fuel will be taken in. During compression this charge is compressed by the upward moving piston. And just before the end of compression, the charge of air and petrol fuel will be ignited by means of the spark produced by means of for spark plug. And the ignition system does the function of producing the spark in case of spark ignition engines.

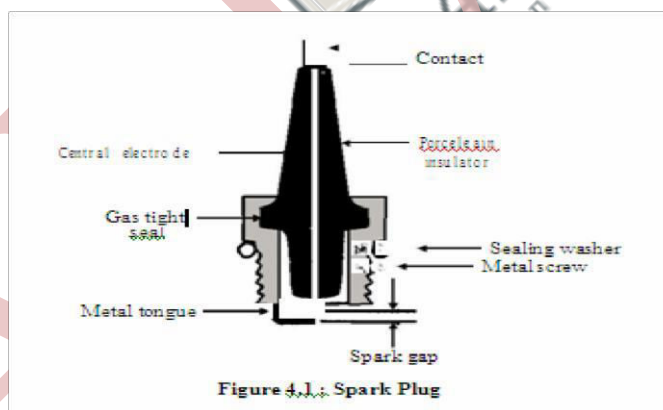


Figure shows atypical spark plug used with petrol engines. It mainly consists of a central electrode and metal tongue. Central electrode is covered by means of porcelain insulating material. Through the metal screw the spark plug is fitted in the cylinder head plug. When the high tension voltage of the order of 30000 volts is applied across the spark electrodes, current jumps from one electrode to another producing a spark.

Whereas in case of diesel (Compression Ignition-CI) engines only air is taken in during suction operation and in compressed during compression operation and just before the end of compression, when diesel fuel is injected, it gets ignited due to heat of compression of air.

Once the charge is ignited, combustion starts and products of combustion expand, i.e. they

force the piston to move downwards i.e. they produce power and after producing the power the gases are exhausted during exhaust operation.

### Objectives

After studying this unit, you should be able to

- Explain the different types of ignition systems,
- Differentiate between battery and magneto ignition system
- Know the drawbacks of conventional ignition system, and
- Appreciate the importance of ignition timing and ignition advance.

### IGNITION SYSTEM TYPES

Basically Convectional Ignition systems are of 2 types :

- (a) Battery or Coil Ignition System, and
- (b) Magneto Ignition System.

Both these conventional, ignition systems work on mutual electromagnetic induction principle.

Battery ignition system was generally used in 4-wheelers, but now-a-days it is more commonly used in 2-wheelers also (i.e. Button start, 2-wheelers like Pulsar, Kinetic Honda; Honda-Activa, Scooty, Fiero, etc.). In this case 6 V or 12 V batteries will supply necessary current in the primary winding. Magneto ignition system is mainly used in 2-wheelers, kick start engines. (Example, Bajaj Scooters, Boxer, Victor, Splendor, Passion, etc.).

In this case magneto will produce and supply current to the primary winding. So in magneto ignition system magneto replaces the battery.

## Battery or Coil Ignition System

Figure shows line diagram of battery ignition system for a 4-cylinder petrol engine. It mainly consists of a 6 or 12 volt battery, ammeter, ignition switch, auto-transformer (step up transformer), contact breaker, capacitor, distributor rotor, distributor contact points, spark plugs, etc. Note that the Figure 4.1 shows the ignition system for 4-cylinder petrol engine, here there are 4-spark plugs and contact breaker cam has 4-corners. (If it is for 6-cylinder engine it will have 6-spark plugs and contact breaker cam will be a perfect hexagon).

The ignition system is divided into 2-circuits:

- 1. Primary Circuit :** It consists of 6 or 12 V battery, ammeter, ignition switch, primary winding it has 200-300 turns of 20 SWG (Sharps Wire Gauge) gauge wire, contact breaker, capacitor.
- 2. Secondary Circuit:** It consists of secondary winding. Secondary winding consists of about 21000 turns of 40 (S WG) gauge wire. Bottom end of which is connected to bottom end of primary and top end of secondary winding is connected to centre of distributor rotor. Distributor rotors rotate and make contacts with contact points and are connected to spark plugs which are fitted in cylinder heads (engine earth).

## WORKING

When the ignition switch is closed and engine is cranked, as soon as the contact breaker closes, a low voltage current will flow through the primary winding. It is also to be noted that the contact breaker cam opens and closes the circuit 4-times (for 4 cylinders) in one revolution. When the contact breaker opens the contact, the magnetic field begins to collapse. Because of this collapsing magnetic field, current will be induced in the secondary winding. And because of more turns (@ 21000 turns) of secondary, voltage goes upto 28000-30000 volts

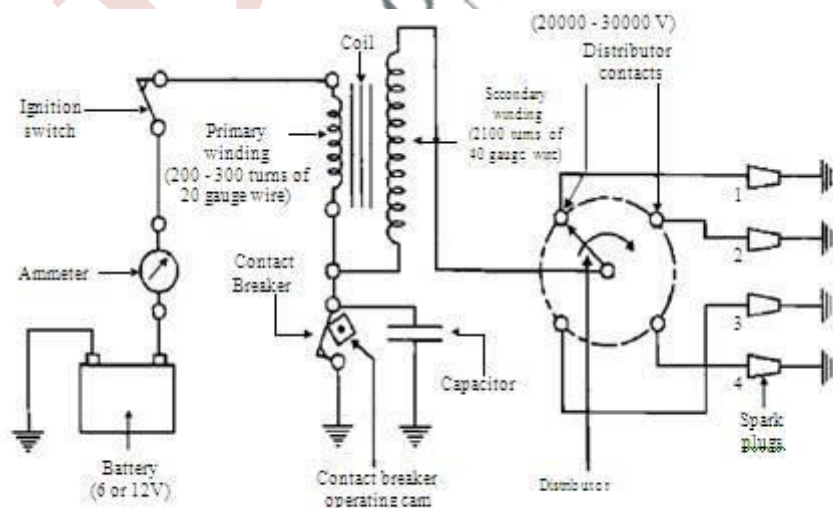


Figure 4.1. Schematic Diagram of Coil/Battery Ignition System

This high voltage current is brought to centre of the distributor rotor. Distributor rotor rotates and supplies this high voltage current to proper spark plug depending upon the engine firing order. When the high voltage current jumps the spark plug gap, it produces the spark and the charge is ignited-combustion starts-products of combustion expand and produce power.

**Note:**

The Function of the capacitor is to reduce arcing at the contact breaker (CB) points. Also when the CB opens the magnetic field in the primary winding begins to collapse. When the magnetic field is collapsing capacitor gets fully charged and then it starts discharging and helps in building up of voltage in secondary winding. Contact breaker cam and distributor rotor are mounted on the same shaft. In 2-stroke cycle engines these are motored at the same engine speed. And in 4-stroke cycle engines they are motored at half the engine speed.

**Magneto Ignition System**

In this case magneto will produce and supply the required current to the primary winding. In this case as shown, we can have rotating magneto with fixed coil or rotating coil with fixed magneto for producing and supplying current to primary, remaining arrangement is same as that of a battery ignition system.

Figure shows the line diagram of magneto ignition system.

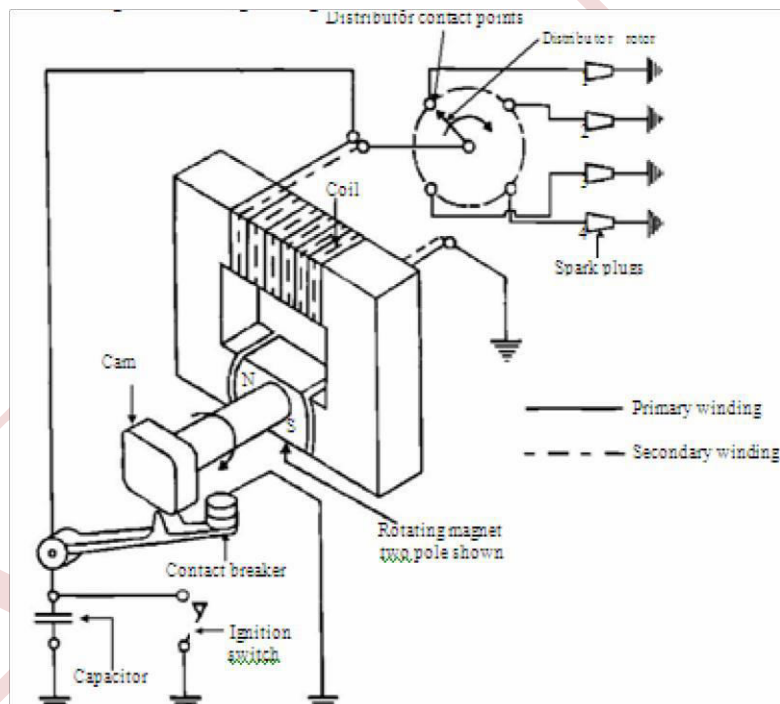


Figure 4.3: Schematic Diagram of Magneto Ignition System

**COMPARISON BETWEEN BATTERY AND MAGNETO IGNITION SYSTEM**

Sl.No	Battery Ignition	Magneto Ignition
1	Battery is a must.	No battery needed.
2	Battery supplies current in primary circuit.	Magneto produces the required current for primary circuit.
3	A good spark is available at low speed also.	During starting the quality of spark is poor due to slow speed.
4	Occupies more space.	Very much compact.
5	Recharging is a must in case battery gets discharged.	No such arrangement required.
6	Mostly employed in car and bus for which it is required to crank the engine.	Used on motorcycles, scooters, etc.
7	Battery maintenance is required.	No battery maintenance problems.

**DRAWBACKS (DISADVANTAGES) OF CONVENTIONAL IGNITION SYSTEMS**

Following are the drawbacks of conventional ignition systems:

1. Because of arcing, pitting of contact breaker point and which will lead to regular maintenance problems.
2. Poor starting: After few thousands of kilometers of running, the timing becomes inaccurate, which results into poor starting (Starting trouble).
3. At very high engine speed, performance is poor because of inertia effects of the moving parts in the system.
4. Sometimes it is not possible to produce spark properly in fouled spark plugs.

In order to overcome these drawbacks Electronic Ignition system is used.

**ADVANTAGES OF ELECTRONIC IGNITION SYSTEM**

Following are the advantages of electronic ignition system:

1. Moving parts are absent-so no maintenance.
2. Contact breaker points are absent-so no arcing.
3. Spark plug life increases by 50% and they can be used for about 60000 km without any problem.
4. Better combustion in combustion chamber, about 90-95% of air fuel mixture is burnt compared with 70-75% with conventional ignition system.
5. More power output.
6. More fuel efficiency.



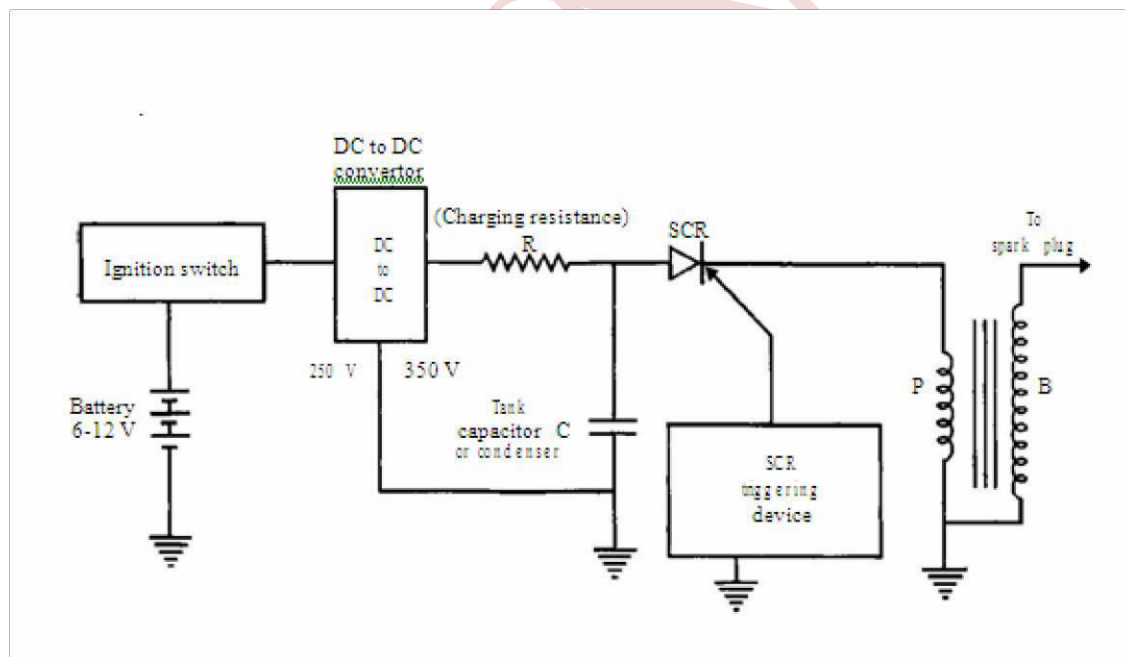
## TYPES OF ELECTRONIC IGNITION SYSTEM

Electronic Ignition System is as follows:

1. Capacitance Discharge Ignition system
2. Transistorized system
3. Piezo-electric Ignition system
4. The Texaco Ignition system

### Capacitance Discharge Ignition System

It mainly consists of 6-12 V battery, ignition switch, DC to DC converter, charging resistance, tank capacitor, Silicon Controlled Rectifier (SCR), SCR-triggering device; step up transformer, spark plugs. A 6-12 volt battery is connected to DC to DC converter i.e., power circuit through the ignition switch, which is designed to give or increase the voltage to 250-350 volts. This high voltage is used to charge the tank capacitor (or condenser) to this voltage through the charging resistance. The charging resistance is also so designed that it controls the required current in the SCR.



**Figure: Capacitance Discharge Ignition System**

Depending upon the engine firing order, whenever the SCR triggering device, sends a pulse, then the current flowing through the primary winding is stopped. And the magnetic field begins to collapse. This collapsing magnetic field will induce or step up high voltage current in the secondary, which while jumping the spark plug gap produces the spark, and the charge of air fuel mixture is ignited.

### Transistorized Assisted Contact (TAC) Ignition System

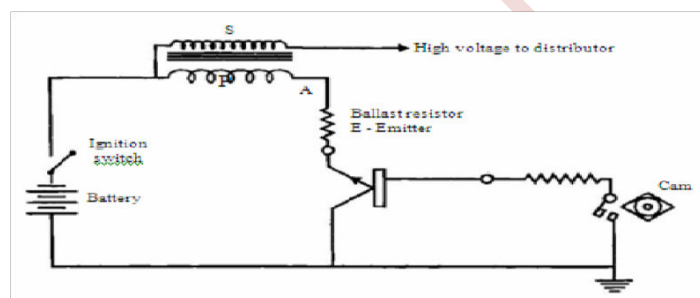
Figure shows the TAC system.

#### Advantages

- The low breaker-current ensures longer life.
- The smaller gap and lighter point assembly increase dwell time minimize contact bouncing and improve repeatability of secondary voltage.
- The low primary inductance reduces primary current drop-off at high speeds.

#### Disadvantages

- As in the conventional system, mechanical breaker points are necessary for timing the spark.
- The cost of the ignition system is increased.
- The voltage rise-time at the spark plug is about the same as before.



**Figure: Transistorized Assisted Contact (TAC) Ignition System**

### Piezo-electric Ignition System

The development of synthetic piezo-electric materials producing about 22 kV by mechanical loading of a small crystal resulted in some ignition systems for single cylinder engines. But due to difficulties of high mechanical loading need of the order of 500 kg timely control and ability to produce sufficient voltage, these systems have not been able to come up.

### The Texaco Ignition System

Due to the increased emphasis on exhaust emission control, there has been a sudden interest in exhaust gas recirculation systems and lean fuel-air mixtures. To avoid the problems of burning of lean mixtures, the Texaco Ignition system has been developed. It provides a spark of controlled duration which means that the spark duration in crank angle degrees can be made constant at all engine speeds. It is a AC system. This system consists of three basic units, a power unit, a control unit and a distributor sensor. This system can give stable ignition up to A/F ratios as high as 24

### FIRING ORDER

The order or sequence in which the firing takes place, in different cylinders of a multi cylinder engine is called Firing Order.

In case of SI engines the distributor connects the spark plugs of different cylinders according to Engine Firing Order.

**Advantages**

- A proper firing order reduces engine vibrations.
  - Maintains engine balancing.
  - Secures an even flow of power.
1. 3 cylinder = 1-3-2
  2. 4 cylinder engine (inline) = 1-3-4-2, 1-2-4-3
  3. 4 cylinder horizontal opposed engine = 1-4-3-2 (Volkswagen engine)
  4. 6-cylinder in line engine = 1-5-3-6-2-4 (Crank in 3 pairs) 1-4-2-6-3-5, 1-3-2-6-4-5,
    - i. 1-2-4-6-5-3
  5. 8 cylinder in line engine = 1-6-2-5-8-3-7-4, 1-4-7-3-8-5-2-6
  6. 8 cylinder V type 1-5-4-8-6-3-7-2, 1-5-4-2-6-3-7-8, 1-6-2-5-8-3-7-4, 1-8-4-3-6-5-7-2

Cylinder 1 is taken from front of inline and front right side in V engines

**IMPORTANCE OF IGNITION TIMING AND IGNITION ADVANCE**

Ignition timing is very important, since the charge is to be ignited just before (few degrees before TDC) the end of compression, since when the charge is ignited, it will take some time to come to the required rate of burning.

**Ignition Advance**

The purpose of spark advance mechanism is to assure that under every condition of engine operation, ignition takes place at the most favorable instant in time i.e. most favorable from a standpoint of engine power, fuel economy and minimum exhaust dilution. By means of these mechanisms the advance angle is accurately set so that ignition occurs before TDC point of the piston. The engine speed and the engine load are the control quantities required for the automatic adjustment of the ignition timing. Most of the engines are fitted with mechanisms which are integral with the distributor and automatically regulate the optimum spark advance to account for change of speed and load. The two mechanisms used are :

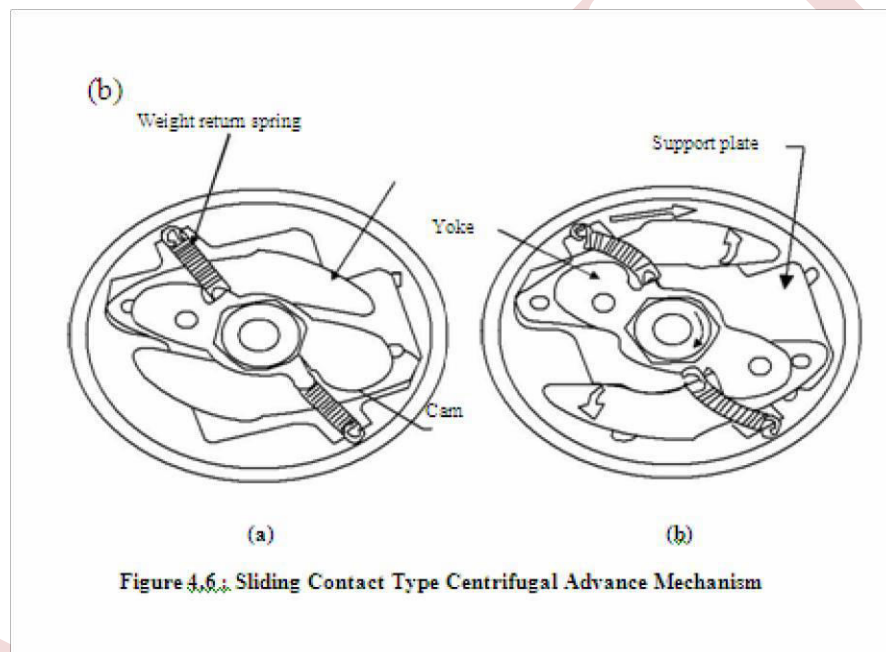
- (a) Centrifugal advance mechanism, and
- (b) Vacuum advance mechanism.

**Centrifugal Advance Mechanism**

The centrifugal advance mechanism controls the ignition timing for full- load operation. The adjustment mechanism is designed so that its operation results in the desired advance of the spark. The cam is mounted, movably, on the distributor shaft so that as the speed increases, the flyweights which are swung farther and farther outward, shaft the cam in the direction of shaft rotation. As a result, the cam lobes make contact with the breaker lever rubbing block somewhat earlier, thus shifting the ignition point in the early or advance direction. Depending on the speed of the engine,

and therefore of the shaft, the weights are swung outward a greater or a lesser distance from the center. They are then held in the extended position, in a state of equilibrium corresponding to the shifted timing angle, by a retaining spring which exactly balances the centrifugal force. The weights shift the cam either on a rolling contact or sliding contact basis; for this reason we distinguish between the rolling contact type and the sliding contact type of centrifugal advance mechanism.

The beginning of the timing adjustment in the range of low engine speeds and the continuous adjustment based on the full load curve are determined by the size of the weights by the shape of the contact mechanisms (rolling or sliding contact type), and by the retaining springs, all of which can be widely differing designs. The centrifugal force controlled cam is fitted with a lower limit stop for purposes of setting the beginning of the adjustment, and also with an upper limit stop to restrict the greatest possible full load adjustment. A typical sliding contact type centrifugal advance mechanism is shown in Figures 4.6(a) and (b).



### Vacuum Advance Mechanism

Vacuum advance mechanism shifts the ignition point under partial load operation. The adjustment system is designed so that its operation results in the prescribed partial load advance curve. In this mechanism the adjustment control quantity is the static vacuum prevailing in the carburetor, a pressure which depends on the position of the throttle valve at any given time and which is at a maximum when this valve is about half open. This explains the vacuum maximum. The diaphragm of a vacuum unit is moved by changes in gas pressure. The position of this diaphragm is determined by the pressure differential at any given moment between the prevailing vacuum and atmospheric pressure. The beginning of adjustment is set by the pre-established tension on a compression spring. The diaphragm area, the spring force, and the spring rigidity are all selected in accordance with the partial – load advance curve which is to be followed and are all balanced with respect to each other. The diaphragm movement is transmitted through a vacuum advance arm connected to the movable breaker plate, and this movement shifts the breaker plate an additional

amount under partial load condition in a direction opposite to the direction of rotation of the distributor shaft. Limit stops on the vacuum advance arm in the base of the vacuum unit restrict the range of adjustment. The vacuum advance mechanism operates independent of the centrifugal advance mechanism. The mechanical interplay between the two advance mechanisms, however, permits the total adjustment angle at any given time to be the result of the addition of the shifts provided by the two individual mechanisms operates in conjunction with the engine is operating under partial load.

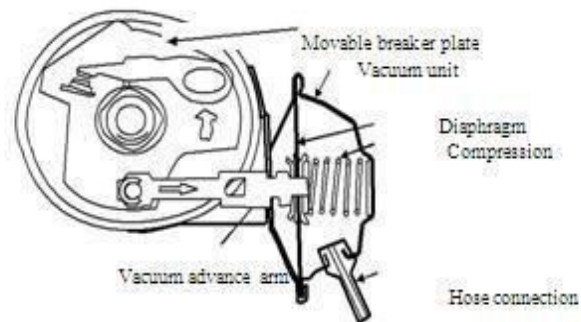


Figure 4.7: Vacuum Advance Mechanism

**UNIT - 5****POWER TRAINS****INTRODUCTION**

A Transmission system uses a clutch, gear box, propeller shaft and a differential gear to transmit power from engine to the road wheels. The power may be transmitted to rear or front wheels or all the four wheels, depending on the type of drive used in automotive. The clutch and gear box varies the leverage i.e. ratio of torque output to torque input. The propeller shaft transmits final torque to the rear axle from gear box, and a differential gear equally distributes the final torque between the road wheels (driving wheels).

A Transmission system has to perform following functions.

1. It disconnects engine from driving wheels when required.
2. The engine is connected to driving wheels without jerk.
3. It changes ratio of torque output to torque input, as desired.
4. It turns the drive through a right angle.

**CLUTCH**

Clutch is a device used in the transmission system of a motor vehicle to engage and disengage the engine to the transmission. Thus the clutch is located between the engine and the transmission. Typically a clutch consists of clutch fork, thrust bearing, diaphragm, cover, pressure plate, clutch plate, and a flywheel

*Functions of a clutch are as follows,*

- When the clutch is engaged, the power flows from the engine to the rear wheels through the transmission system and the vehicle moves.
- When the clutch is disengaged, the power is not transmitted to the rear wheels and the vehicles stops while the engine is still running.
- The clutch is disengaged when starting the engine, when shifting the gears, when stopping the vehicle and when idling the engine. The clutch is kept engaged when the vehicle is moving.
- The clutch also permits the gradual taking up of the load. When properly operated, it prevents jerky motion of the vehicle.

**The various design requirements of a clutch are as follows:**

1. **Torque Transmission:** The clutch should be able to transmit maximum torque of the engine.
2. **Gradual Engagement:** The clutch should engage gradually to avoid sudden jerks.
3. **Heat Dissipation:** The clutch should be able to dissipate large amount of heat which is

generated during the clutch operation due to friction.

4. **Dynamic Balancing:** The clutch should be dynamically balanced.
5. **Vibration Damping:** The clutch should have suitable mechanism to damp vibrations and to eliminate noise produced during the power transmission.
6. **Clutch Size:** The clutch should be as small as possible in size so that it will occupy minimum space.
7. **Free Pedal Play:** The clutch should have free pedal play in order to reduce effective clamping load on the thrust bearing and wear on it.
8. **Easy in Operation:** The clutch should be easy to operate requiring as little exertion as possible on the part of the driver.
9. **Lightness:** The driven member of the clutch should be made as light as possible so that it will not continue to rotate for any length of time after the clutch has been disengaged.

### FRICITION CLUTCHES AND FLUID FLYWHEEL

Clutches are mainly classified into.

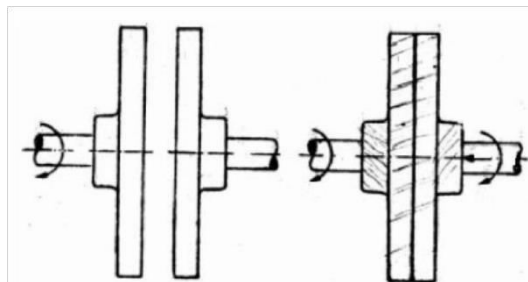
1. Friction Clutches
2. Fluid Fly Wheel.

Friction Clutches are again made in dry and wet type. In this type, the transmission of power is caused due to friction between two rotating members. However, in the wet type, coefficient of friction is less. A fluid fly wheel causes energy transfer between two members due to movement of fluid.

### PRINCIPLE (OPERATION) OF FRICTION CLUTCHES

The clutch works on the principle of friction. When two friction surfaces are brought in contacts with each other and pressed they are united due to the friction between them. If one revolves, the other will also revolve. The friction between the two surfaces depends upon the area of the surfaces, pressure applied upon them and coefficient of friction of the surface materials. The two surfaces can be separated and brought into contact when required.

One surface is considered as driving member and the other as driven member, the driving member is kept rotating. When the driven member is brought in contact with the driving member, it also starts rotating. When the driven member, it also starts rotating. When the driven member is separated from the driving member it does not revolve.



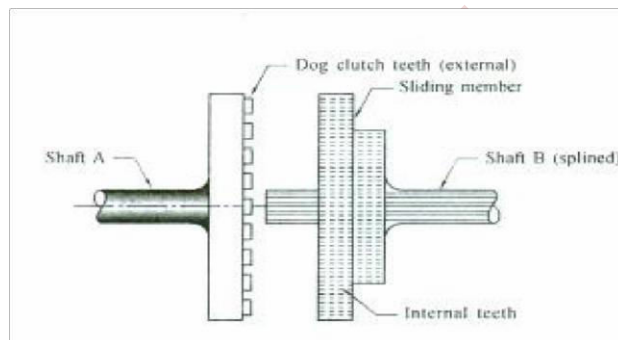
**Fig: Friction clutches**

**Dog Clutches**

A dog clutch is a type of clutch that couples two rotating shafts or other rotating components not by friction but by interference. The two parts of the clutch are designed such that one will push the other, causing both to rotate at the same speed and will never slip.

Dog clutches are used where slip is undesirable and/or the clutch is not used to control torque. Without slippage, dog clutches are not affected by wear in the same way that friction clutches are. Dog clutches are used inside manual automotive transmissions to lock different gears to the rotating input and output shafts. A synchromesh arrangement ensures smooth engagement by matching the shaft speeds before the dog clutch is allowed to engage.

A good example of a simple dog clutch can be found in a Sturmey-Archer bicycle hub gear, where a sliding cross-shaped clutch is used to lock the driver assembly to different parts of the planetary gear train.

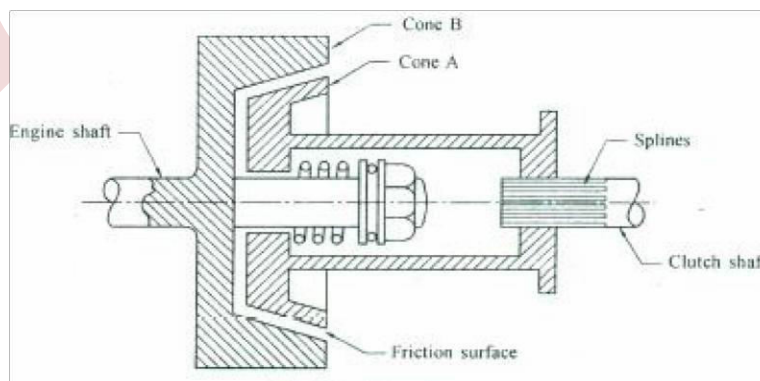


**Fig. Dog Clutch**

A cone clutch serves the same purpose as a disk or plate clutch. However, instead of mating two spinning disks, the cone clutch uses two conical surfaces to transmit torque by friction.

The cone clutch transfers a higher torque than plate or disk clutches of the same size due to the wedging action and increased surface area. Cone clutches are generally now only used in low peripheral speed applications although they were once common in automobiles and other combustion engine transmissions.

They are usually now confined to very specialist transmissions in racing, rallying, or in extreme off-road vehicles, although they are common in power boats. This is because the clutch does not have to be pushed in all the way and the gears will be changed quicker. Small cone clutches are used in synchronizer mechanisms in manual transmissions.



**Fig: Cone clutch**



### Advantages

1. When compared to single plate clutch, the normal force on friction surfaces is greater than axial force.

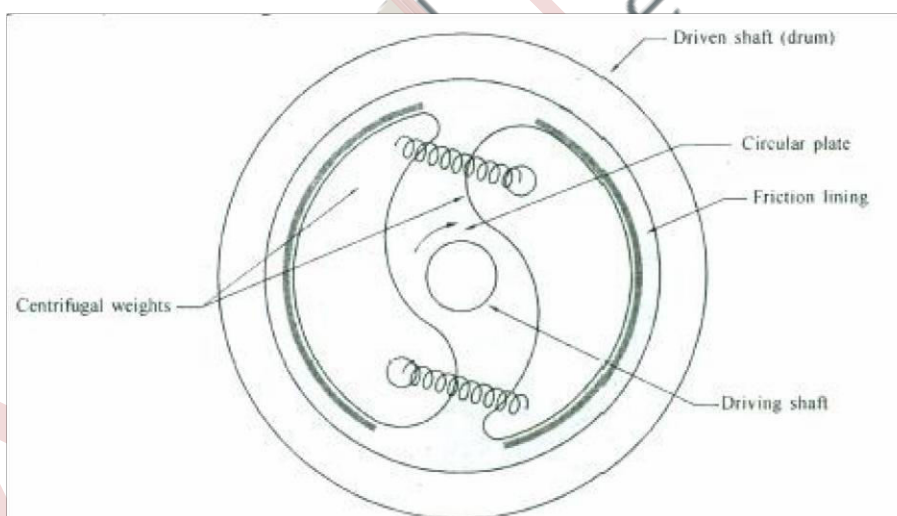
### Disadvantages

- a. It is difficult to disengage the clutch if cone angle is less than  $20^\circ$ , as one cone tends to bind in the other.
- b. Even a small amount of wear on friction surface results in more axial movement of the cones

### Centrifugal clutch

Centrifugal clutch is an automatic clutch which is controlled by the engine speed through the accelerator. When the engine speed increases above the certain limit, the clutch engages and when the engine speed decreases, the clutch disengages automatically.

This type of clutch design essentially consists of two members. One is the driving member which is fitted on the driving shaft. The other one is a driven member, which is just a drum and encloses the driving member. The driving member consists of two curved shoes or flyweights having frictional linings on them. The shoes are anchored at one end to the back plate and are kept in position by means of coil springs.



**Fig. Centrifugal Clutch**

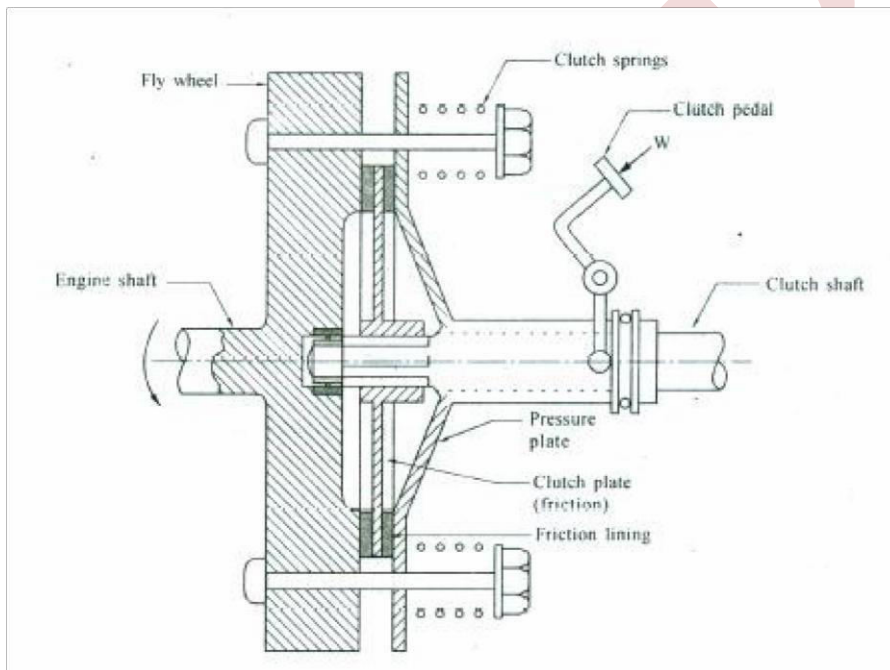
**Operation of centrifugal clutch:** The driving member rotates along with the engine shaft. When the engine speed increases, the centrifugal force also increases. At certain engine speed the shoes fly outwards due to increased centrifugal force and they come in contact with the driven member. Now both driving and driven members rotate together and the clutch is said to be engaged.

When the engine speed decreases, the centrifugal force also decreases. Now, the shoes return back to their original position due to spring force, which results in a disengagement of clutch.

This type of clutch is used in mopeds.

**Single Plate Clutch:**

A single disc or plate clutch consists of a clutch plate whose both sides are faced with a frictional material. It is mounted on the hub which is free to move axially along the splines of the driven shaft. The pressure plate is mounted inside the clutch body which is bolted to the flywheel. Both the pressure plate and the flywheel rotate with the engine crank shaft or the driving shaft. The pressure plate pushes the clutch plate towards the flywheel by a set of strong springs which are arranged radially inside the body. The three levers (also known as release levers or fingers) are carried on pivots suspended from the case of the body. These are arranged in such a manner so that the pressure plate moves away from the flywheel by the inward movement of a thrust bearing. The bearing is mounted upon a forked shaft and moves forward when the clutch pedal is pressed



**Fig: Single Plate Clutch**

When the clutch pedal is pressed down, its linkage forces the thrust release bearing to move in towards the flywheel and pressing the longer ends of the levers inward.

The axial pressure exerted by the spring provides a frictional force in the circumferential direction when the relative motion between the driving and driven members tends to take place. If the torque due to this frictional force exceeds the torque to be transmitted, then no slipping takes place and the power is transmitted from the driving shaft to the driven shaft.

**Advantages**

1. Pedal movement is less and hence gear changing is easier.
2. It is more reliable. [No problem of cone binding etc.].

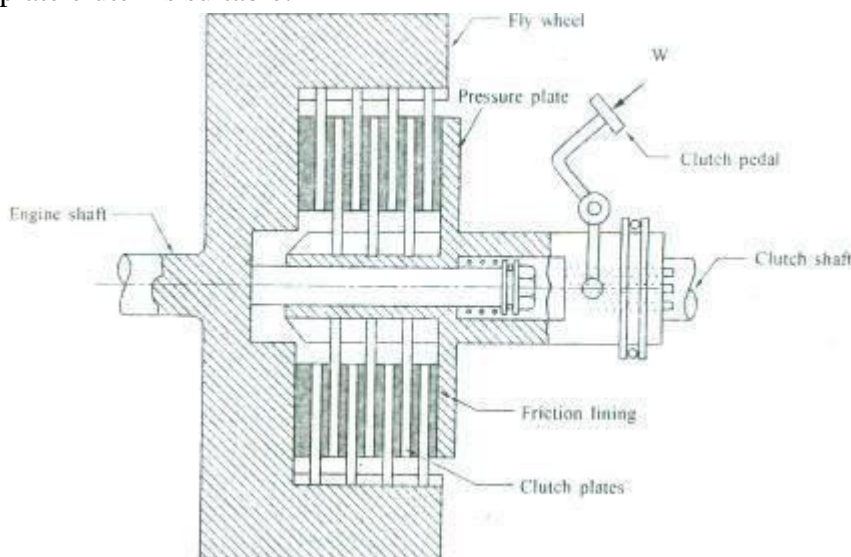
**Disadvantages**

1. The spring stiffness required is more, hence greater force is required for disengaging the clutch.

**Multi plate Clutch:**

A multi-plate clutch has more than one driven plate. Although this type of clutch has been widely used on cars up to about 1930, the several advantages of the single-plate clutch, specifically its ability to completely disengage the drive has caused a very rare use of a multiplate unit as a main transmission clutch installed between the engine and gear box.

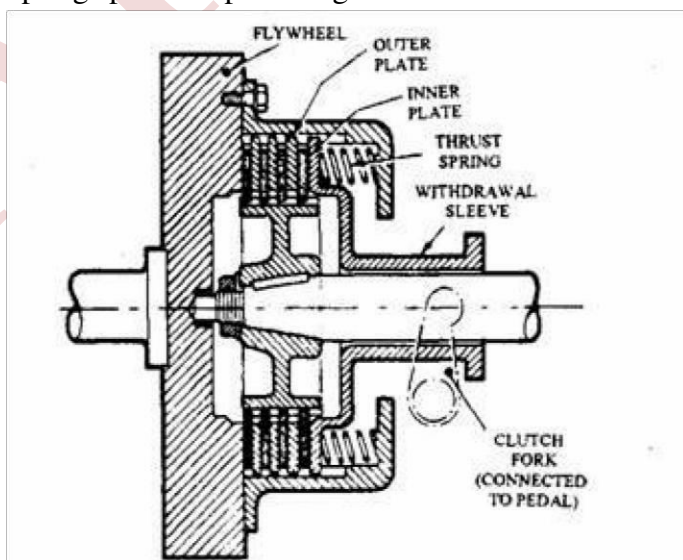
However, a multi-plate type of clutch finds a use in automatic gearboxes. In these gearboxes, a number of clutches hold the various gear elements, and as the clutch diameter in these units is limited, a multi-plate clutch is suitable.



**Fig: Multi-plate clutch**

**Multi-plate Spring Type Clutch**

Figure illustrates the layout of a multi-plate spring type clutch, fitted on early motor cars. A cover, bolted to the flywheel, engages by means of slots with a series of lugs on the outer plates. These steel plates may be plain or fitted with cork or friction material inserts and acts on inner plates, splined to a hub. Thrust springs push the plates together to form a drive.



**Fig: Multi-plate spring type clutch.**

For the clutch disengagement, the end plate is withdrawn to compress the springs and release the other plates. In this arrangement it is difficult to ensure the disengagement of all plates.

To overcome this problem the plates are either dished or fitted with small springs to push the plates apart.

Generally wet type clutch is used in automatic gearboxes, and is operated by a piston governed by hydraulic pressure. Sintered bronze plates of partially fusing powdered bronze or compressed paper are used in many designs. The porous surface of this plate traps the oil, to provide long life and smooth operation.

**TRANSMISSION**

The engine would have power, enough to operate a vehicle without a transmission, provided the vehicle operated on reasonably level roads and maintained sufficient speed. When the vehicle must be started from a standstill or when attempting to negotiate steep grader, the engine would not provide sufficient power and the vehicle would stall. Much less torque is required to move the vehicle on level ground than to drive the same vehicle up on a steep hill. To enable the engine to increase the torque to the drive line, a torque multiplier (transmission) is needed.

Different types of semiautomatic and automatic transmissions are used in recent years. As discussed early, transmission is the mechanism which transmits power from engine to the road wheels. From here onwards transmission is used in the sense that, a mechanism which provides suitable variation of the engine torque at the road wheels. This may be a gear box or manual transmission or an automatic transmission.

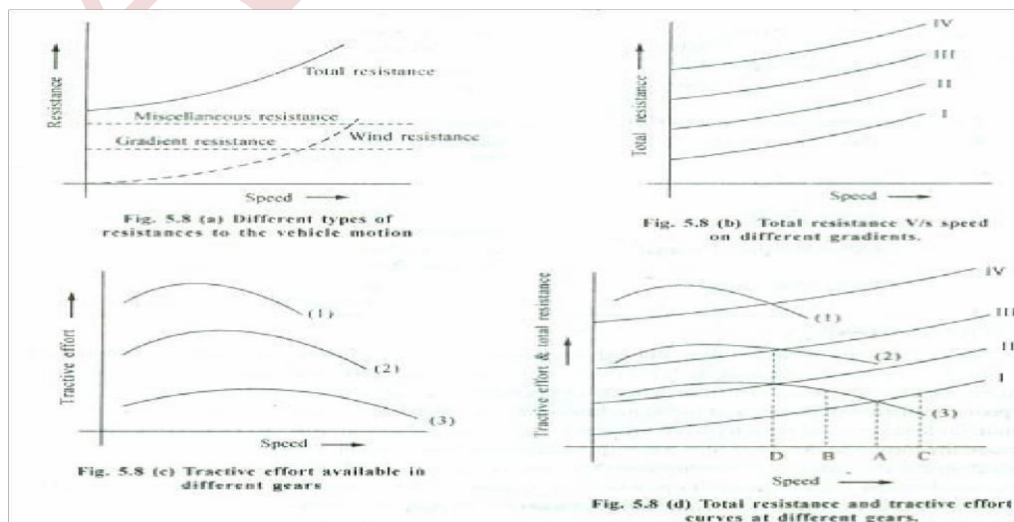
**NECESSITY FOR GEAR RATIOS IN TRANSMISSION**

The Necessity for gear ratios in a vehicle can be explained by considering,

1. Variation of resistance to the vehicle motion at different speeds.
2. Variation of tractive effort of the vehicle available at different speeds.

Total resistance to the motion of vehicle, this includes

1. **Wind resistance:** It is directly proportional to the square of vehicle speed.
2. **Gradient resistance:** At all vehicle speeds, this remains constant.
3. **Other resistances:** The miscellaneous factors contribute to the vehicle resistance are types of road, tyre friction etc. All these are assumed to be constant, irrespective of vehicle speed. The figure (a) shows variation of different types of resistances with speed.



For a particular type of road, the variation of total resistance on different gradients is as shown in fig. (b).

The fig (c) shows tractive effort (torques) available in different gears. It is clear that high torque is available in the low gear.

The fig. (d) Shows superimposition of total resistance and tractive effort curves for different gears.

Let us consider the vehicle is moving on a gradient for which total resistance curve is I. Let the vehicle be in the top gear and the curve 3 shows the available torque in the top gear. The intersection of curves I and 3 gives the stabilizing speed 'OA'. At any instant, if the vehicle speed decreases to say 'O8', the excess of tractive effort will accelerate it to speed 'OA'. Similarly if the speed increases to 'OC', the excess of resistance will decelerate the speed to 'OA'. So when the tractive effort over comes the total resistance, the vehicle speed increases such that the tractive effort becomes equal to the total resistance.

Suppose if the vehicles move on a steeper gradient than curve I, the stabilizing speed decreases to '00'.

Suppose, if we consider curve III, no where it crosses curve 3 (top gear). This means vehicle will not move on the gradient with the top gear. We have to pass on to second gear to get stabilizing speed '00'. Similarly on gradient IV, we have to shift to first gear.

During starting, more acceleration is required to gain speed quickly. In the first gear, torque available is maximum and hence during starting, we have to shift to first gear to gain speed quickly. Once the necessary speed has attained, the vehicle speed has to be simply maintained and acceleration is not required. We may shift into higher gears where less torque is available.

### Types of Transmission system

The automobile transmission system can be classified into two types including manual and automatic transmission. In case of the manual transmission system, the vehicle is driven with the assistance of gearshift and foot clutch. The other components, which are used in this process, are flywheel, pressure plate and ring gears.

In case of the automatic transmission system, the gears are changed automatically corresponding with the vehicle's speed. The basic components essential for this process are modulator, torque converter, planetary gears, governor, computer, seals and hydraulic designs.

### MANUAL TRANSMISSION

All manual transmission has a reverted gear train which consists of an input (clutch shaft) and output shaft (main shaft) whose axes are in the same line. A lay shaft (counter shaft) is located directly below these shafts. From the clutch disc, engine power goes in to the transmission through the input shaft (clutch shaft). In direct drive, clutch shaft is coupled to the main shaft, so that power transmission takes place directly between them. In reduction, power goes to lay shaft and then reverts back to the main shaft.

#### Manual transmission

Sliding mesh gear box Constant mesh gear box Synchronesh gear box (3, 4 and 5 speed)

In sliding mesh type, all the gears on the lay shaft are fixed. All the time they are rotating when the

engine is running and clutch is engaged. The gears on the main shaft are free to slide on the splines. Different gear ratios can be obtained by moving the main shaft gears to the left or right by means of selector mechanism. This gear box gives 3-direct and 1-reverse speeds.

In constant mesh type, all the gears on the main shaft and layshaft are in constant mesh with each other. The lay shaft gears are fixed to it as usual and main shaft gears are free on the splines of the main shaft. The two dog clutches are moved either to the left or to the right to get different gear ratios.

### SYNCHROMESH GEAR BOX

This gear box is similar to constant mesh type i.e. all the gears on the main shaft and lay shaft are in constant mesh with each other. The gears on the main shaft are free to rotate and gears on the lay shaft are fixed to it. It is obvious that for one gear to mesh with another quietly and without damage, they must have to rotate at nearly the same speed. In constant mesh type, the dog clutches to engage smoothly, the speed of main shaft gear and the dog which is sliding must be equal. Therefore, for obtaining lower gear, speed of clutch shaft, lay shaft and main shaft gear must be increased and is accomplished by double declutching.

Double declutching procedure is as follows,

- Disengage the clutch and brought the gear to neutral position.
- Engage the clutch and increase the speed of main shaft gears by operating accelerator pedal.
- Disengage the clutch and put the required lower gear.
- Engage the clutch.

As the clutch is disengaged twice, this process is called double declutching.

For obtaining higher gear, we have to go in the reverse manner. For smooth engagement of tile gear, we have to wait with neutral gear till the main shaft speed is decreased sufficiently.

But most of the transrnissions are equipped with a synchronizer to avoid the process of double declutching. The members to be engaged are first brought into frictional contact. This makes their speed equal, and then the members may be engaged smoothly. However, these devices are not fitted to all the gears; they are used only on higher gears. Dog clutches are used on low and reverse gears to reduce the cost.

The typical diagram of a synchronizer is as shown in figure.

The fig. shows the simplified view of a synchronizer which is used on the higher gear side.

The sliding hub 'C' is free to slide on the splines of the main shaft. A ring member 'D' having internal teeth fit on to the external teeth of sliding hub 'C'. 'H' is a dog teeth on the clutch gear 'B' and these also fit on to the teeth of 'D'. 'E' is the fork fitted on 'D'; 'G' is the ball supported by spring and prevents sliding of 'D' on 'C'. When axial force applied on 'D' through 'E', exceeds certain value, the balls are over come and 'D' slides over 'C'.  $F_1$ ,  $F_2$ ' are the friction surfaces.

To obtain direct gear ring member (D) and hence sliding hub (C) is slid towards left till friction surfaces F1 and F2 rub against each other and friction makes their speed equal. Further pushing of 'D', towards left causes the ring member to override the balls and gets engaged with dog 'H' and provides direct drive from gear B via 'C' and the splines. Similarly second gear is obtained by sliding the sliding hub 'C' to the right.

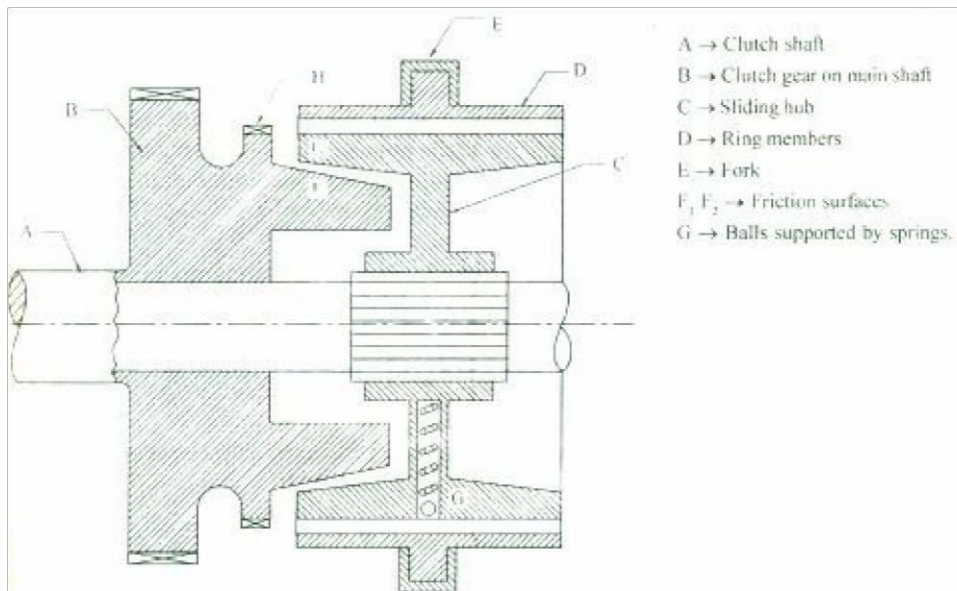


Fig. 5.9 Synchromesh device on higher gear side in a gear box.

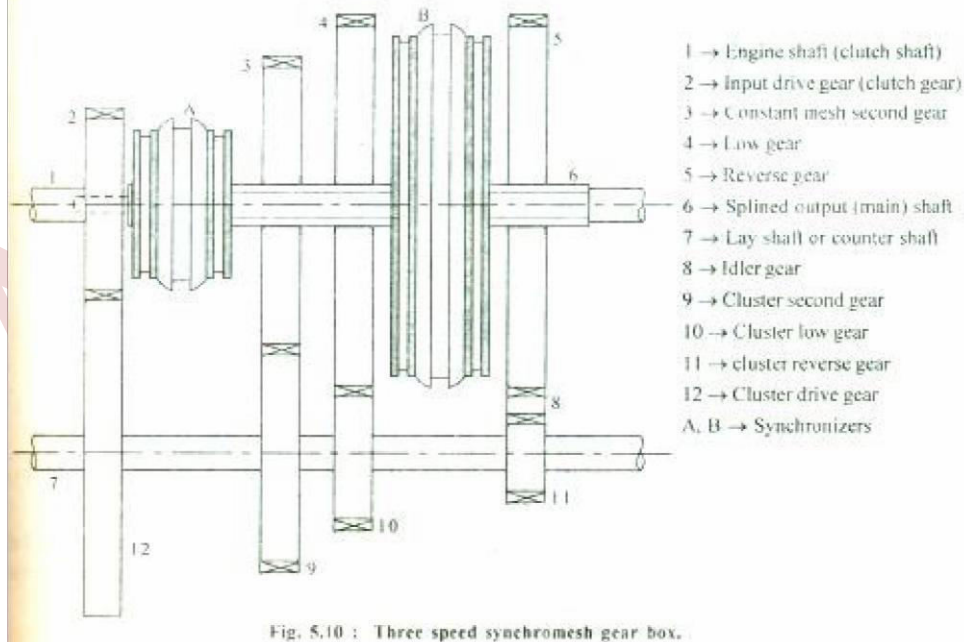


Fig. 5.10 : Three speed synchromesh gear box.

### THREE SPEED SYNCHROMESH TRANSMISSION

In this type, all the gears on the main shaft are in constant mesh with the corresponding gears on the counter shaft. The main shaft gears are free to rotate, while counter shaft gears are fixed to it. Since all the gears are in constant mesh, the gears on the input (clutch) shaft, main shaft (output

shaft) and counter shaft are always rotating with the running condition of engine i.e., when the clutch gear is rotating. The figure shows a fully synchronized transmission, with all forward speeds having synchronizing devices. The different gear ratios are obtained as follows:

**Low Gear (First Gear)**

Low gear is obtained by moving the synchronizer '8' to the left and synchronizer 'A' is still in the neutral position. A friction surface rubs against each other and the friction makes their speed equal. Further pushing of synchronizer '8', causes it to mesh with teeth of low gear (No. 4) and the drive is transmitted through 1-2-12-10-4-8-6 (input shaft - gear 2, 12, 10,4 - Synchronizer '8' through the splines to the output shaft) and low gear is obtained.

**Second Gear**

When the synchronizer 'A' slid to the right it meshes with gear 3 and second gear is obtained. The drive is transmitted through 1-2-12-9-3-A-6 [8 is in neutral].

**Third (High) Gear [Direct Gear]**

When the synchronizer 'A' slid towards left with '8' is in neutral, it meshes with teeth of gear 2. This locks the input and output shaft together and the power flow is direct. The cluster is driven and still turns the second gear which is free to turn on the output shaft.

**Reverse Gear**

Reverse gear is obtained by moving synchronizer '8' to the right with 'A' in the neutral position. The input shaft turns the cluster which in turn drives the gear '5' through 'II' and '8'.

The idler gear '8', changes the direction of rotation of input shaft [1-2-12-11-8-5-6].

**SYNCHROMESH GEAR BOX (4 SPEED)**

The figure shows four forward and one reverse speed transmission. It contains additional gearing to provide for the fourth speed. All forward gears are synchronized.

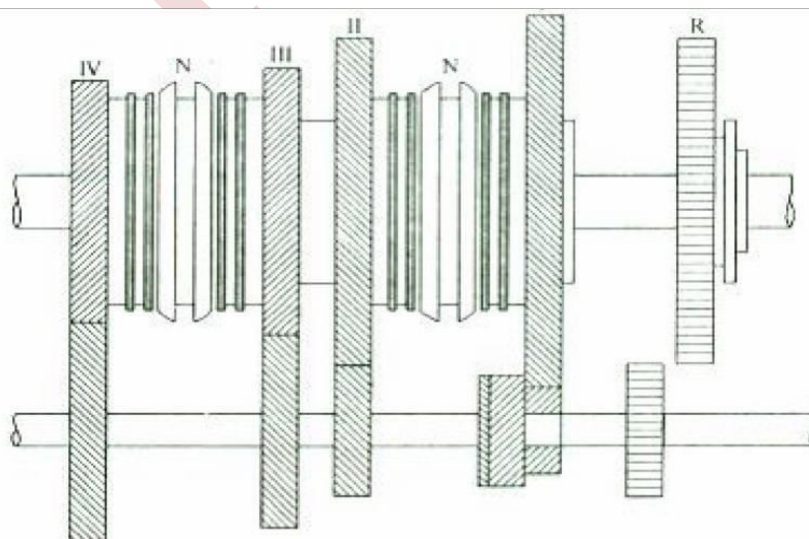


Fig. 5.11 : Four speed transmission with all forward speed synchronised



Gear teeth are helical cut, with the exception of the reverse sliding gear and rear reverse idler gear. Figure (a) to (e) shows gear drive positions for various speeds.

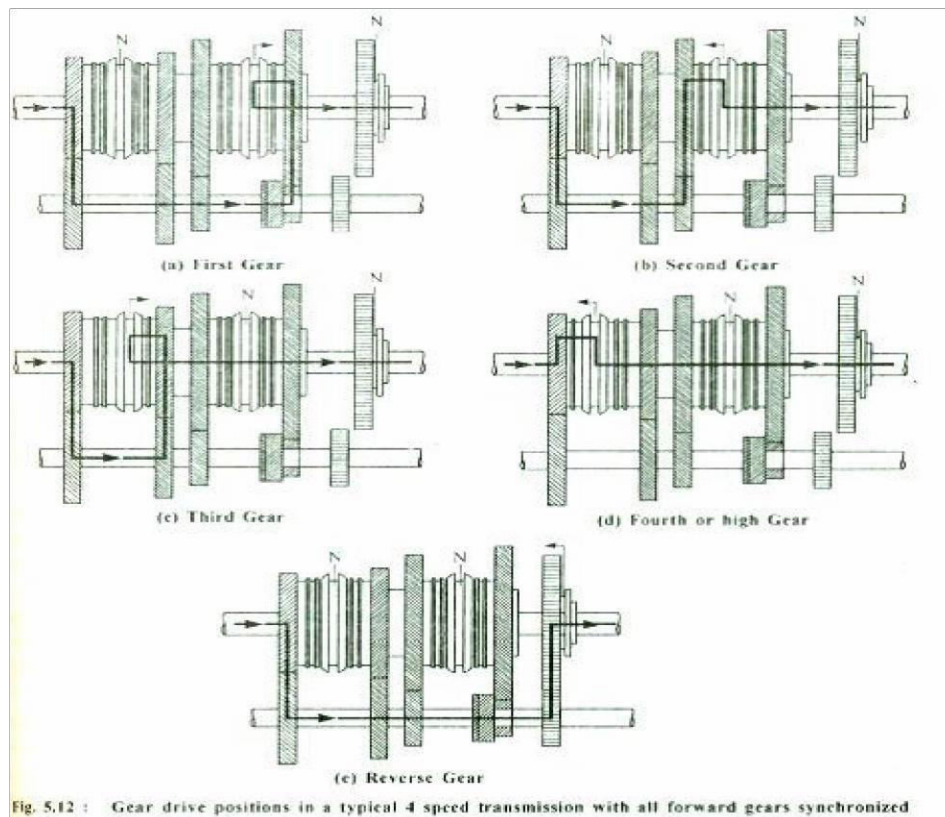


Fig. 5.12 : Gear drive positions in a typical 4 speed transmission with all forward gears synchronized

## OVER DRIVE

When the standard transmission has been shifted into high gear, the ratio between the clutch shaft and the transmission main shaft is 1:1. The unit over drive is located on the back of transmission, between the transmission and the propeller shaft, provides a speed ratio over that of direct or high speed ratio. The over drive allows the engine to operate at only about 70% of the propeller shaft speed, when the vehicle is running at higher speeds.

Over drive mechanism is special equipment, causes the main shaft to over drive or turn more rapidly than the clutch shaft. When the over drive is put into operation, it drops (decreases) the engine speed by about 30 percent without changing vehicle speed. Suppose if a vehicle runs 40 kmph. in direct gear with an engine rpm of 2000 rpm, the use of over drive would decrease the engine speed to 1400 rpm without changing the vehicle speed. (It maintains 40 kmph. vehicle speeds). Essentially, the over drive consists of a planetary gear system and a freewheeling mechanism.

## Overdrive

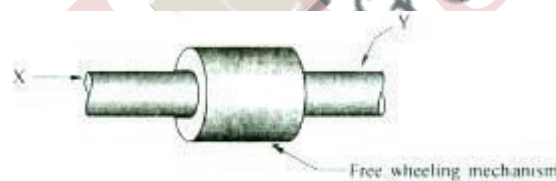
Overdrive is the highest gear in the transmission. Overdrive allows the engine to operate at a lower RPM for a given road speed. This allows the vehicle to achieve better fuel efficiency, and often quieter operation on the highway. When it is switched on, an automatic transmission can shift into overdrive mode after a certain speed is reached (usually 70+ km/h depending on the load). When

it is off, the automatic transmission shifting is limited to the lower gears. For an automatic transmission, it is almost always best to select overdrive and allow the transmission to control engagement of the overdrive. (It may be necessary to switch it off if the vehicle is being operated in a mountainous area, carrying a heavy load, or when the driver wishes to intentionally keep the engine running at higher RPM for quicker acceleration). With a manual transmission, overdrive should usually be selected when the average speed is above 70 km/h (40-45 mph).

The automatic transmission automatically shifts from OD to direct drive when more load is present. When less load is present, it shifts back to OD. Under certain conditions, for example driving uphill, or towing a trailer, the transmission may "hunt" between OD and the next highest gear, shifting back and forth. In this case, switching it off can help the transmission to "decide". It may also be advantageous to switch it off if engine braking is desired, for example when driving downhill. The vehicle's owner's manual will often contain information and suitable procedures regarding such situations, for each given vehicle.

### Roller Clutch or Free Wheeling Mechanism

A special form of a ratchet is the overrunning clutch. Have you ever thought about what kind of mechanism drives the rear axle of bicycle? It is a free-wheel mechanism which is an overrunning clutch. Figure 8-2 illustrates a simplified model. As the driver delivers torque to the driven member, the rollers or balls are wedged into the tapered recesses. This is what gives the positive drive. Should the driven member attempt to drive the driver in the directions shown, the rollers or balls become free and no torque is transmitted.



**Fig. Freewheeling mechanism**

In mechanical or automotive engineering, a freewheel or overrunning clutch is a device in a transmission that disengages the driveshaft from the driven shaft when the driven shaft rotates faster than the driveshaft. An overdrive is sometimes mistakenly called freewheel, but is otherwise unrelated.

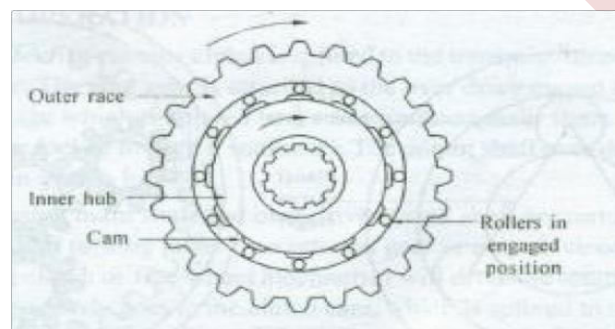
The condition of a driven shaft spinning faster than its driveshaft exists in most bicycles when the rider holds his or her feet still, no longer pushing the pedals. In a fixed-gear bicycle, without freewheel; the rear wheel would drive the pedals around.

The simplest freewheel device consists of two saw-toothed, spring-loaded discs pressing against each other with the toothed sides together, somewhat like a ratchet. Rotating in one direction, the saw teeth of the drive disc lock with the teeth of the driven disc, making it rotate at the same speed. If the drive disc slows down or stops rotating, the teeth of the driven disc slip over the drive disc teeth and continue rotating, producing a characteristic clicking sound proportionate to the speed difference of the driven gear relative to that of the (slower) driving gear.

A more sophisticated and rugged design has spring-loaded steel rollers inside a driven cylinder. Rotating in one direction, the rollers lock with the cylinder making it rotate in unison. Rotating slower, or in the other direction, the steel rollers just slip inside the cylinder.

a freewheel mechanism acts as an automatic clutch, making it possible to change gears in a manual gearbox, either up- or downshifting, without depressing the clutch pedal, limiting the use of the manual clutch to starting from standstill or stopping. The Saab freewheel can be engaged or disengaged by the driver by respectively pushing or pulling a lever. This will lock or unlock the main shaft with the freewheel hub.

A freewheel also produces slightly better fuel economy on carbureted engines (without fuel turn-off on engine brake) and less wear on the manual clutch, but leads to more wear on the brakes as there is no longer any ability to perform engine braking. This may make freewheel transmissions dangerous for use on trucks and automobiles driven in mountainous regions, as prolonged and continuous application of brakes to limit vehicle speed soon leads to brake- system overheating followed shortly by total failure.



**Fig: Over running clutch with rollers in engaged position (solid drive or coupling)**

### **Planetary Gear System [Epicyclic Gear Train]**

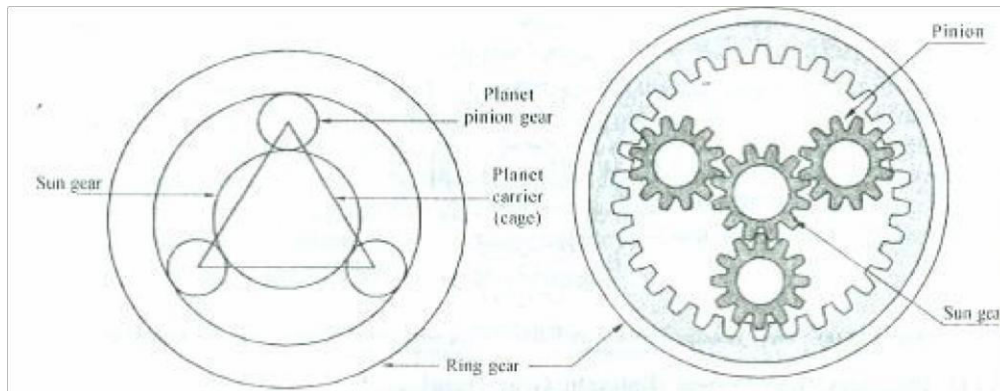
The over drive and automatic transmission makes use of planetary gear system which consists of an (i) Outer ring gear called annulus or internal gear (it's teeth are inside), (ii) Three planet pinions held on pinion shafts and carried by a carrier or cage and (iii) Sun gear. The pinion revolves around the sun gear similar to planets in the solar system. In this system, the planetary gears have bodily motion in addition to rotation about their own axis i.e., their axes rotate about axis of sun gear.

Different speed ratios or torque ratios are obtained by making anyone part stationary (sun gear, planet gears, cage). By inter locking two parts with each other a direct or solid drive is obtained.

Various combinations of the gears are explained as follows:

- 1. Speed Increase:** If we hold the sun gear stationary and turn Planet pinion cage, the pinion shafts will be carried around with the cage. As pinions are meshed with sun gear, they rotate on their shafts and walk around stationary sun gear. The planet pinions are also meshed with the ring gear and hence drives it. This rotates the ring gear faster than the planet pinion cage. By using gears of different sizes, the ratio between planet pinion cage and ring gear may be altered. As an example, if the ring gear makes one complete revolution, the cage turns only 0.7 revolutions. The planet pinions drives the ring gear much faster than the cage and the gear ratio between these two may be 1:0.7. As the driven member (ring gear) turns faster than driving member (planet pinion cage), the system works as a speed increasing mechanism.

2. **Speed Reduction:** Assume that the sun gear is stationary; turning of ring gear will cause the planet pinion cage to turn slowly, than ring gear.  
This is exactly opposite to previous condition and the system functions as speed reduction mechanism. The driving member (ring gear) drives the driven member (cage) slowly.
3. **Speed Increase:** Hold the ping gear stationary and turn the planet pinion cage to drive sun gear. The sun gear is forced to rotate faster than the 'cage, i.e. driven member (sun gear) turns faster than driving member (planet pinion cage) and the system becomes speed increasing mechanism.



(a) Simplified view of planetary gear system      (b) Planetary gear system

4. **Speed Reduction:** If we turn the sun gear to drive planet pinions on their shafts, by keeping ring gear stationary, the pinions walk around the ring gear, as they are in mesh with it. The planet pinion cage is also carried around and hence rotates at lesser speed than the sun gear speed. The sun gear becomes driving member and turns the planet pinion cage (driven member) slowly and a speed reduction is obtained.
5. **Reverse:** Keep the planet pinion cage stationary and turn the ring gear. The planet pinions becomes idlers-and turns the sun gear in the opposite direction to the rotation of ring gear. We get a reverse rotation system and sun gear is turning faster than the ring gear. Ring gear is the driving member and sun gear takes the drive and turns in opposite direction to the ring gear.
6. **Reverse:** Hold the cage stationary and turn the sun gear to drive the ring gear in the reverse direction, but slower than the sun gear.
7. **Direct drive:** The input and output shafts turns at the same speed by locking any two or three members in the planetary gear system. The whole is locked and there is no speed change through the reduction gear system, a direct ratio of 1:1 is obtained. However, if no member is held stationary and no two members are locked together, then the system will not transmit power. The input shaft will turn, without driving out put shaft.

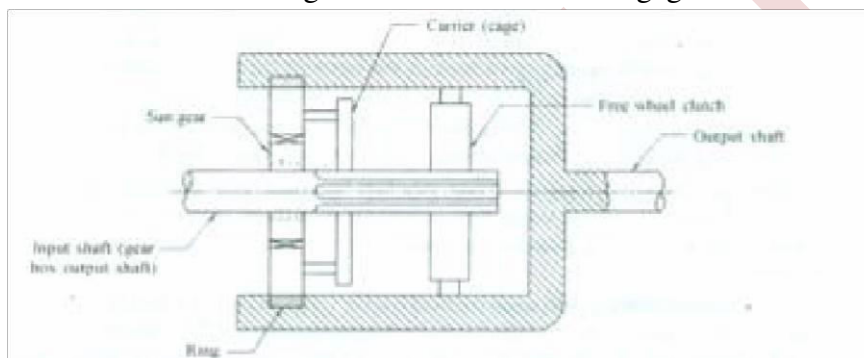
Conditions	1	2	3	4	5	6
Ring gear	$D_n$	$TJ)$	S	S	$T I > Y$	$D \sim$
Cage	$TD \sim$	$DI \setminus$	$TD_i$	$D_n$	S	S
Sun gear	S	S	$D_f)$	$TD,$	$DII)$	T
Speed	Ine.	dee.	Inc.	dee.	Inc. Rev	dec. Rev

The above table shows various possible conditions in a planetary gear system.

**OVER DRIVE OPERATION**

In the over drive, the over running clutch is splined to the transmission output shaft in the back of splined pinion carrier. The ring gear is attached to the over drive output shaft and three planet pinions mounted on a cage which is splined to the transmission main shaft. The sun gear may be allowed to turn or may be locked to keep it stationary. The output shaft over drives the transmission main shaft, when the sun gear is locked.

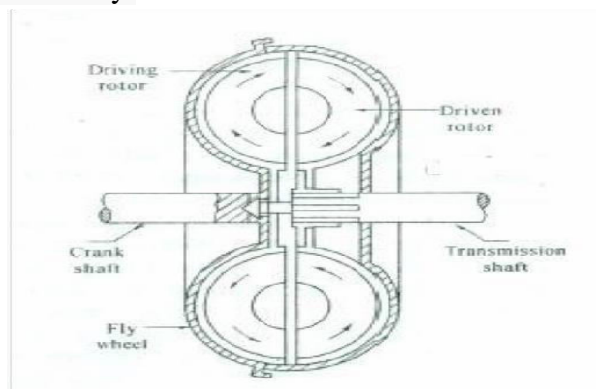
When the transmission main shaft and over drive output shaft are turning at the same speed (or when transmission shaft turning faster than internal gear or over drive alp shaft), the sun gear is free, the over running clutch or free wheel mechanism will drive the internal gear or over drive output shaft. The power directly goes to the clutch cam, which is splined to the transmission main shaft. The clutch cam transmits power through the rollers to the outer race, which is attached to the output shaft. When sun gear is stopped, the planetary action will drive the internal gear faster than cage and clutch hub and the over running clutch will remain disengaged.



**Fig: Overdrive**

**Fluid coupling (fluid flywheel)**

It is a device for transmitting rotation between shafts by means of the acceleration and deceleration of a hydraulic fluid. Structurally, a fluid coupling consists of an impeller on the input or driving shaft and a runner on the output or driven shaft. The two contain the fluid (see illustration). Impeller and runner are bladed rotors, the impeller acting as a pump and the runner reacting as a turbine. Basically, the impeller accelerates the fluid from near its axis, at which the tangential component of absolute velocity is low, to near its periphery, at which the tangential component of absolute velocity is high. This increase in velocity represents an increase in kinetic energy. The fluid mass emerges at high velocity from the impeller, impinges on the runner blades, gives up its energy, and leaves the runner at low velocity.

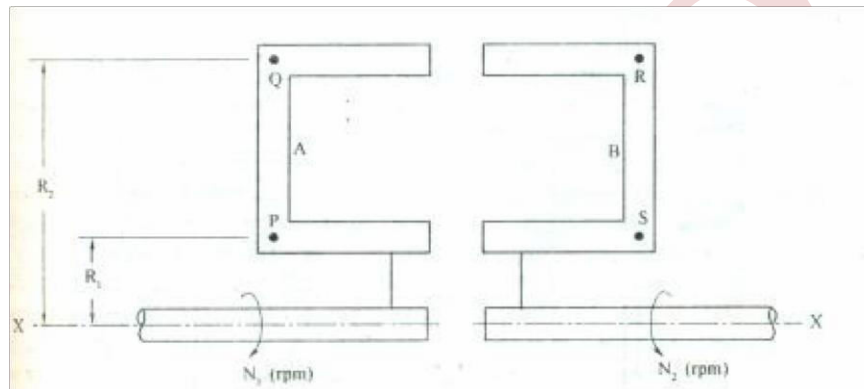


**Fig: Fluid flywheel**

**Construction and working of fluid coupling as follows:**

An automotive fluid coupling consists of a split housing which is rotate by the engine crankshaft. Inside the housing is a driven member is called runner and the driven member is connected by a shaft to the gear box. The driving member is mounted on the crankshaft and it is called impeller.

The driving (input) and driven (output) members are very close with their ends facing each other and enclosed in housing, so that they can be turned without touching each other. The liquid or oil is filled in the housing. The fly wheel housing is divided into a number of cells by means of radial vanes. These cells correspond to similar openings in the driven member.



**Fig: Principal of fluid flywheel**

When the crankshaft turns, the driving member or impeller also rotates. The fluid flows outwards due to the centrifugal force and circulates from the flywheel to the driven member. Now, the fluid tends to rotate the driven member because the fluid is also carried out round by the driving member. The fluid is also carried out round by the driven member so; the fluid tends to rotate the driven member. Thus the torque is transmitted from the crankshaft to the gear box shaft. The liquid coupling is not suited for use with an ordinary gear box. It is generally used in conjunction with epicyclical gears to provide a semi or fully automatic gear box.

**Torque converter**

A torque converter is generally a type of fluid coupling (but also being able to multiply torque) that is used to transfer rotating power from a prime mover, such as an internal combustion engine or electric motor, to a rotating driven load. The torque converter normally takes the place of a mechanical clutch in a vehicle with an automatic transmission, allowing the load to be separated from the power source. It is usually located between the engine's flex plate and the transmission.

The key characteristic of a torque converter is its ability to multiply torque when there is a substantial difference between input and output rotational speed, thus providing the equivalent of a reduction gear. Some of these devices are also equipped with a temporary locking mechanism which rigidly binds the engine to the transmission when their speeds are nearly equal, to avoid slippage and a resulting loss of efficiency.

Torque converters are sealed units; their innards rarely see the light of day, and when they do, they're still pretty hard to figure out

Imagine you have two fans facing each other. Turn one fan on, and it will blow air over the blades of the second fan, causing it to spin. But if you hold the second fan still, the first fan will keep right on spinning.

That's exactly how a torque converter works. One "fan," called the impeller, is connected to the engine (together with the front cover, it forms the outer shell of the converter). The other fan, the turbine, is connected to the transmission input shaft. Unless the transmission is in neutral or park, any motion of the turbine will move the vehicle.

Instead of using air, the torque converter uses a liquid medium, which cannot be compressed oil, otherwise known as transmission fluid. Automatic transmission cars use a torque converter. This article will discuss why automatic transmission cars need a torque converter and how a torque converter works.

The torque converter in an automatic transmission serves the same purpose as the clutch in a manual transmission.

The engine needs to be connected to the rear wheels so the vehicle will move, and disconnected so the engine can continue to run when the vehicle is stopped. One way to do this is to use a device that physically connects and disconnects the engine and the transmission – a clutch. Another method is to use some type of fluid coupling, such as a torque converter, which is located between the engine and the transmission.

There are three components inside the very strong housing of the torque converter which work together to transmit power to the transmission:

- Pump
- Turbine
- Stator

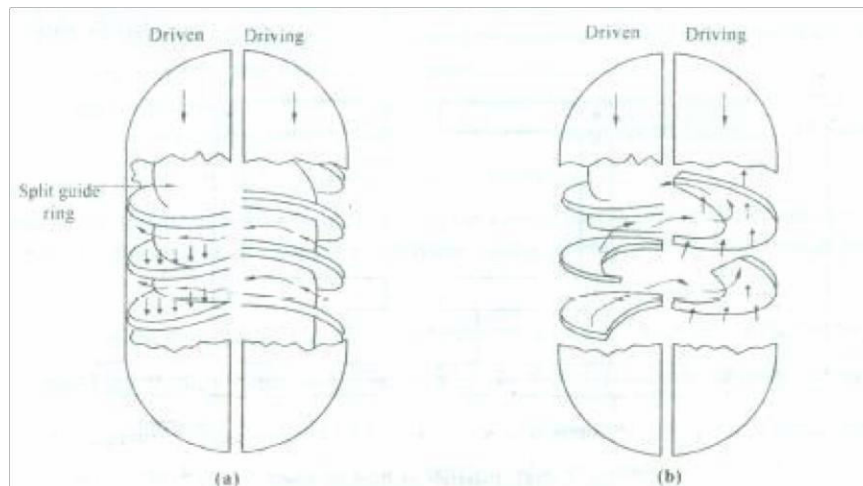
The **pump** inside a torque converter is a type of centrifugal pump. As it spins, fluid is flung to the outside, much as the spin cycle of a washing machine flings water and clothes to the outside of the wash tub. As fluid is flung to the outside, a vacuum is created that draws more fluid in at the center.

The fluid then enters the blades of the **turbine**, which is connected to the transmission (the spline in the middle is where it connects to the transmission.) The turbine causes the transmission to spin, which basically moves your car. The blades of the turbine are curved so that the fluid, which enters the turbine from the outside, has to change direction before it exits the center of the turbine. It is this directional change that causes the turbine to spin.

As the turbine causes the fluid to change direction, the fluid causes the turbine to spin.

The fluid exits the turbine at the center, moving in a different direction than when it entered. The fluid exits the turbine moving opposite the direction that the pump (and engine) are turning. If the fluid were allowed to hit the pump, it would slow the engine down, wasting power. This is why a torque converter has a stator

The **stator** resides in the very center of the torque converter. Its job is to redirect the fluid returning from the turbine before it hits the pump again. This dramatically increases the efficiency of the torque converter.



**Fig: Cut Section of torque converter**

In brief, the torque converter is a type of fluid coupling, which allows the engine to spin somewhat independently of the transmission. It is responsible for pressurizing automatic transmission fluid, a pressurization that supplies the force necessary to shift transmission gears.

A worn or dysfunctional torque converter can prevent transmission fluid from being properly pressurized, which in turn negatively impacts transmission gear function and operation. A systematic checkup by a professional is the best way to isolate the cause of the operating problems and recommend the most effective solution.

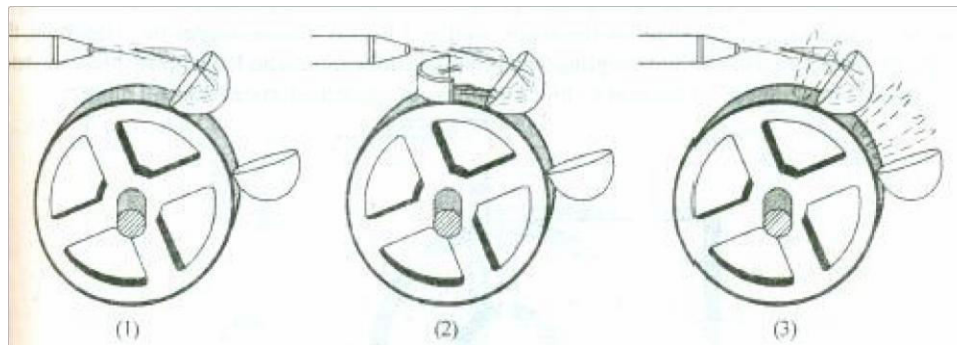
If properly tuned, this complex device can have a tremendous impact on your vehicle's performance, economy and durability, and turn your automatic into a powerhouse!

### Operation

A torque converter has three stages of operation

- **Stall:** The prime mover is applying power to the impeller but the turbine cannot rotate. For example, in an automobile, this stage of operation would occur when the driver has placed the transmission in gear but is preventing the vehicle from moving by continuing to apply the brakes. At stall, the torque converter can produce maximum torque multiplication if sufficient input power is applied (the resulting multiplication is called the *stall ratio*). The stall phase actually lasts for a brief period when the load (e.g., vehicle) initially starts to move, as there will be a very large difference between pump and turbine speed.
- **Acceleration:** The load is accelerating but there still is a relatively large difference between impeller and turbine speed. Under this condition, the converter will produce torque multiplication that is less than what could be achieved under stall conditions. The amount of multiplication will depend upon the actual difference between pump and turbine speed, as well as various other design factors.
- **Coupling:** The turbine has reached approximately 90 percent of the speed of the impeller. Torque multiplication has essentially ceased and the torque converter is behaving in a manner similar to a simple fluid coupling. In modern automotive applications, it is usually at this stage of operation where the lock-up clutch is applied, a procedure that tends to improve fuel efficiency.

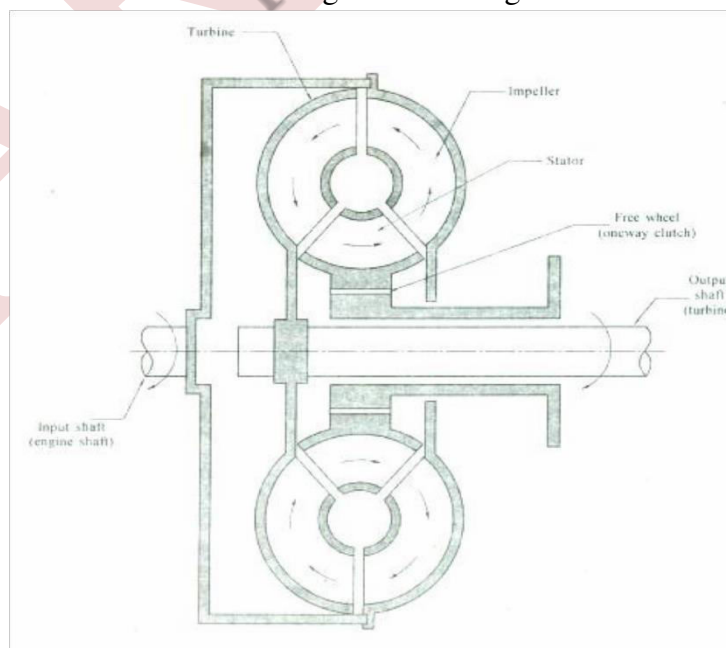




**Fig: Torque Multiplication by using stator**

The key to the torque converters ability to multiply torque lies in the stator. In the classic fluid coupling design, periods of high slippage cause the fluid flow returning from the turbine to the impeller to oppose the direction of impeller rotation, leading to a significant loss of efficiency and the generation of considerable waste heat. Under the same condition in a torque converter, the returning fluid will be redirected by the stator so that it aids the rotation of the impeller, instead of impeding it. The result is that much of the energy in the returning fluid is recovered and added to the energy being applied to the impeller by the prime mover. This action causes a substantial increase in the mass of fluid being directed to the turbine, producing an increase in output torque. Since the returning fluid is initially traveling in a direction opposite to impeller rotation, the stator will likewise attempt to counter-rotate as it forces the fluid to change direction, an effect that is prevented by the one-way stator clutch.

Unlike the radially straight blades used in a plain fluid coupling, a torque converters turbine and stator use angled and curved blades. The blade shape of the stator is what alters the path of the fluid, forcing it to coincide with the impeller rotation. The matching curve of the turbine blades helps to correctly direct the returning fluid to the stator so the latter can do its job. The shape of the blades is important as minor variations can result in significant changes to the converter's performance.



**Fig: Torque converter**

During the stall and acceleration phases, in which torque multiplication occurs, the stator remains stationary due to the action of its one-way clutch. However, as the torque converter approaches the coupling phase, the energy and volume of the fluid returning from the turbine will gradually decrease, causing pressure on the stator to likewise decrease. Once in the coupling phase, the returning fluid will reverse direction and now rotate in the direction of the impeller and turbine, an effect which will attempt to forward-rotate the stator. At this point, the stator clutch will release and the impeller, turbine and stator will all (more or less) turn as a unit.

Unavoidably, some of the fluid's kinetic energy will be lost due to friction and turbulence, causing the converter to generate waste heat (dissipated in many applications by water cooling). This effect, often referred to as pumping loss, will be most pronounced at or near stall conditions. In modern designs, the blade geometry minimizes oil velocity at low impeller speeds, which allows the turbine to be stalled for long periods with little danger of overheating.

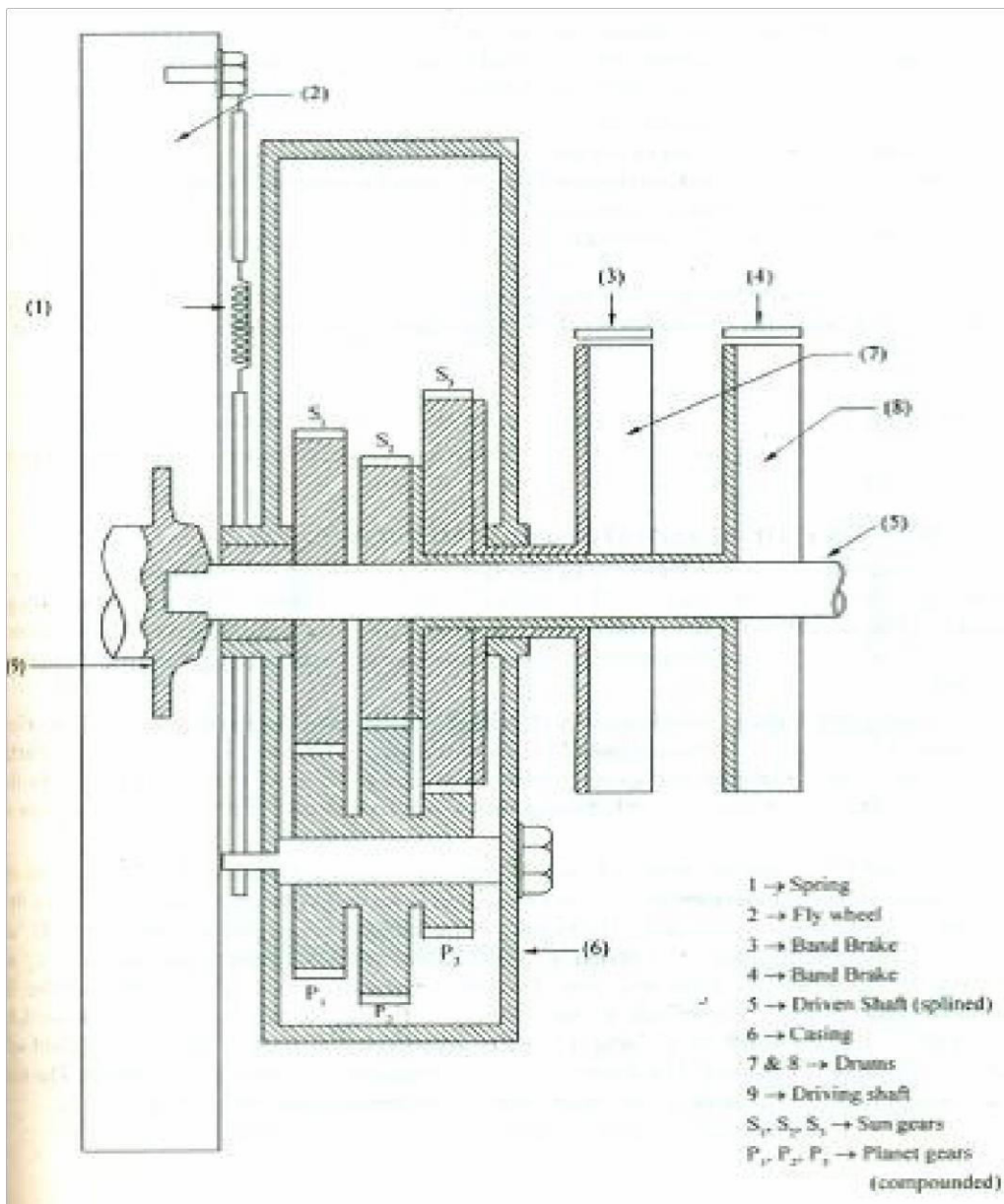
### EPICYCLIC GEAR BOX

An Epicyclic gear box consists of two, three or even four epicyclic or planetary gear sets each giving a definite gear ratio, when the brakes are applied, one of the member may become stationary and the train to which that member belongs comes into operation. If that member is released and another one brought to rest by using its brake, another train will be brought in to operation. The top gear or direct gear is obtained by clutching the driving member direct to the driven member by means of an ordinary cone clutch or plate clutch. The direct drive is also obtained by locking two members together. In this case all wheels and arms will revolve as one solid mass and planet gears will be at rest on their pins, but they will be rotating bodily with the arms.

This consists of a casing (6) which forms common arm for all the trains and carries the compound planet gears P1, P2 and P3 on pins as shown. A number of springs (I) are used between casing and fly wheel, to smooth out torque fluctuations of the engine. The planet 'P.' meshes with sun wheel '(S)', which is splined to the driven shaft (5). The planets P2 and P3 are in mesh with sun wheels S2 and S, which are mounted on the sleeves integral with brake drums '8' and '7' respectively. The sun gear S2 will be held stationary by applying brake '4' on brake drum '8' and (S2 - P2 - P, - S) will constitute a train, the fixed sun being smaller than the driven sun. This gives a forward gear and turns the driven shaft '5' in the same direction as the engine shaft, but at a slower speed.

If brake '3' is applied to the brake drum '7', then sun gear 'S' will become stationary and this constitutes a gear train S3 - P3 - P, - S) and a reverse gear is obtained. '

By locking both brake drums '7' & '8' together, a direct drive is obtained and the whole gear rotates as "Solid".



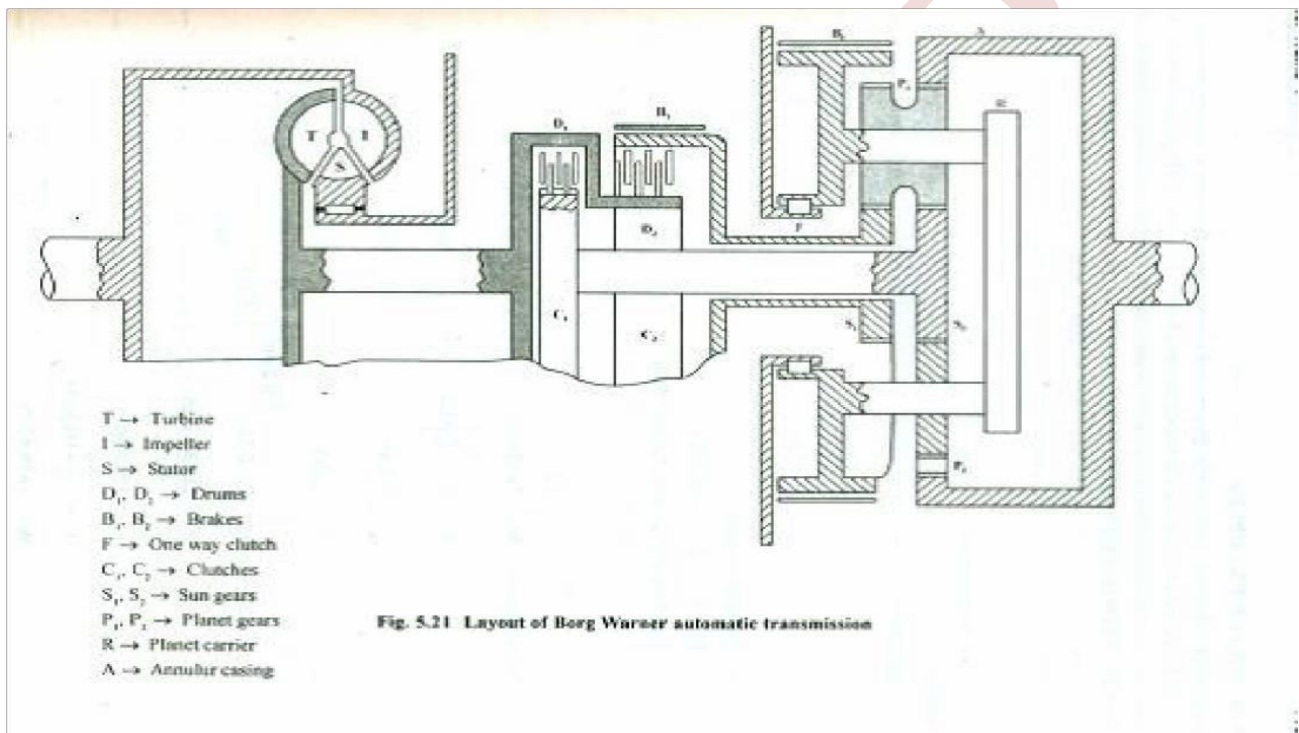
**Fig: Epicyclic gearbox**

**PRINCIPLE OF AUTOMATIC TRANSMISSION**

The automatic transmission systems are efficient, convenient, easy to operate, but they are relatively expensive to manufacture. The automatic transmission shifts in accordance with engine speed and load conditions. The essential components are converter housing, case oil pan, extension housing. Essentially it is a combination of torque converter and epicyclic gear train and multi plate clutches.

The automatic transmission is broadly classified into (1) Semi-automatic - clutch operation is automatic, gear selection is manual and (2) Fully automatic - clutch operation and, gear selection both are automatic and gear changing is done by pressing the accelerator pedal only. In fully automatic transmission there are only two controls, accelerator and brake. In addition there is a selector lever.

The figure shows layout of Borg Warner automatic transmission. This consists of a single stage (three members) torque converter coupled to an epicyclic gear box which gives three forward and one reverse speed ratio. The turbine of the impeller is integral with the drums 'D)' and 'D/' of the clutches 'C)' and 'C/'. When 'C)' is engaged, the drive goes to the sun gear 'S/' and if brake 'B)' is applied, it gives low gear. The second gear is obtained by applying brake 'B/' instead of 'B)'. The one way clutch 'F' prevents planet carries 'R' from rotating back ward, but allows it to rotate forwards. If 'C)' and 'C/' are engaged simultaneously, the gear is locked solid and a direct drive is obtained. For reverse gear, C2 is engaged and brake B2 is applied. The drive then goes from S) to P, and hence to the annulus A, the planet carrier being fixed.



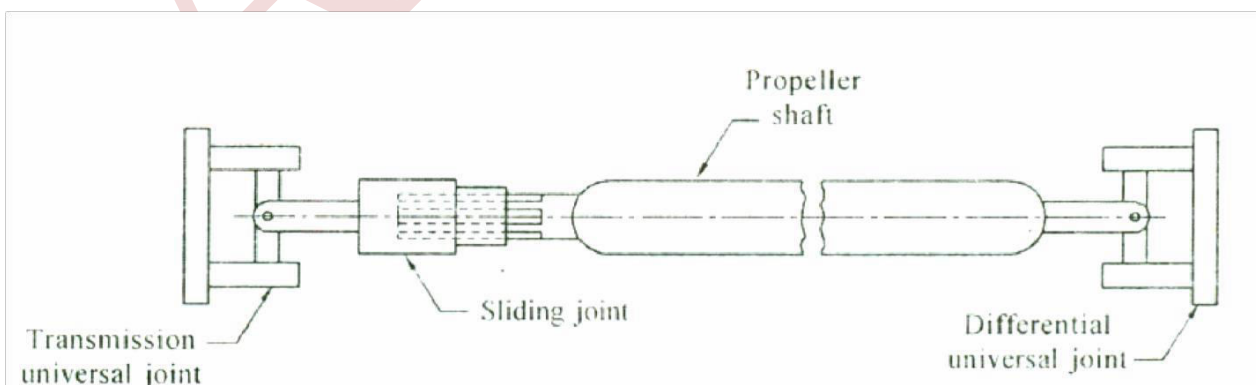
**UNIT - 6****DRIVE TO WHEELS****INTRODUCTION**

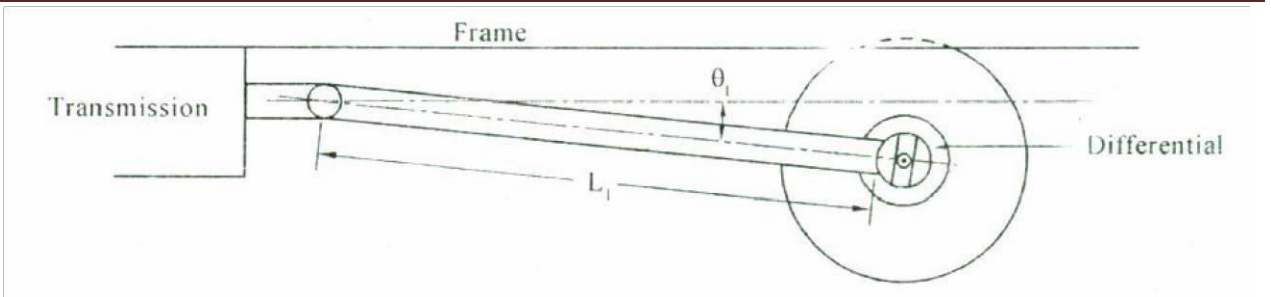
This chapter describes the purpose, construction and operation of drive lines which includes driving connection between the transmission and driving wheels. In an automobile, the drive line consists of a propeller shaft, one or two universal joints depending on the type of drive and a slip joint. All these are used to transmit engine power from transmission to the differential which is provided at the rear wheel axle. In some automobiles [front engine - front wheel drive], the transmission is directly coupled to the front wheel axle by axle drive shafts, and no propeller shaft is used. Even in rear engine rear wheel drive automobiles, the transmission may be directly coupled to the rear wheel axle.

**PROPELLER SHAFT**

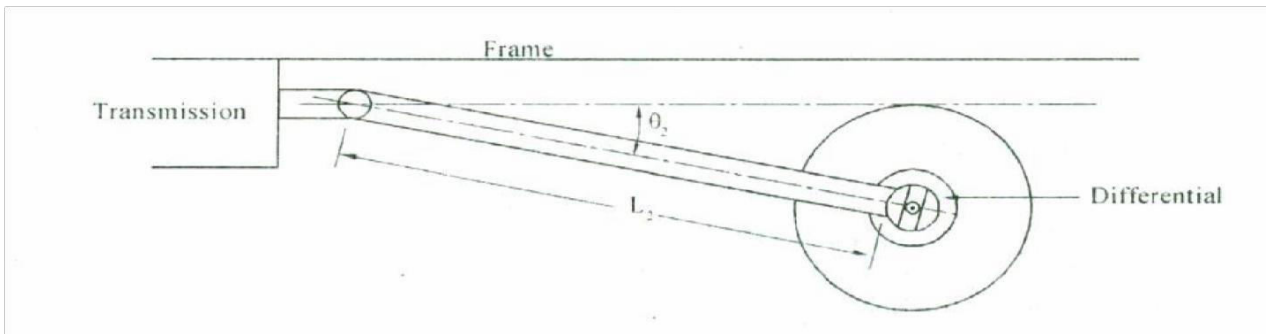
It is also called drive shaft. The front engine rear wheel drive automobiles require a propeller shaft to connect transmission output shaft to the differential at the rear axle. The propeller shaft transmits rotary motion of the transmission output shaft to the differential, causing the rear wheels to rotate. At high speeds, whirling of propeller shaft causes bending stresses in the material which is to be reduced. Also it has to withstand torsional loads. To reduce this, propeller shaft should be made tubular and should be perfectly balanced. One or two universal joints are used to permit variations in the angle of drive. The engine and transmission are rigidly attached to the frame of the vehicle while rear axle housing with wheels and differential is attached to the frame by springs. The springs compress or expand due to road irregularities which changes angle of drive between the propeller and transmission shafts. This also changes distance between the transmission and the differential. The universal joint accounts for variations in the angle of drive. The slip joint or sliding joint serves to adjust the effective length of the propeller shaft when demanded by the rear axle movements.

The figure shows a propeller shaft with two universal joints and a sliding joint. Sliding joint is formed by the internal splines on the sleeve attached to the left universal joint and external splines on the propeller shaft.

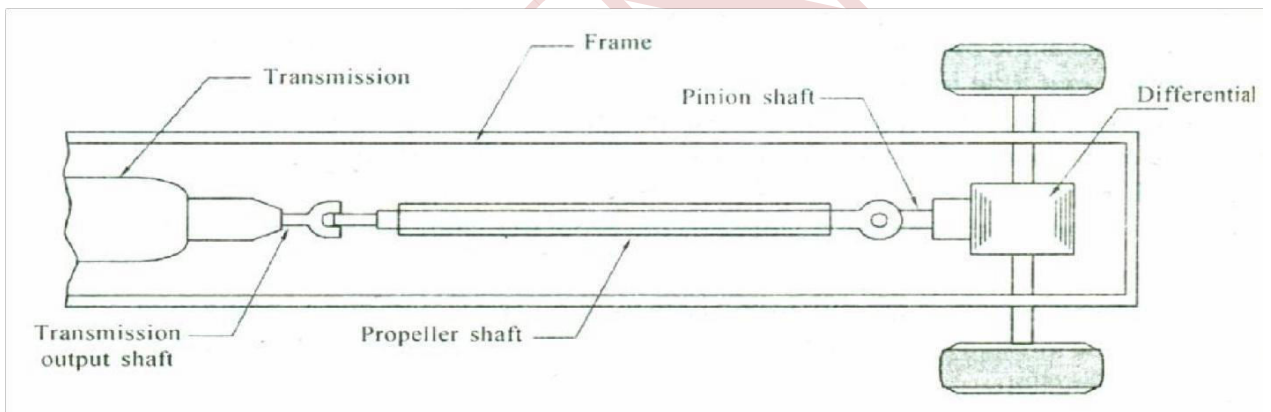
**Fig: Propeller shaft**



**Fig: Propeller shaft length ( $L_1$ ) increased**



**Fig: Propeller shaft length ( $L_2$ ) decreased**



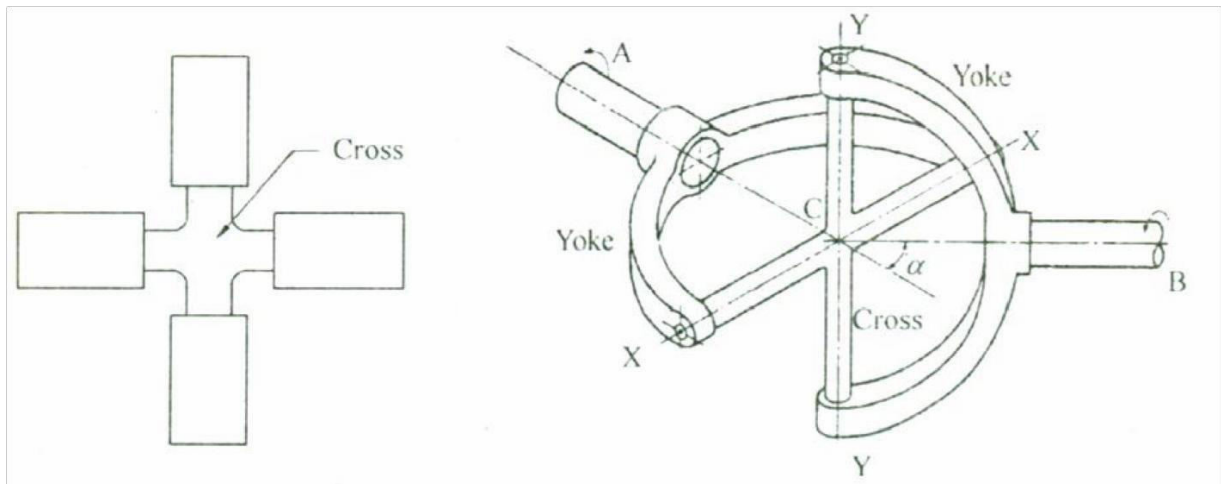
**UNIVERSAL JOINTS**

It is known that a solid drive line would be bent and finally broken as the angle of drive changes. So a flexible joint called universal joint is used to move the drive line or propeller shaft without breaking. The universal joint transmits the torque even though the rear axle is moving up and down.

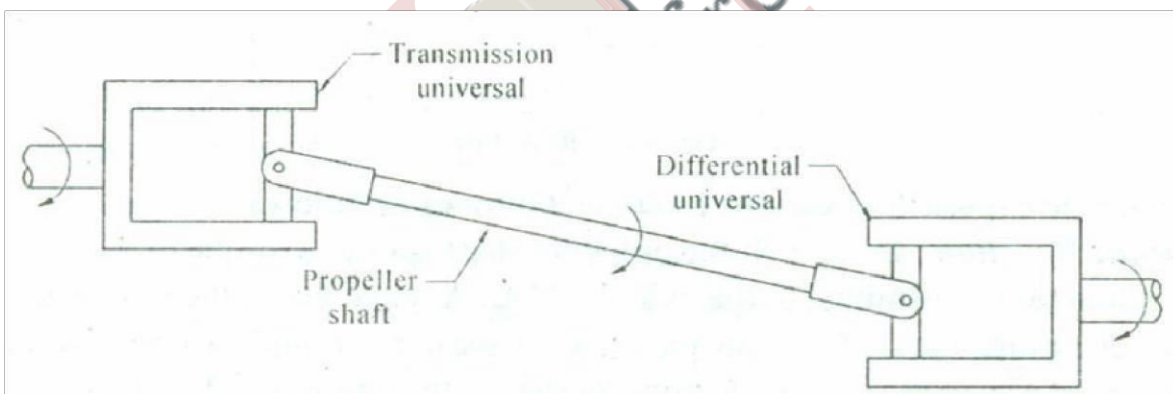
Universal joints are used as flexible connection between two rigid shafts at an angle with each other. These joints allow angular movement between two shafts and transmit power at an angle. In automobiles universal joints are used not only to permit power transmission from horizontal transmission output shaft to the propeller shaft which is at an angle to the horizontal (as rear axle is usually lower than transmission shaft), but also allow the change of this angle due to movement of rear axle up and down on surface irregularities. Without this device power transmission under these conditions would be impossible.

The simplest type of universal joint is Hooke's joint. It is simple and compact in construction and is efficient for small angular movements of the propeller shaft say up to  $20^\circ$ . It consists of two -

'Y' shaped yokes, one on driving (A) and another on the driven (B) shafts, whose axes are inclined to each other. The spider or cross consists of four arms, two of which are supported in the bushes in the yoke of shaft 'A', while the other two are supported in the yoke of shaft 'B'. Thus shaft 'A' can have angular rotation about x-x and shaft 'B' about y-y. The driving shaft 'A', drives the spider (cross), causes the rotation of shaft 'B' through the arms of cross 'C'.



**Fig: Hooke's joint. Shaft 'A' is transmitting torque in horizontal plane; shaft 'B' is transmitting the same at different angle.**



**Fig: Universal joints in action. As rear axle moves up and down, universals allow drive angles to change without bending propeller shaft.**

In the universal joint explained above, the driven shaft speed does not remain constant or uniform. Depending on the shaft inclinations, the driven shaft speed fluctuates. It is zero for zero angle, the magnitude increases when the angle is large. To achieve uniform driven shaft speed, two universal joints have to be used at two ends of propeller shaft.

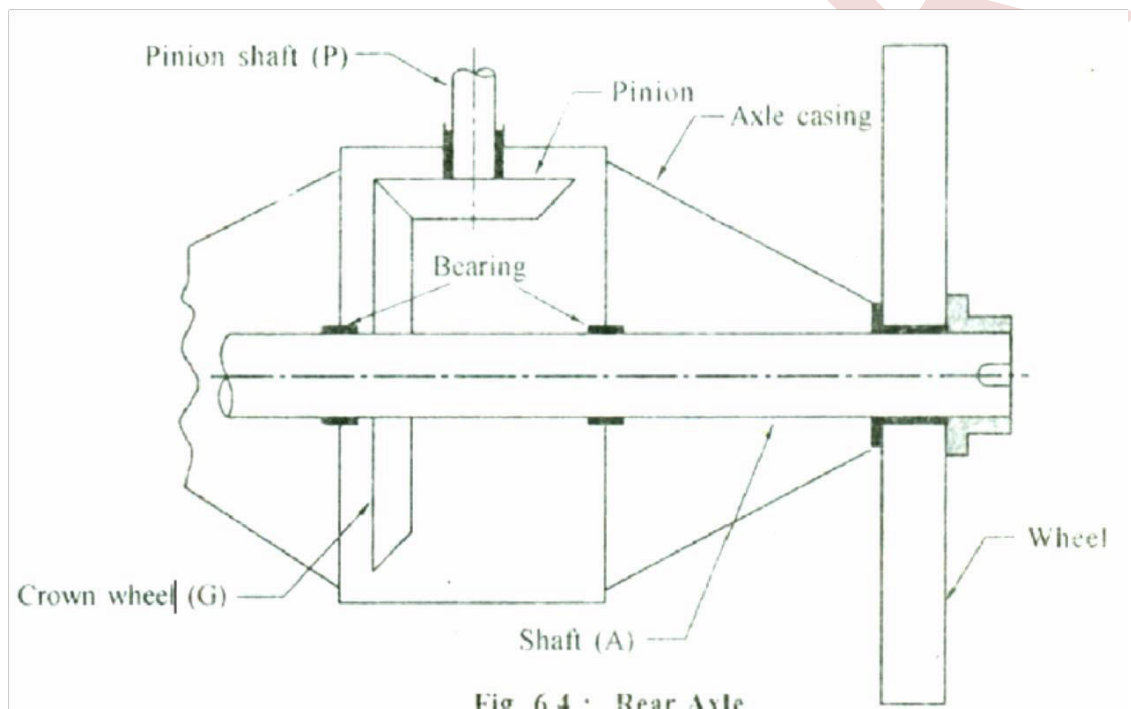
**REAR AXLE (BACK AXLE)**

The propeller shaft takes the drive from transmission and transmits it to the differential, from where the power goes to the driving wheels through rear axles. A dead axle is one which carries a part of the vehicle weight, but does not drive the wheels connected to it. The live axle carries vehicle weight and also drives the wheels connected to it.

The functions of live rear or back axle are

1. It acts as a beam, up on the ends of which the road wheels can revolve and through which the weight of body and load can be transmitted, via the springs and road wheels, to the ground.
2. It acts as a housing to support the final drive, the differential and the shafts that transmit the drive to the road wheels.

The figure shows simplified view of a live rear axle for a front engine, rear driven automobile. The pinion shaft is supported in the bearings in axle casing and takes the drive from propeller shaft. The pinion shaft drives a crown wheel which is in mesh with it and mounted on shaft. The end caps are used to restrict the wheels in the axial direction. The wheels are mounted on the ends of the axle shaft. In actual case, two half shafts are used instead of one shown here.



**Fig: Rear Axle**

The back axle experiences various forces and torques as follows

- i. **Torque Reaction:** In fig, the propeller shaft applies a torque to the pinion shaft 'P', which in turn transmitted to the axle shaft 'N'. Assume that if the road wheels are fixed, then on turning the shaft 'P', the pinion will have to roll round the crown wheel 'C'. Thus, if the road wheels are fixed with propeller shaft in the turning condition, the pinion will tend to climb around the crown wheel. As axle casing supports pinion, it will be subjected to a force which causes it to rotate. The torque producing this action is the equal and opposite reaction to the driving torque which is applied to the road wheels. This phenomenon is called torque reaction, due to which axle casing tends to turn opposite to the direction of road wheels rotation. This has to be opposed otherwise propeller shaft would be subjected to heavy bending. This can be avoided by attaching an arm or a member to the casing and the other end of which is secured to the frame. The braking torque on the axle casing is opposite in direction to the torque reaction.



- ii. **Driving Thrust:** Driving torque produced in the engine causes the thrust to be produced in the road wheels, which has to be transmitted from axle casing to the chassis frame and the body of the vehicle. To do this, thrust members or radius rods are used. These members are attached to the axle casing and chassis frame in the longitudinal direction.
- iii. **Weight of the Body:** If we consider rear axle as a beam which is supported at the ends and loaded at two points as shown in figure. The rear axle supports, body weight  $OW'$  through two suspension springs and  $R_1$  and  $R_2$  are the reaction forces from the road wheels. This weight causes shear force and bending moment in the axle shaft.
- iv. **The sideways forces [Side thrust] :** The rear axle also experiences side thrust or pull due to any side load on the wheel. (Ex: Cornering force). Pan hard rod may be used to hold the axle in position against the side thrust.

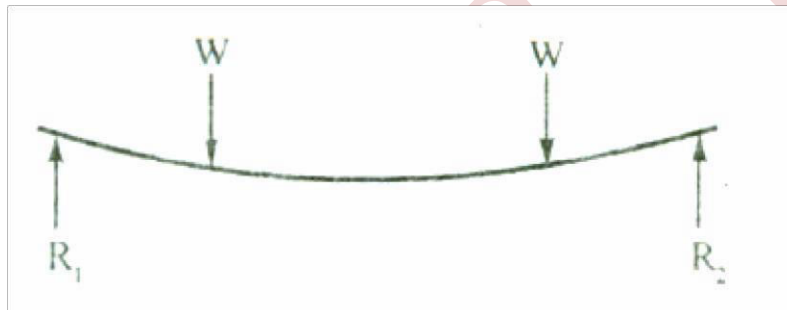


Fig: Rear axle as a beam

### REAR AXLE DRIVES

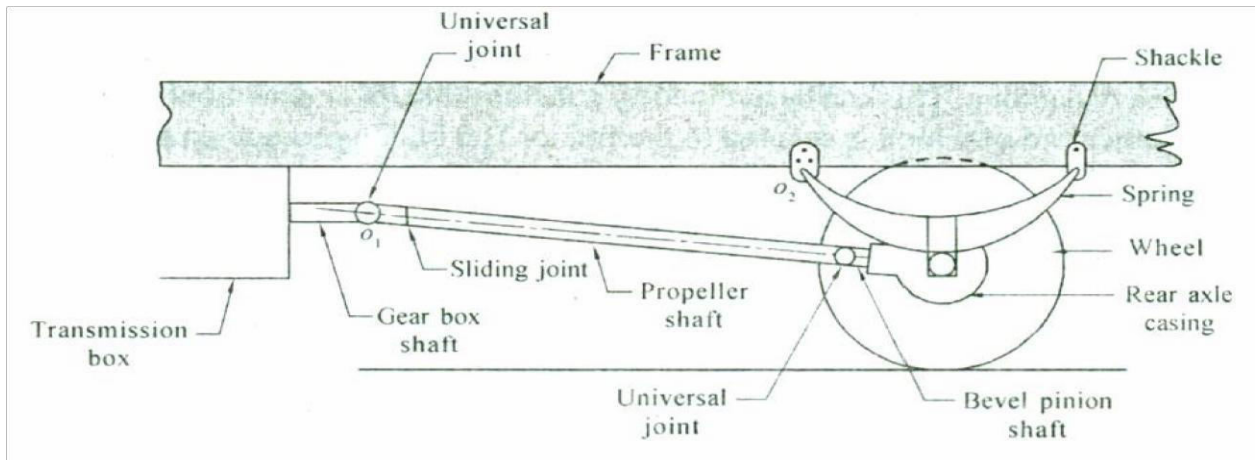
From the above discussion, it is clear that the connections between the axle and the frame must be capable to withstand.

- Weight of body
- Torque reaction
- The driving thrust
- The sideways forces.

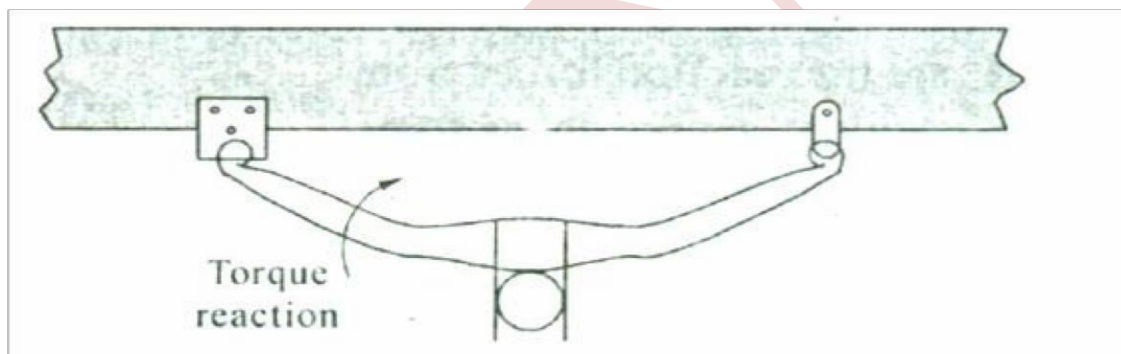
Different arrangements are used and are classified as

- i. The springs act as torque members, thrust members and transmit the side way forces.
- ii. The springs act as thrust members and transmit side way forces, but a separate torque member is used.
- iii. The springs transmit sideways forces, but torque reaction, and driving thrust are taken by separate members.
- iv. The springs take only weight of the body, and torque reaction, driving thrust and sideways forces are taken by separate members.

In all these arrangements, springs takes weight of the body. Many drives are used, out of which the two important rear axle drives are (i) Hotchkiss drive & (ii) Torque tube drive.



**Fig: (a) Hotchkiss drive**



**Fig: (b) Bending of spring under torque reaction**

The Hotchkiss drive is most simple and widely used system. In this arrangement, the springs besides taking weight of the body, also take the torque reaction, driving thrust and side forces. It consists of an open propeller shaft secured to the transmission output shaft and differential pinion gear shaft (Bevel pinion shaft). The propeller shaft is provided with two universal joints and a sliding joint as shown in figure. The springs are bolted to the axle casing. The front end of the spring is rigidly fixed to the frame, while the rear end is connected to the frame by swinging links or shackles. The front half of the spring will transmit the driving thrust to the frame.

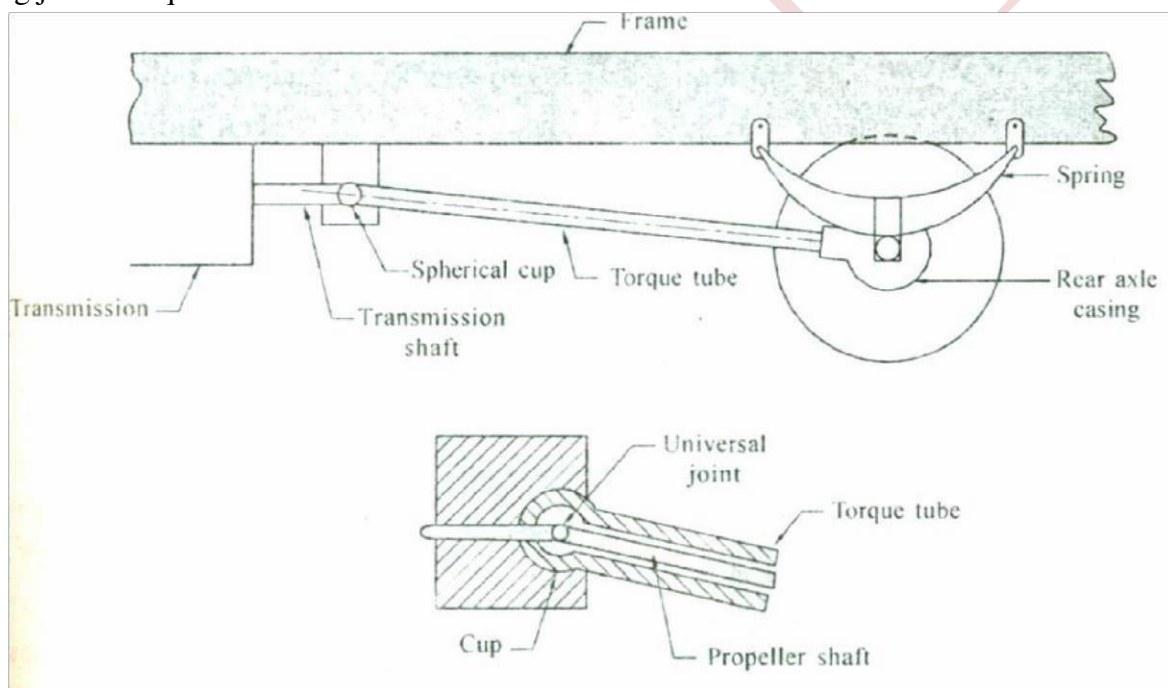
It is seen that, the axle casing cannot turn under the torque reaction without causing the springs to flex which is shown in figure (b). The springs offer considerable resistance to this deformation, thus torque reaction is overcome. The spring deflects as it experiences torque reaction and the bevel pinion shaft changes its position. Under this condition the axis of bevel pinion shaft will not pass through the centre of the front universal joint. Therefore, if there is no universal joint at the rear end, the propeller shaft will bend. To overcome this effect, two universal joints, one at the front and other at the rear end are used.

Again the rear axle moves up and down in a circle with the front spring support at the frame

(O) as centre. But the propeller shaft moves in a circle about 'O,' as centre i.e., the centre of front universal joint. Since the two centers do not coincide, the distance between the front universal joint and pinion shaft of the axle [length of propeller shaft] will alter during the up and down movement of the axle and to accommodate this, a sliding joint is to be used in the propeller shaft.

### Torque Tube Drive

In this type, the springs take body weight and side thrust only. The torque reaction and driving thrust are taken by another member called Torque tube. These torque tubes are made tubular and usually surround the propeller shaft. One end of torque tube is attached to the axle casing while the other end which is spherical in shape fits in the cup fixed to the frame as in figure. As torque tube takes torque reaction, the axis of bevel pinion shaft will not change and always pass through the centre of spherical cup, if the universal joint connecting propeller shaft and transmission shaft is located exactly at the centre of spherical cup. Hence only one universal joint is used at the front end and no universal joint is needed at the rear end of the propeller shaft. So also pinion shaft propeller shaft will move about the same centre i.e. about the centre of spherical cup. Hence no sliding joint is required in this case.



**Fig: Torque tube drive**

In both drives leaf springs take the side thrust. When coil springs are used, they are not able to take side loads on therefore a separate member is used which is called "Panhard rod". The panhard rod is in the form of transverse radius rod fixed parallel to wheel axis with one end attached to axle casing and the other end to the chassis frame.

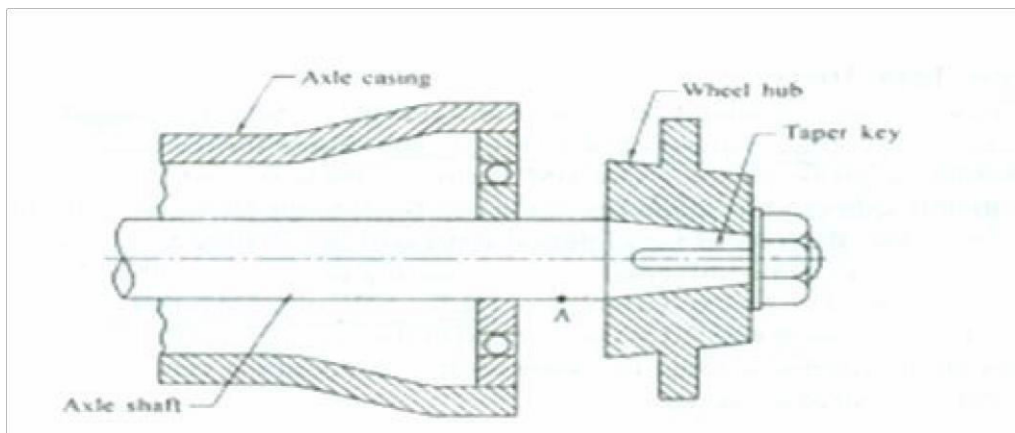
### REAR AXLE SHAFT SUPPORTING

The rear live axle half shaft experiences following loads,

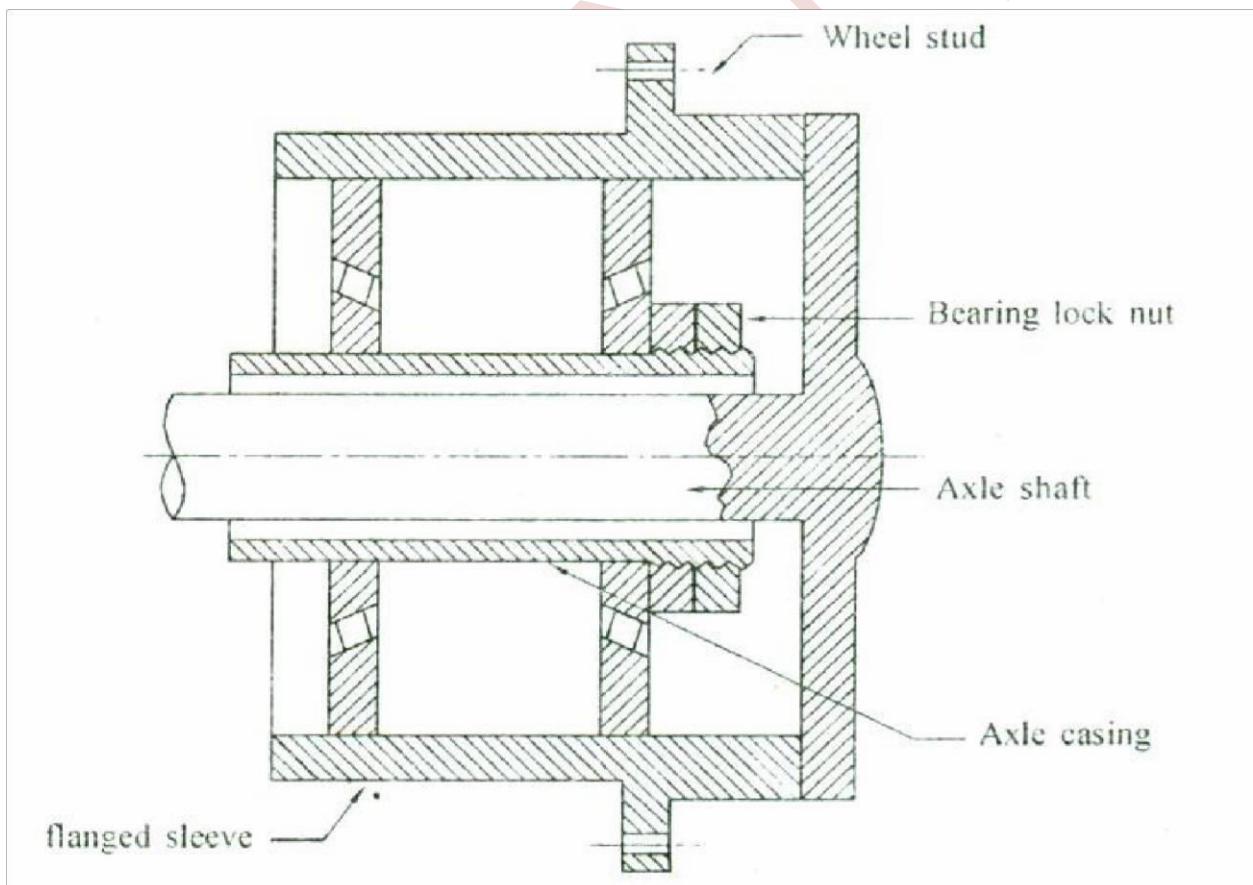
1. Vehicle weight causes shearing force
2. Driving torque.

3. Bending moment due to end thrust and its reaction from the tyres on ground.
4. End thrust resulting from cornering side wind etc.

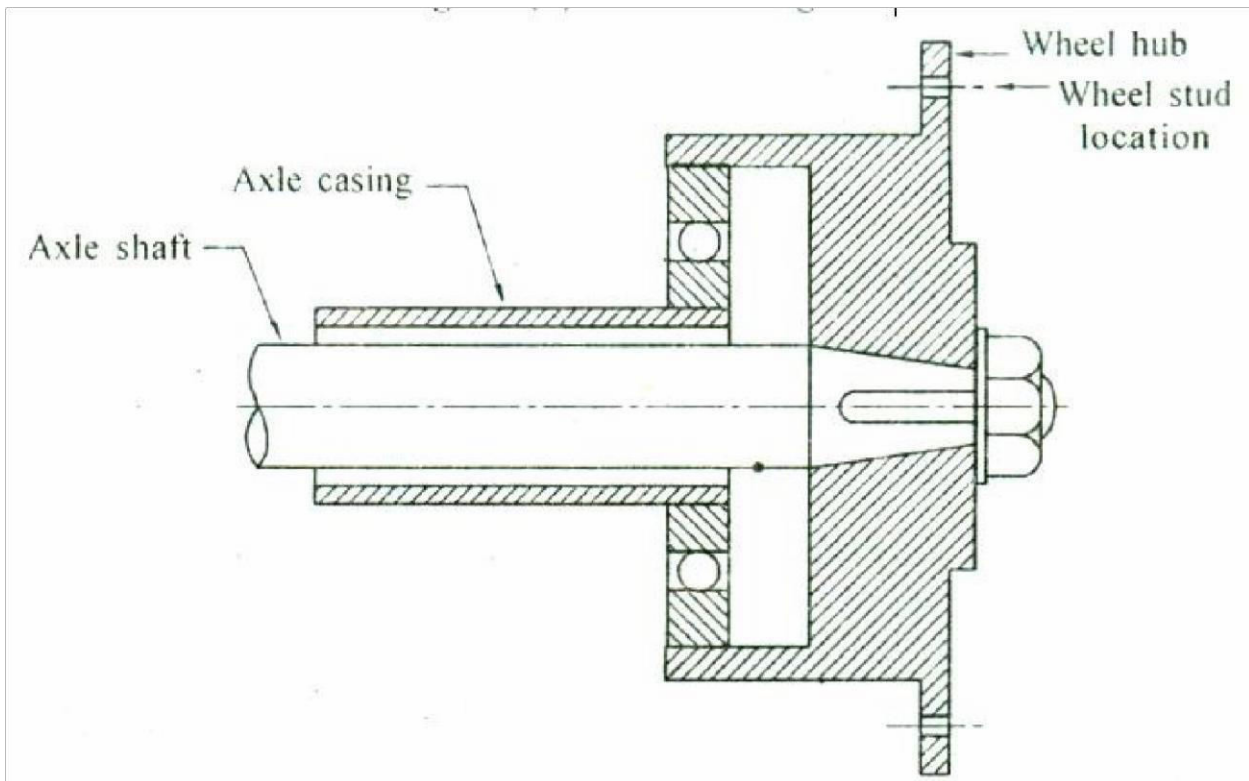
There are three types of live axle - Semi floating, three quarter floating and full floating.



**Fig: (a) Semi floating axle**



**Fig: (b) Full floating axle**



**Fig: (c) Three quarter floating axle**

### **Semi -Floating Axle**

This is used on most passenger vehicles and light commercial vehicles. The inner end of the axle shaft is supported only by the differential side gear, the differential case (carrier) carries the inner bearing between it and the axle housing that supports it. The inner end of the axle shaft thus is relieved of the job of supporting the vehicle weight by the axle casing. The outer end supports vehicle weight and takes end thin. Hence, this construction is called "Semi - Floating".

Here wheel hub is directly connected to the axle shaft. The splined inner end is supported by the final drive unit; the axle casing supports the wheel bearing which is placed inside its outer end. In this case the axle shaft supports all the loads. Each of the half shafts receives the vehicle load through casing and bearing. This causes a bending load and a tendency to shear at the point 'A'. Therefore, the axle shafts takes the bending moments caused by skidding, turning and wobbling of the wheels. As axle shafts have to support all loads, larger diameters have to be used for the same torque transmission compared to outer types of axle supporting.

### **Full Floating Axle**

This type is very robust and is used on heavy trucks. The wheel hub is supported by two bearings running directly upon the axle casing. The axle shaft is fastened to the wheel hub flange by using some kind of coupling which transmits rotary motion of the axle shaft to the hub and wheel. The two taper roller bearings supports axle casing in the hub and takes side load. Thus the axle shafts have to carry only driving torque. The vehicle weight is completely supported by the wheels and the axle casing. As axle shafts carry only driving torque, they can be removed and replaced without

removing the wheel or disturbing the differential. In this case, the wheels remain in position even if the axle breaks which is not possible with other arrangements. It is more expensive, bulkier and heavier than any of the other types.

### Three - Quarter Floating Axle

This type is used on medium commercial vehicles and some passenger cars. This is a compromise between more robust full floating type and simplest semi-floating type. In this type, bearing is located between the axle casing and the hub instead of between the axle casing and the shaft as in case of semi-floating type. Here the axle shaft has to take end loads and driving torque and is not subjected to any bending or shearing actions due to vehicle weight. The axle casing supports these two through the hub and bearing.

### DIFFERENTIAL

When an Automobile negotiates a turn, the distance travelled by outside wheels is greater than that travelled by inside wheels in the same time. If the wheels are mounted on dead axles, so that they turn independent to each other (like front wheels of an ordinary passenger vehicle), the wheels will turn at different speeds to compensate for the difference in travel. But if the engine drives the wheels, some device is necessary which will allow the wheels to revolve at different speeds. To do this a device called differential is provided in the rear axle. This will increase the speed of outside wheels and reduce the speed of inside wheels, when the vehicle travels around a corner, in the mean time keep the speed of all the wheels same when the vehicle is going straight ahead. This avoids skidding when the vehicle is taking turn.

### Operation of differential

It consists of a drive pinion or bevel pinion, attached to the shaft which is coupled to the propeller shaft. A crown wheel or ring gear which is bolted to the differential cage is in mesh with the bevel pinion. The cage carries a cross pin or spider (cross pin is used when two pinion gears are employed and spider is used when four pinion gears are used) to support two differential pinion gears which are in mesh with the two differential side gears (sun gears) which are splined to the axle half shafts. The ring gear (crown - wheel) is free to rotate on the half shaft as shown.

When the propeller shaft turns the bevel pinion, the pinion will turn the crown wheel. The crown wheel in turn will revolve the differential cage and cross pin. The axle side gears will still not turn. By adding two differential pinion gears (The cross pin will pass through these gears) that mesh with the side gears, the revolving cage will turn the axle side gears with it.

When the vehicle is going straight ahead, the crown wheel turns the cage. The differential pinion gears and axle side gears are moving around with the cage and pinion gears do not rotate on the cross pin or about its own axis (no relative movement between teeth of pinion gears and axle side gears), but apply equal torque to the two side gears. This drives both the rear wheels (half shafts) at the same speed and crown wheel, differential cage, cross pin, pinion gears and side gears all turn as a solid unit. Both half shafts rotate at the same speed and there is no relative movement among various differential gears.

When the vehicle is taking a turn, the cage continues to rotate and pull both the pinion gears around on the cross pin. The outer wheel must turn faster than the inner wheel and for this to happen

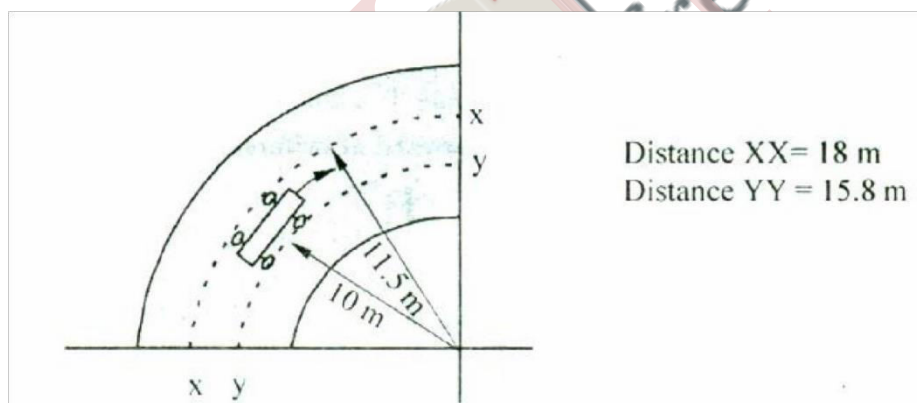
the outer axle side gear has to rotate faster than the inner axle side gear. To permit this, the two differential pinion gears rotate on their axes (on cross pin). This allows them to pull on both axle side gears, while at the same time, compensating for the difference in speed by rotating around their shaft.

The figure (c) shows the differential gears, when the vehicle is moving straight. The pinion gear is pulling both gears, but it is not turning. In figure (d), the right side axle gear is moving faster than the left axle gear. The pinion gear is still moving at the same speed and pulling on both gears, but started to turn on the cross pin. This turning action added to the forward rotational speed of the shaft and causes the right side gear to speed up and left side gear to slow down.

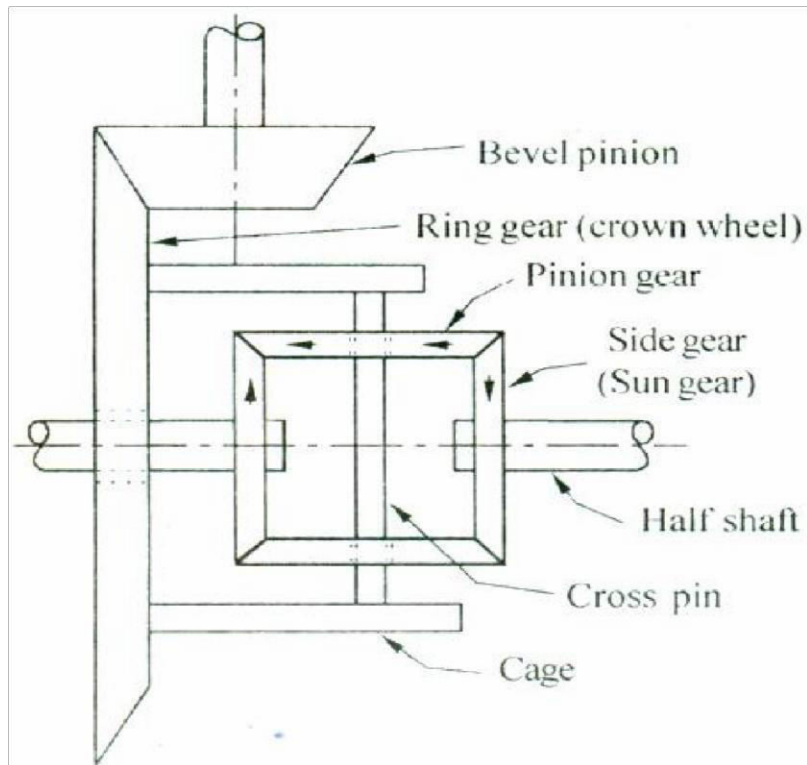
To understand how all this happens, assume that the cage is stationary. If we turn one side gear, it drives the other side gear in opposite direction. Suppose if left side gear rotates 'n' times in a particular time, this causes right side gear to rotate 'n' times in the same period, but of course in the opposite direction. This rotation is super imposed on the normal wheel speed when the car travels a curve.

As an example assume vehicle speed as say 'N' rpm, when it is going straight. When it turns right, there is a resistance to the motion of right wheel due to differential action and right side wheel rotates back by 'n' rpm, left side wheel rotates forward by 'n' rpm. Thus the resultant speed at the right wheel is (N-n) rpm, and this slow down the right wheel. The resultant speed at the left wheel is (N + n) rpm, causes the left to move faster.

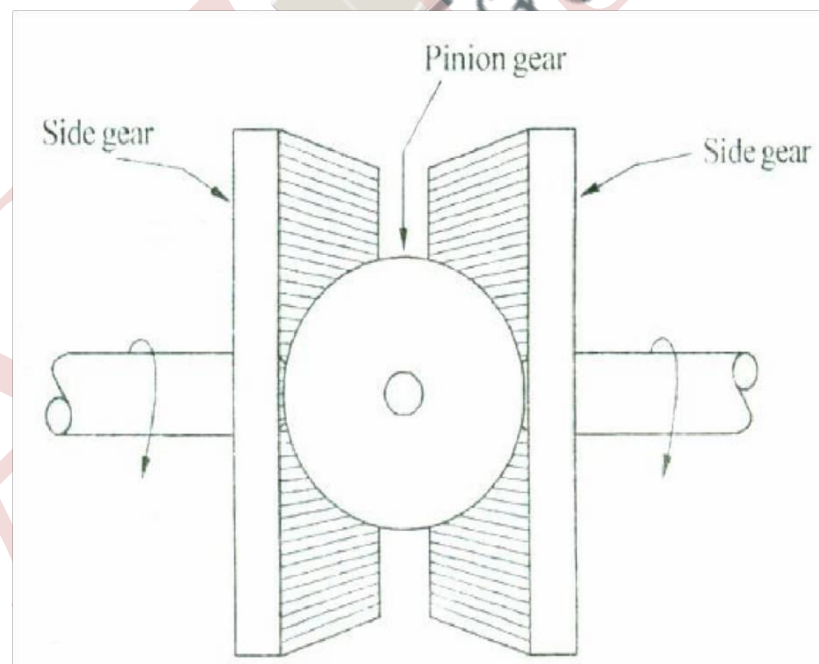
As the pinion gears are free to rotate on the cross pin, they act as balance and divide the torque equally between the two wheels.



**Fig (a): Distance travelled by inner and outer wheels when a car taking turn**



**Fig (b): Differential**



**Fig (c): Axle side gears, Pinion gear and shaft revolve as a unit, Straight line driving**



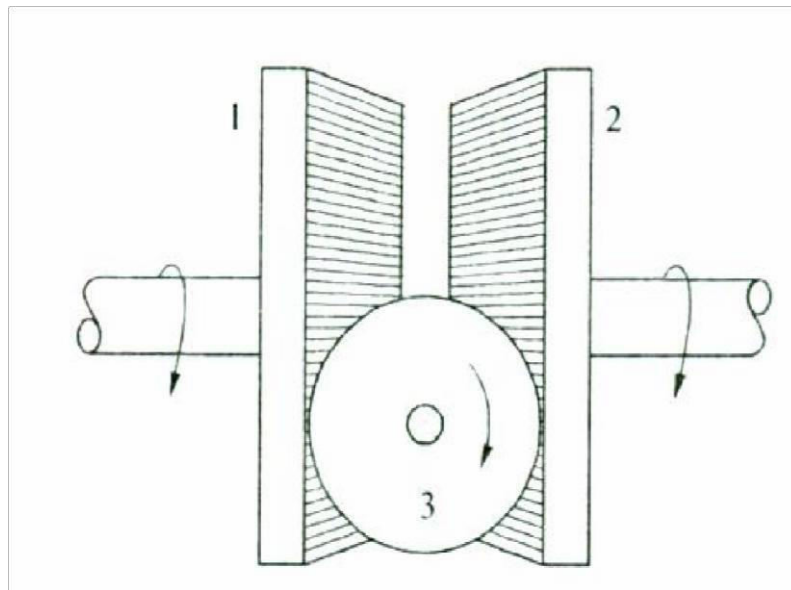


Fig (d): Axle side gear move forward at different speeds. Pinion gear (3) is turning

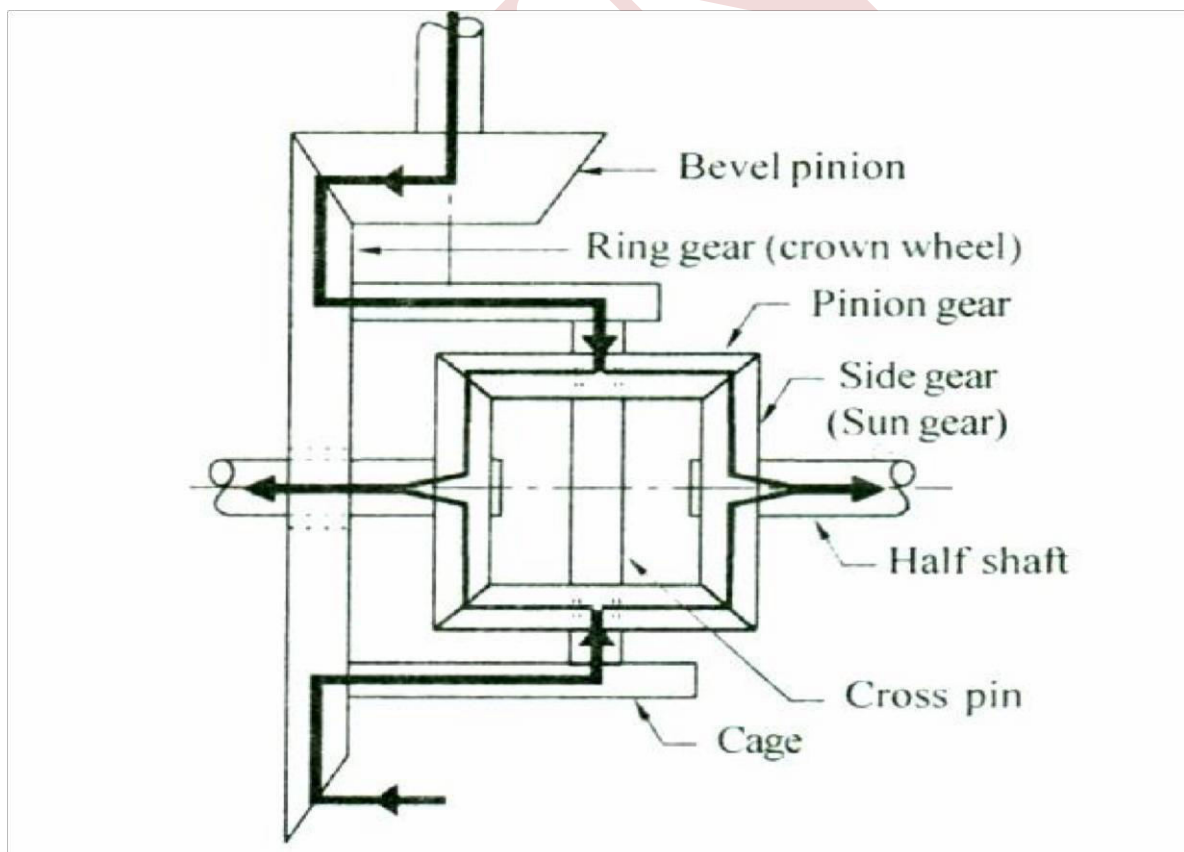


Fig (e): Power flow through nonslip differential on straight away .

## STEERING

It is necessary to run the automobile in a desired direction; this can be accomplished by providing steering system. Besides brakes and accelerator, steering is very much essential to control the vehicle, without which an automobile will never exist.

The main purpose of a steering system is to provide angular motion to the front wheels, when the vehicle is taking a turn. Different steering gears and linkages are used to steer the front wheels.

The purpose of a steering system is to convert rotary motion of the steering wheel in the driver's hands into angular motion of the front road wheels, and to multiply the driver's effort by leverage or mechanical advantage so as to make it fairly easy to turn the wheels. The steering system also absorbs large part of the road shocks, thus preventing them being transmitted to the driver.

Apart from the above object, the steering system also serves other purposes like,

1. It gives perfect steering condition. It means perfect rolling motion of road wheels under all conditions.
2. When the car is moving in a straight line, it gives directional stability.
3. To reduce tyre wear.
4. To facilitate straight ahead recovery after completing the turn.

The steering system has to fulfill the following requirements.

1. The system used should be very accurate and should be easy to handle.
2. The steering effort (for driver) should be minimum.
3. It must give directional stability.

Till recently front wheel steered vehicles were designed. In these vehicles front wheels were steered with rear wheels followed them. However, lately all-wheel steering or four-wheel steering has been designed and used in some selected vehicles.

### GENERAL ARRANGEMENT OF STEERING LINKAGES

Based on vehicle type i.e., a 'vehicle which has independent front suspension or a vehicle which has a rigid axle type front suspension (commercial car), different steering linkages are used.

#### Steering Linkage used in the Vehicle with rigid axle front suspension

It consists of a drop arm or pitman arm connected between steering gear and link rod. The link rod in turn connects steering arm through a ball joint and the stub axle mounted with road wheel is rigidly attached to the steering arm as shown in figure O. Each stub axle has a forged track rod arm rigidly fixed to the wheel axis. To the ends of track rod arms, a track rod is attached by using 'O' ball joints as in figure. An adjuster is also used in the track rod and it changes length of the track rod for adjusting wheel alignment.

The steering gear provides the required leverage (mechanical advantage), so that driver's effort required is less at the steering wheel to apply much larger force to the steering linkage. It also

gives the desired velocity ratio so that larger angular movement of the steering wheel gives much smaller movement of the stub axle.

By turning the steering wheel, drop arm swings and imparts a linear movement to the link rod. The steering arm transmits this movement to the stub axle, and turns it about pivot (may be a king pin or ball joints). The other wheel is steered through the track rod; hence only one wheel is positively steered.

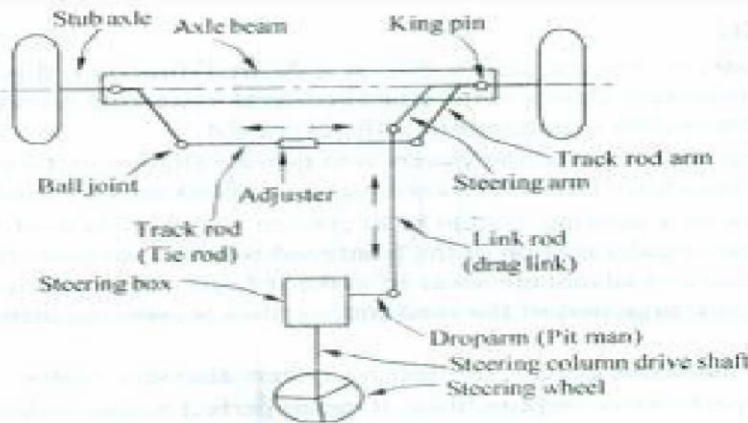


Fig. 6.10 Steering linkage for rigid axle suspension.

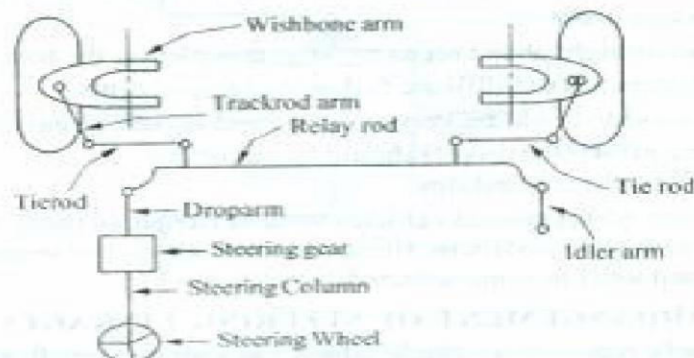


Fig. 6.11(a) Steering linkage for independent suspension.

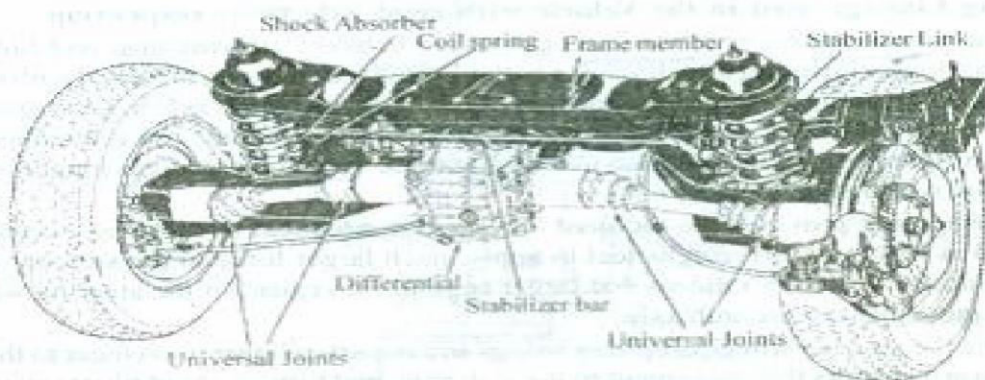


Fig. 6.11(b) Independent rear suspension.

### Steering Linkage used for Independent front suspension

In the previous type, the main axle beam allows the stub axle to move in the horizontal plane only. The effective track rod length does not change as there is no vertical deflection of the suspension.

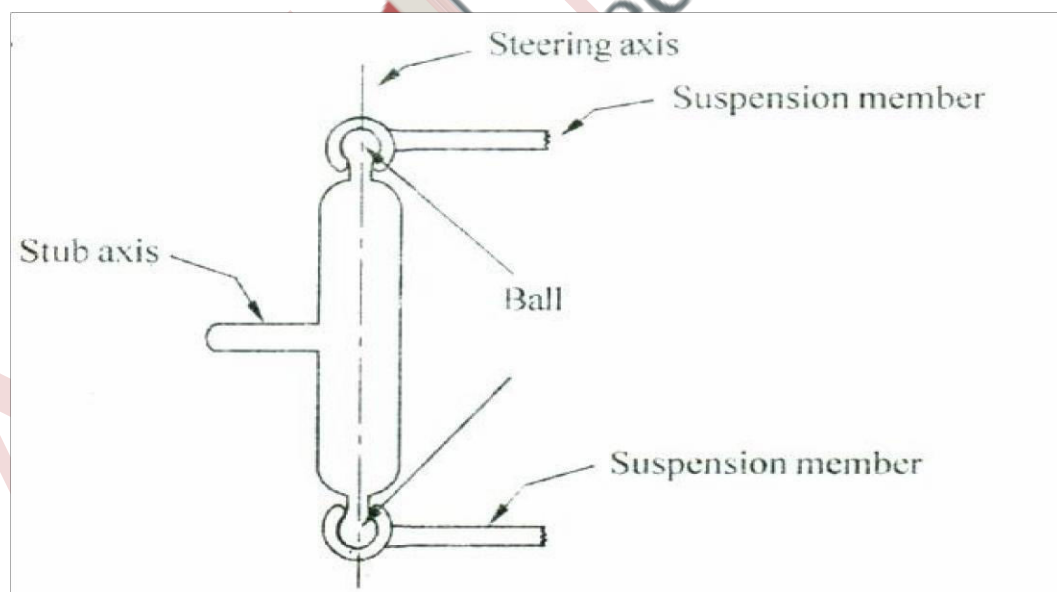
In the independent suspension, the two stub axles can move up and down independent of each other and causes the length of the track rod to change. For this reason, a single track rod is not suitable.

The arrangement consists of a three piece track rod, the centre being called relay rod, one end of which is connected to idler arm supported on body structure. The other end of the relay rod is connected to the drop arm of the steering gear through ball joints. The relay rod is confined to move in horizontal plane only. Movement in vertical plane is provided by the tie rods about the end ball joints.

### STUB AXLE

Stub axle is one on which the front road wheels are mounted. The king pin connects main axle beam to the stub axle. Stub axles are made up of Nickel steels and alloy steels containing chromium and molybdenum. Usually front axle is a dead axle and is manufactured by drop forging of steel. As it has to withstand bending loads due to vehicle weight and torque loads due to braking of wheels the central portions is made 'T' section and the ends of the beam are made either circular or elliptical. This dead front axle is used in heavier vehicles.

The figure shows the arrangement of the stub axle in which king pin has been replaced by ball joints.



**Fig: Stub axle arrangement with king ball joints**

### STEERING GEOMETRY

It is not enough to simply place the front wheels on hubs, stand them up straight and device a mechanism to swivel them left or right. The car could be driven but it would steer very poorly and at higher speeds it would become dangerous to handle, and also tire life would be short.

Wheel alignment refers to the positioning of the front wheels and steering mechanism that promotes easy of steering, provides directional stability, reduces tire wear to a minimum. To secure easy steering, smooth operation and several front wheel alignment factors must be considered such as camber, king-pin or steering axis inclination, caster, toe in and toe out and turning circles (angles) etc.

### (a) Camber

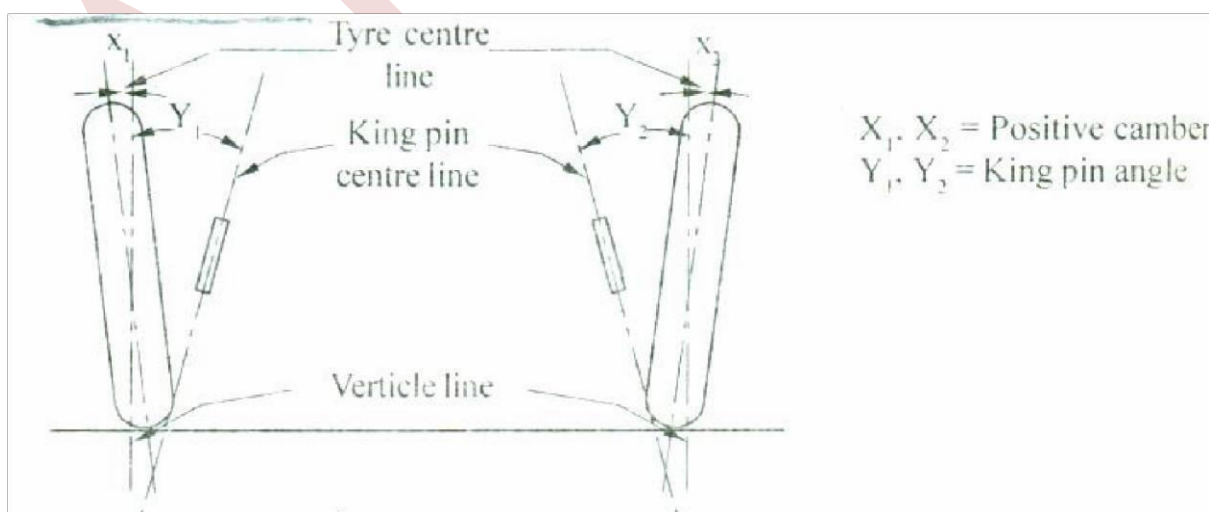
Camber angle is the inclination between the centre line of the tyre and the vertical. If the wheels are inclined or tilted outward at the top, it is called "positive camber", and if the wheels are inclined inward at the top, it is called "negative camber". It is also called as 'wheel rake angle':.

Front wheels are not mounted parallel to each other; instead they are tilted slightly outward at the top. This is done to prevent the top of the wheels from tilting inward too much due to excessive loads or play in the king pins and wheel bearings.

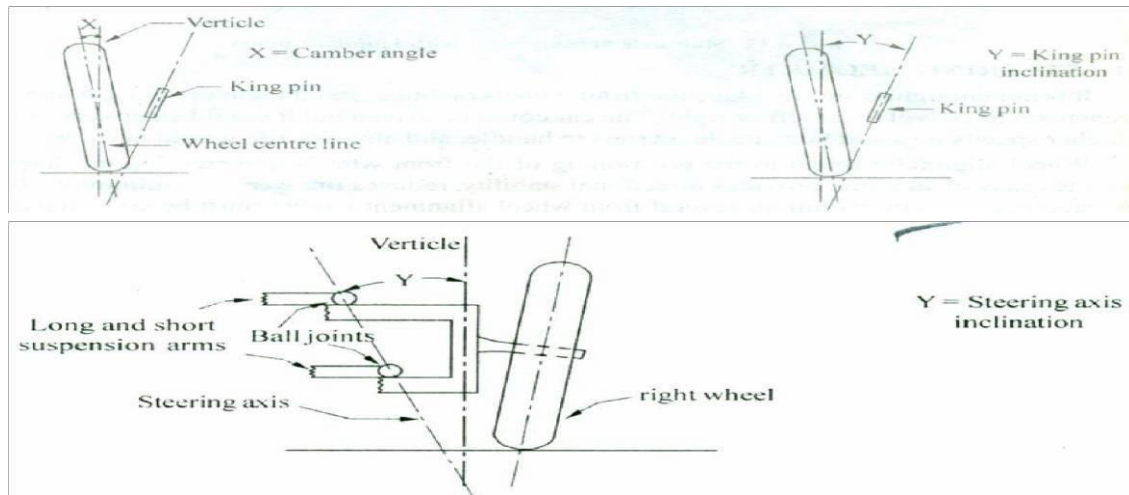
**Effect:** It is noted that, to make the tyre wear more uniform, tyre should roll vertically on the ground. Tyre will wear more on one side than the other side, when it is tilted inward or outward. The positive camber causes the tyre to roll like a truncated cone. The positive camber makes the wheel to toe out and tyre will wear more on the outer side. Similarly the negative camber makes the wheels to toe in and tyre will wear more on the inner side. Initially the wheels are provided with positive camber, after loading automatically they come to vertical position.

It is clear that, when the vehicle is running with average load, zero camber angle gives maximum tyre life. If the two front wheels are not provided with equal camber, the vehicle will try to pull towards the side where the camber is higher. In the same way, if the wheels are provided with equal camber, the crowned road has a tendency to pull away the vehicle to the side of the road. To obviate this, usually slight higher camber is provided on the right wheel in case of right drive vehicles which have to move on the left side. For left hand drive vehicles, left wheel is sided with higher camber.

Camber angle is usually less than  $2^\circ$  and exact amount depends upon king pin inclination.



**Fig (a): Camber and king pin inclination**



**Fig: Camber and king pin angle (steering axis inclination) on exaggerated scale.**

### (b) Kingpin angle or Steering axis inclination

The kingpin or Ball joints are mounted in such a way that they slant inward. The kingpin inclination is the inward tilt of the kingpin or ball joint centre line from the vertical i.e., the angle between vertical and kingpin or ball joint centre line]. In case of kingpin, this is called king pin angle and if ball joints are used, then it is called steering axis inclination.

**Effect:** Kingpin inclination in combination with caster provides directional stability. When the vehicle turns, the vehicle body is lifted up slightly due to kingpin inclination. After completing the turn, driver leaves the steering wheel and vehicle weight causes the wheels to recover straight ahead position. The kingpin angle is kept about  $7^{\circ}$  to  $8^{\circ}$  and exact amount depends upon wheel rake angle. This kingpin angle also; uses suspension shocks to be transmitted to and absorbed by the heavy inner spindle and knuckle assembly.

### (c) Included angle and Scrub radius

It is the angle obtained in the vertical plane between the wheel centre line and the king pin or ball joint centre line. It is equal to camber plus king pin inclination ( $X + Y$ ).

The king pin centre line when extended meets the road surface near the tyre centre line. The distance between these two centre lines at the point where they intersect on the road surface is called "Scrub Radius". It is positive when steering axis or ball joint centre line meets the road surface inside the tyre centre line. If it meets the road surface outside the tyre centre line, the scrub radius is negative. A small scrub radius is desirable as it reduces steering wheel shock from road irregularities and reduces steering effort.

**Effect:** The figure explains, how the combined angle affects scrub radius and hence' forces acting to turn the wheel in a rear wheel drive vehicle. It is seen that unless scrub radius is zero, a torque acts to turn the wheel away from the straight ahead position.

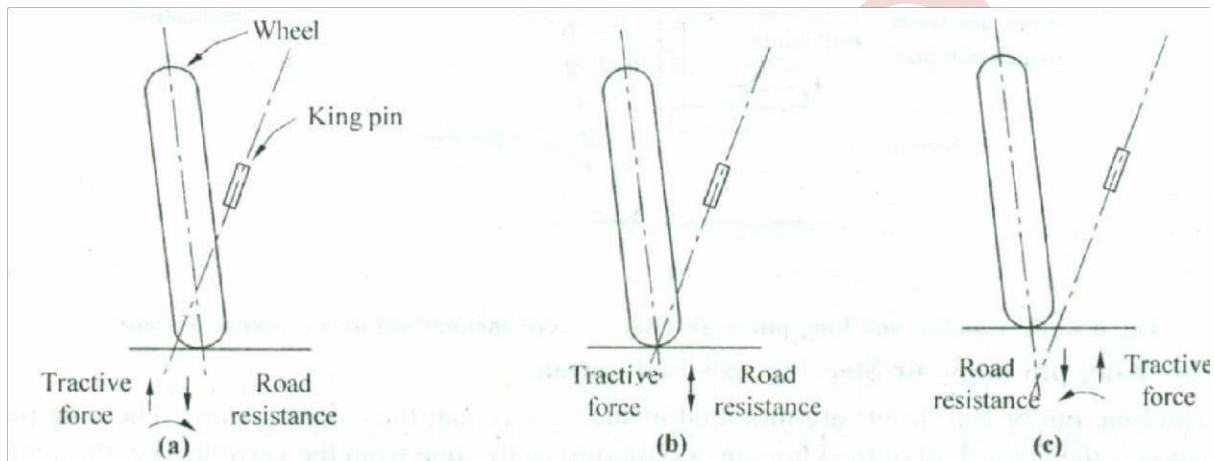
A negative scrub radius causes the wheel to toe in as in figure (a). A positive scrub radius causes the wheel to toe out as in figure (c)

A zero scrub radius keeps the wheel in straight position without any tendency to toe in or toe out as in figure (b). In this case, wheel centre line and king pin or ball joint centre line exactly meets on the ground. This condition is called "centre point steering".

By experience, it has been proved that, if the ball joint centre line and wheel centre line meets below the ground, it gives best results.

If both the wheels are not provided with equal combined angle, the vehicle will pull towards the side where scrub radius is high.

Combined angle varies from  $9^{\circ}$  to  $10^{\circ}$  and scrub radius ranges up to 12 mm.



**Fig:** The wheel and king pin centre line meet (a) above the ground (negative scrub radius) - wheels toe in (b) Exactly on the ground (zero scrub radius - 0 effect) and (c) below the ground (positive scrub radius) - wheels toe out

#### (d) Castor

The kingpins are tilted slightly from the vertical as shown in figure 6.15 (a) and (b). The angle between the kingpin centre line and vertical, obtained in the plane of wheel is called the castor angle. If the kingpin centre line contacts the ground at a point in front of the wheel centre, it is called Positive Castor and if it meets behind the wheel centre line it is called Negative Castor. The castor angles should not exceed  $3^{\circ}$ . In modern vehicles negative castor ranges from  $2^{\circ}$  to  $8^{\circ}$ .

**Effect:** Castor produces a trailing effect and hence gives directional stability by making the wheels to lead or follow in the same direction as the vehicle moves. Incorrect castor angle results in hard steering, when brakes are applied vehicle pulls to one side, tendency to wander due to lack of directional stability.

**Example:** Castor angle provided on the furniture rollers and on the front wheels of the bicycles, the positive castor provided in both these cases causes the wheels to be pulled in any direction.

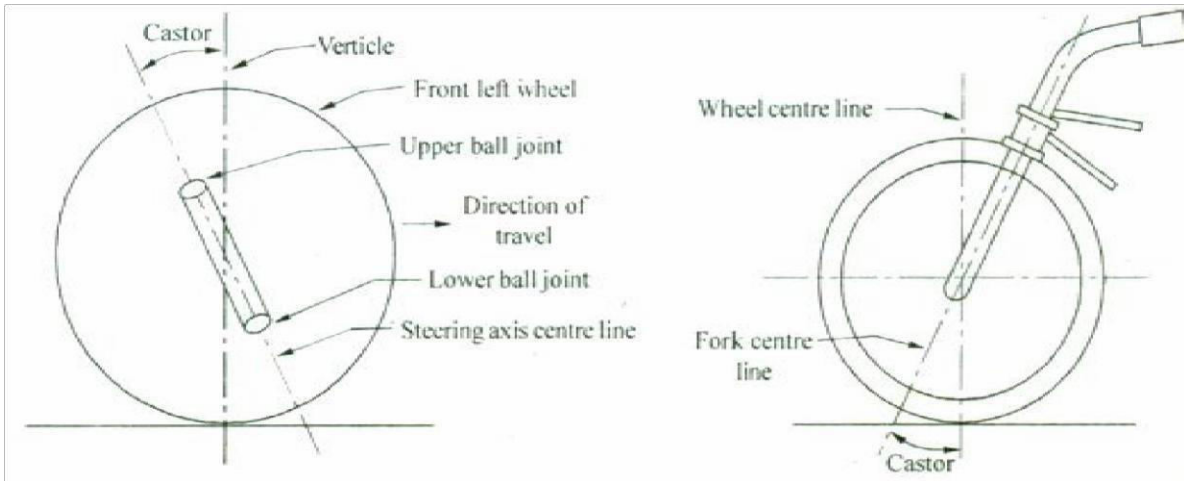


Fig: (a) Castor; (b) Castor on front wheel of the bicycle.

**TOE IN AND TOE OUT CONDITIONS**

Toe in is accomplished by placing the front of the wheels closer together than the back, when viewed from the top and vehicle is stationary. Toe in is nothing but the difference between the centre to centre distances of the rear ends and the front ends i.e.  $(B - A)$

If the wheels are set closer at the back end than at the front, i.e.  $(A - B)$ , then the difference of distances between the wheels at the front and at the rear is called Toe out.

**Effect:** When the wheel is cambered, the tire engages the road at an angle. Since the tire will adopt itself to the road, the rolling edge of the tire will not be at right angles to the centre line of the wheel. This will cause it to roll in the form of truncated cone and thus causes more wear on outer surface of the wheel, the purpose of toe in is to neutralize the cone rolling effect of front wheels caused by camber angle. Therefore, the amount of toe in depends up on the camber angle, and in modern cars it is usually kept 2 to 4 mm.

In some front wheel drive cars, initial toe out has been provided to counter the tendency to toe in. Excessive steering linkage looseness will allow the wheels to toe out under dynamic loads. Excessive toe in or toe out will cause tyre wear.

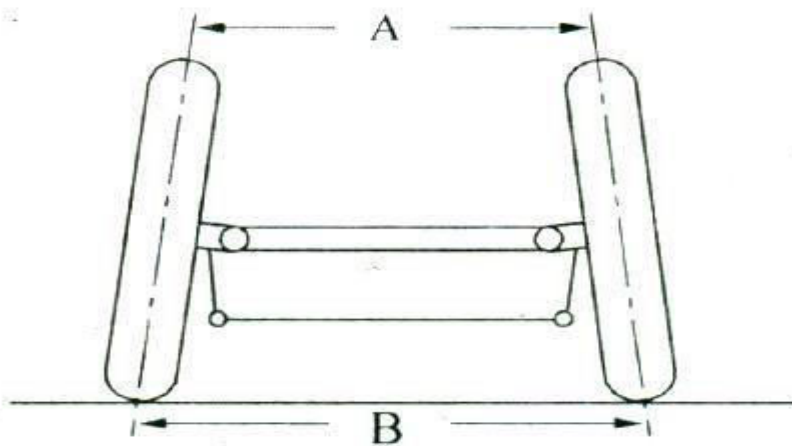


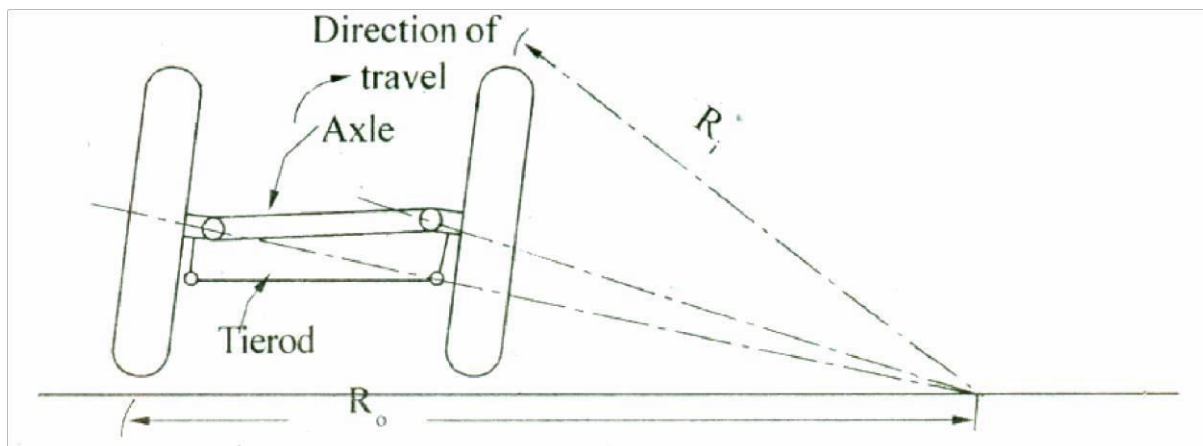
Fig: Toe - in



### TOE OUT ON TURNS

When a vehicle takes a turn, the inner wheel must turn on a smaller turning circle than the outer wheel. This causes the wheels to toe out on turns due to difference in their turning angles. ∴ This essential action is allowed by bending both steering arms so they angle slightly towards the centre of the vehicle.

When the vehicle takes turn, the steering arm on the inside of the turn swivels more sharply, due to angle of the arm at this point.



**Fig: Toe out on turns as viewed from top**

### STEERING GEARS

Steering gear is the heart of steering system and the driver controls the direction of front wheels with the steering gear. It converts rotational motion of the steering wheel into to and fro motion (arc motion) of the link rod of the steering linkage which in turn swivel the front wheels.

Steering gear also provides torque multiplication. It multiplies the driver's steering effort to provide adequate force for steering column. For cars, the steering ratio or torque multiplication factor ranges between 10 : 1 to 22 : 1 and for trucks it ranges between 24 : 1 to 32 : 1.

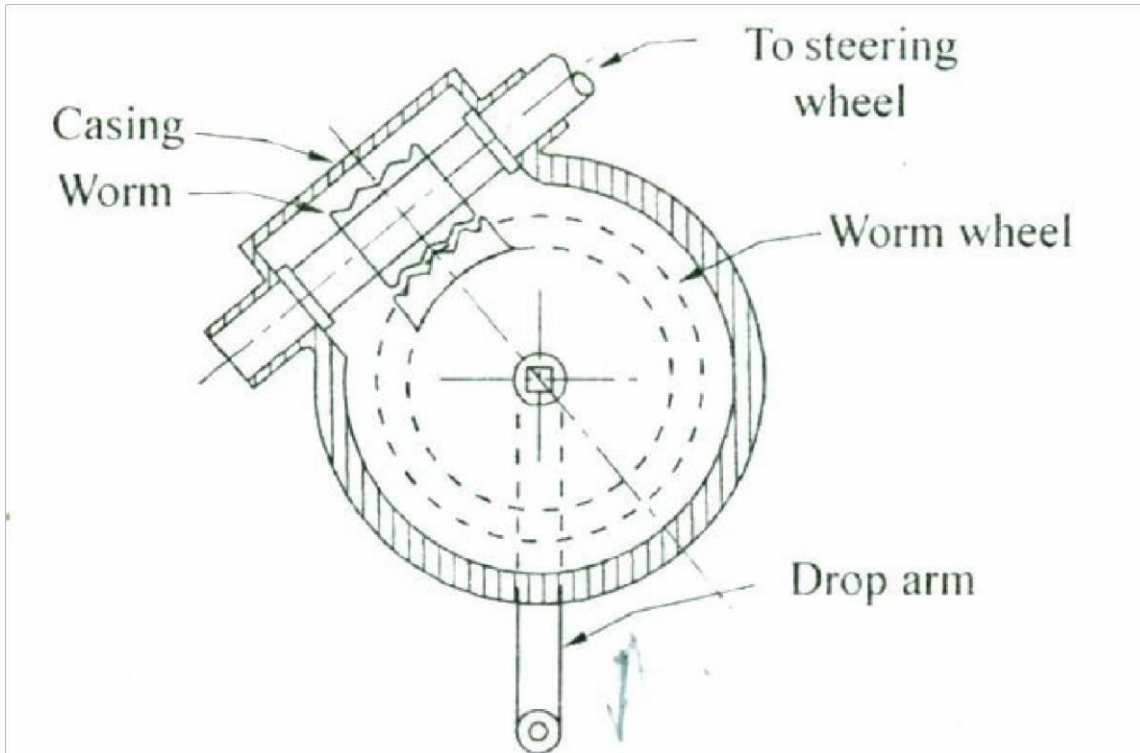
There are many types of steering gears used in automobiles. The important steering gears are

#### a) Worm and Wheel steering gear

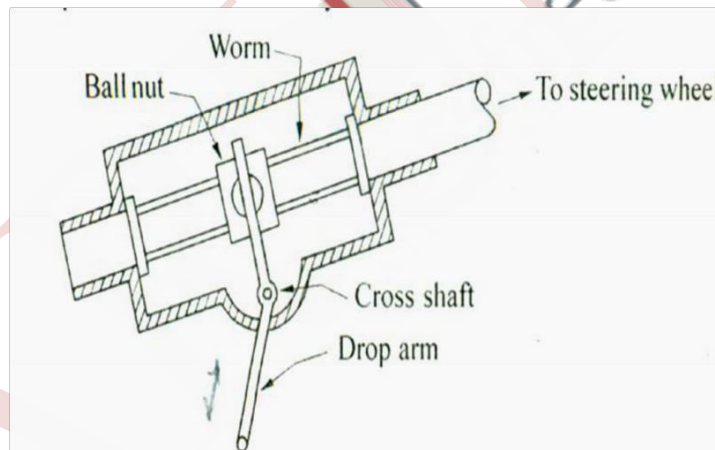
It consists of a worm and worm wheel. In place of worm wheel, only a sector may also be used. As the steering wheel turns, the rotation of the worm drives the worm wheel. A drop arm is rigidly attached to the wheel spindle. So rotation of worm wheel through steering wheel causes the drop arm to move to and fro, thereby, actuates the link rod connected to it and swivels the front wheels.

#### b) Worm and Nut steering gear

It consists of a worm and a ball nut and these are arranged as shown in figure. The rotation of steering wheel turns the worm and hence the nut moves along its length. This movement of the nut actuates the drop arm end to move linearly and thus actuates the link rod and swivels the wheels.



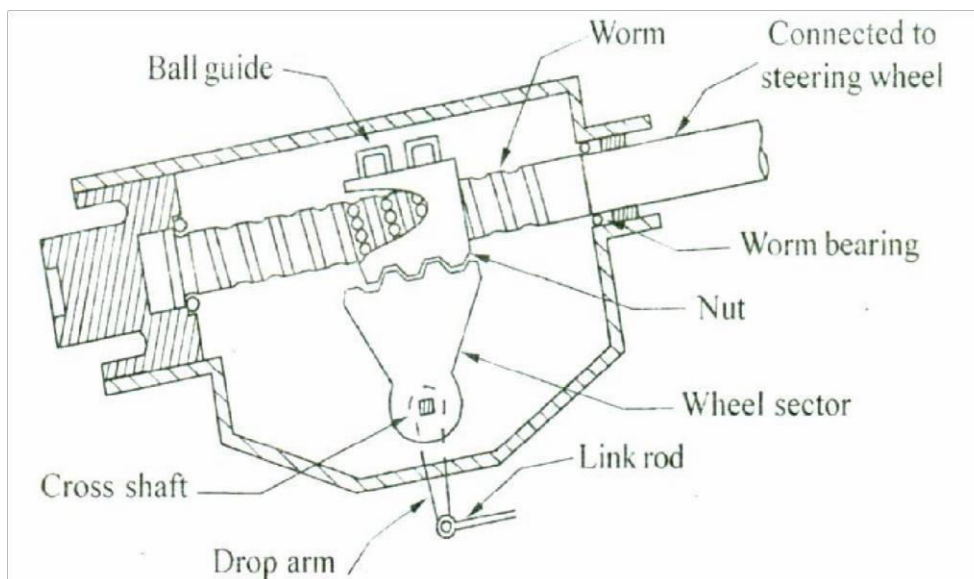
**Fig: Worm and wheel steering gear.**



**Fig: Worm and out type steering gear.**

**c) Recirculating ball type steering gear**

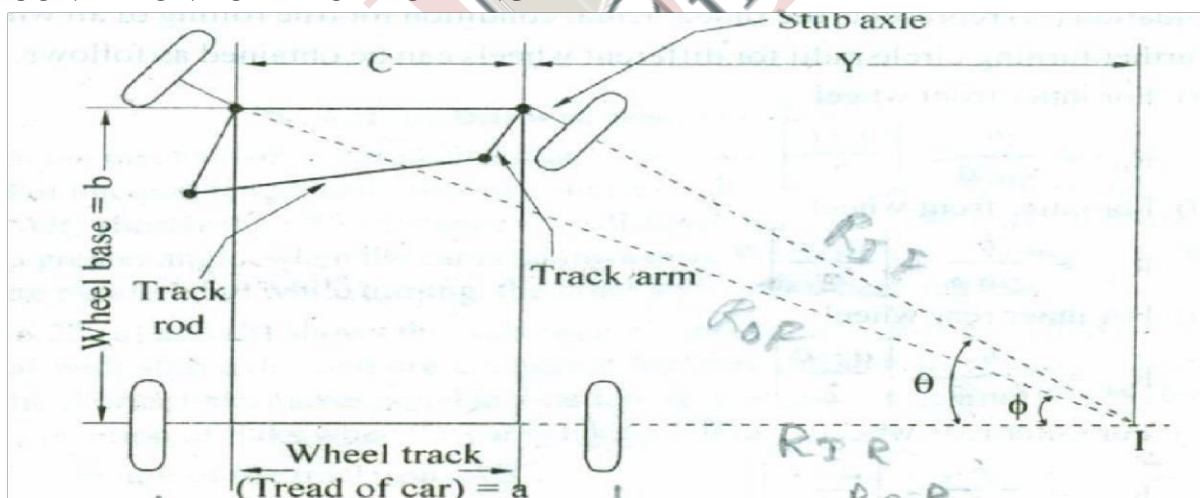
The figure shows a recirculating ball type steering gear. It consists of a worm and nut arrangement as in figure. The steering shaft carries the worm and a nut rides on the worm with two sets of balls in the grooves in between nut and worm. These balls reduce friction during movement of the nut on the worm. The drop arm is rigidly attached to the wheel sector and the teeth of wheel sector meshes with teeth of the nut. The drop arm in turn connected to the link rod, through which it swivels the road wheels.



**Fig: Recirculating ball type steering gear.**

When the steering wheel is turned, the nut rides on the worm and the balls roll in the groove and makes the nut to travel along the length of the worm. These two sets of balls are recirculated through the guides. As the nut rides on the worm, its movement drives the wheel sector and hence link rod and thus steers the wheels.

**CONDITION FOR TRUE ROLLING**



**Fig: Condition for exact steering**

The condition for true rolling is obtained when all four wheels are rolling perfectly under all conditions of running. If the vehicle takes a turn, this fundamental condition of correct steering is satisfied when all four wheels rotate about a common centre called as Instantaneous centre. The axes of front wheels when produced meet the rear wheel axis at this point 'I'. It is also seen that, the inside wheel turns through a greater angle than the outer wheel. The larger the steering angle, the smaller is the turning circle. However, there is maximum limit to the steering angle, and is limited to  $44^\circ$ . The extreme positions on both sides are called 'Lock' positions.

The turning circle is defined as the diameter of the smallest circle which the outer front wheel of an automobile can traverse and obtained when the wheels are at lock positions.

**STEERING MECHANISM**

We know that for perfect steering all four wheels must rotate about Instantaneous centre. To achieve this, inner wheel has to turn more than outer wheel. Several mechanisms are used, among which two are important.

1. Ackermann Mechanism
2. Davis Mechanism.



The Ackermann mechanism is based on a four- bar chain mechanism, which has two longer links RS and AB of unequal length and other two shorter links 'RA' and 'SB' of equal lengths. By using track rod 'AB' shorter than RS (distance C or distance between kingpins), the inner wheel is forced to turn a greater angle, when the car is taking a turn. When the car is going straight ahead, all four wheels are parallel, but while turning, the inner and outer wheel angles become different.

The figure (a) and (b) shows the Ackermann's mechanism. It is seen that shorter links are made integral with stub axles and are connected together through track rod. In the straight ahead position, the shorter links makes equal inclination 'a' with the centre line of the vehicle. The dotted line shows position of links when the car is taking left turn.

Let, **I** = length of the track rod 'AB' and **r** = Length of shorter links RA and SB.

From figure (b), after neglecting obliquity of link AB in the turned position, the pivots A and B moves through same distance 'X' in horizontal direction.

Then from figure 5.22 (b)

$$\sin (\alpha + \theta) = \frac{y + x}{r} \quad \dots (A)$$

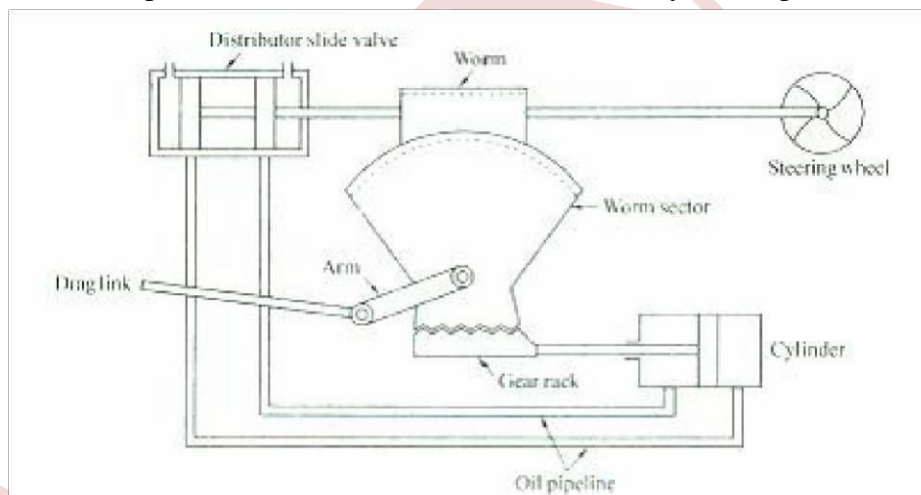
$$\sin (\alpha - \phi) = \frac{y - x}{r} \quad \dots (B)$$

(A) + (B) gives\*

$$\sin (\alpha + \theta) + \sin (\alpha - \phi) = \frac{2y}{r} = 2 \sin \alpha.$$

### POWER STEERING

In heavy duty trucks and tractors, driver has to apply inadequate effort to turn the wheels. The use of booster arrangement in steering system overcomes this drawback. The booster is put in to operation when the steering wheel is turned. It does most of the work for steering. The power steering system uses compressed air, electrical mechanisms, and hydraulic pressure.



**Fig: Oil assisted power steering**

The figure shows a simplified diagram of hydraulic booster. The arrangement consists of a worm and worm-wheel, distributor slide valve, booster cylinder etc. When the steering wheel is turned, the worm turns the sector of worm wheel and hence actuates the arm. The arm in turn actuates the road wheels through drag link. If the resistance offered to turn the wheels is too high and driver's effort to the steering wheel is too weak, then the worm, like a screw in a nut will be displaced axially together with the distributor slide valve. This axial movement will admit compressed air or oil in to booster cylinder through the pipeline. The piston in the booster cylinder will turn the road wheels via the gear rack, the toothed worm sector, arm and drag link. In the mean time, the worm sector will actuate the worm and will shift it along with distribution slide valve to its initial position. This movement of slide valve will stop the piston travel in the booster cylinder. Here the system uses power assistance in proportion to the effort needed to turn the wheels.

## CHASSIS FRAME

In an automobile, frame is the foundation part which supports the power plant and body.

The frame itself is supported on the road wheels through axles and springs.

The engine, wheels, power train, brakes and steering systems when installed on the frame, the assembly is called chassis. The chassis can be driven by the driver on the road safely.

The main functions of the frame are

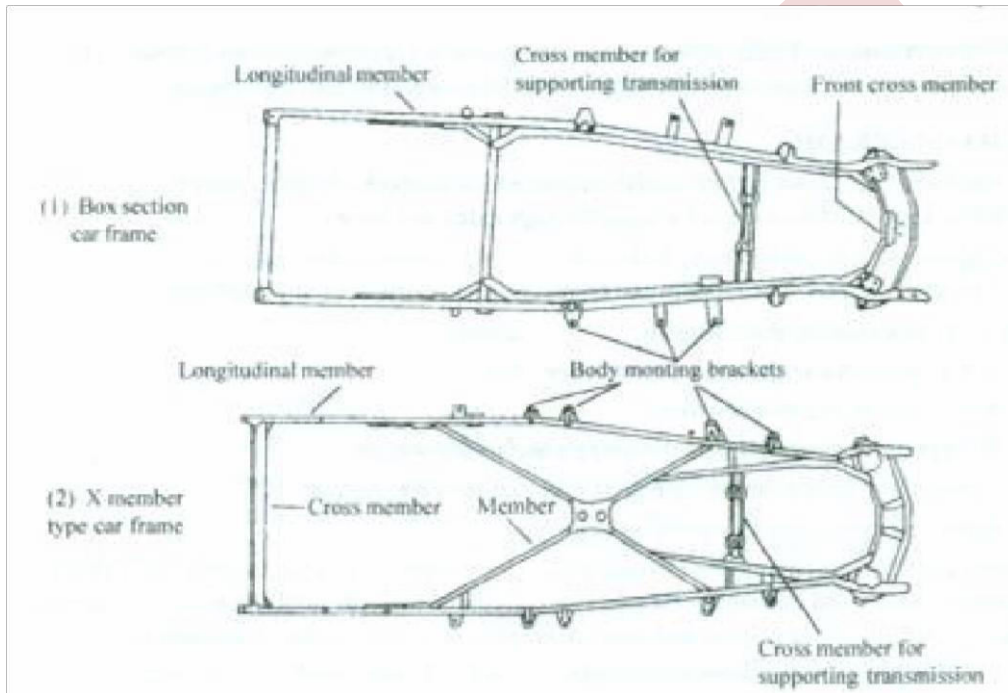
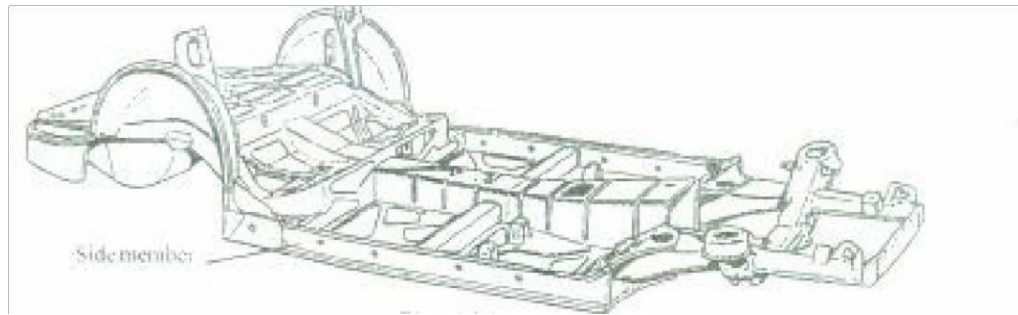
1. It with stand the engine and transmission thrust.
2. It with stands the torque stresses.
3. To support body weight, passengers and goods weight.
4. It provides base for mounting engine and transmission systems.
5. It provides the space for spring system.

Frames are made of channel or U shaped sections welded or riveted together. It withstands the road shocks, twists and vibrations. Generally it consists of two side rails (longitudinal members) a variable number of cross members and also an X member. The side rail has a channel section, with the open side turned inward. These have maximum depth at their centers and tapering towards their ends. Straight longitudinal members are used in truck and bus frames. In motor cars, the side rails are given an arc shape both in front and rear and are referred as the double drop type. This makes the floor of the car body to come closer to the ground.

The chassis frame with box section side members (a typical car frame), box section type and X member type is as shown in figure.

At the front end, the frame is narrow to facilitate short turning radius of the front wheels. The frame widens out at the rear so as to provide ample space in the body for passenger accommodation. The side members are curved upward at the rear forming a kick up. The rear leaf springs connect each end of this curve. This type of frame is designed for independent front wheel suspension and is heavy in construction. The light weight cars have frame without diagonal (X) cross members. In others types, frames uses a single X frame with no side members.

The cross members used in vehicle frame increases the rigidity and to with stand shocks, blows, twists and vibrations, when the vehicle moves on a rough road and also during acceleration, braking and steering to one side.



**Fig: Chassis Frame**

**UNIT - 7****SUSPENSION & SPRINGS****INTRODUCTION**

The ability of vehicles to negotiate rough roads and handle well at high speeds is mainly due to proper design of suspension system. If the axles are bolted directly to the body, any uneven spot in the road would transmit adjoining force to the vehicle which in turn results in discomfort for riding. Hence the automobile chassis is mounted on the axle through springs. This is done to isolate shocks on the vehicle body from road. The parts which perform the function of isolating the vehicle from road shocks are called suspension system.

The main objectives of the suspension system are:

1. To prevent the road shocks from being transmitted to the vehicle parts, thereby providing suitable riding and cushioning effect to the occupants.
2. Reduces wear on the tyre.
3. To keep the vehicle stable while in motion by providing good road holding during driving, cornering and braking.
4. Provides safe vehicle control and free of irritating vibrations.

**REQUIREMENTS**

1. **Vertical vibrations and pitching:** The damper present in suspension system eliminates the vibrations caused due to striking of front wheel to a bump. However, rear wheel also experiences similar vibrations as it reaches the bump after some time and this depends on wheel base and vehicle speed. There are three possible relations of front and rear suspension frequencies.

- (i) Front frequency higher than the rear - After the initial vibration i.e., after one or two vibrations the maximum amplitude occurs.
- (ii) Front frequency equal to rear - The amplitude collapses throughout, though pitching tendency still exists
- (iii) Front frequency lesser than the rear - Practically there is no pitching tendency.

So, it is clear that in order to reduce pitching tendency of the vehicle, the (iii) condition is suitable.

2. **Rolling:** The centre of gravity of the vehicle will be at certain height above the ground level. A turning couple about the longitudinal axis of the vehicle will be induced during cornering because of the centrifugal force acting at C.G. and forces at tyre - road contact surface. This result in a motion called rolling. The manner in which the vehicle is sprung determines the axis about which the vehicle will roll.

3. **Brake dip:** When the brakes are applied, the vehicle nose has a tendency to be lowered or to dip.



This in turn depends up on C.G position relative to the ground, wheel base, and other suspension characteristics

**4. Unsprung weight:** When the wheels hit a bump, they vibrate along with the unsprung parts which store the vibration energy and transmit it to the sprung parts through the springs. When the weight of unsprung parts is greater, it increases energy stored due to vibrations and thus transmits greater shocks to the sprung parts. Therefore it is necessary to keep the unsprung weight as low as possible.

### TYPES OF SUSPENSION PRINGS

#### 1. Steel springs

a) Leaf spring b) tapered leaf spring c) coil spring d) torsion bar

#### 2. Rubber Spring

a) Compression spring b) compression - shear spring c) Steel reinforced spring d) progressive spring e) Face shear spring.

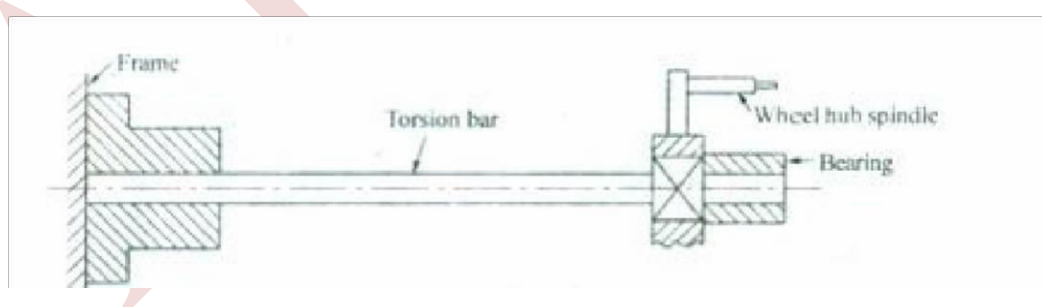
#### 3. Air springs

a) Bellow type b) piston type.

### Torsion bars

It is a simple rod which is acting in torsion and takes stresses only. It nearly stores the same amount of energy per unit weight as that of coil spring. Torsion bar is often used with independent suspensions.

When compared with other systems, it is lighter and occupies less space. Torsion tubes may also be used instead of torsion bars. One end of torsion bar is fixed to the frame, while the other end is fixed to the end of the wheel arm the supported in bearing. The wheel arm is connected to the wheel hub when the wheel hits a bump; it starts vibrating up and down and produces a torque on torsion bar, which acts as a spring.



**Fig: Torsion bars**

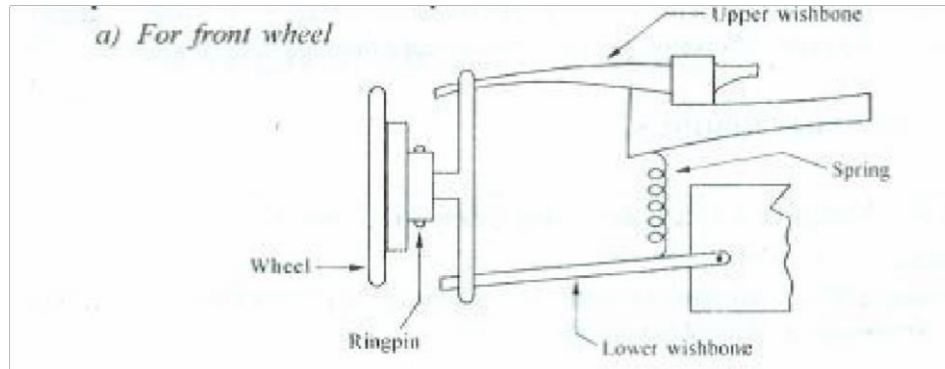
The two disadvantages associated with the use of torsion bar are.

- (i) It does not take braking or driving torque. This necessitates the use of additional linkages for the same purpose.
- (ii) No friction force exist, no damping and hence no control of vibrations produced due to road shocks.

## TYPES OF FRONT WHEEL SUSPENSION

There are two types:

1. Rigid axle free wheel suspension.
2. Independent front wheel suspension.

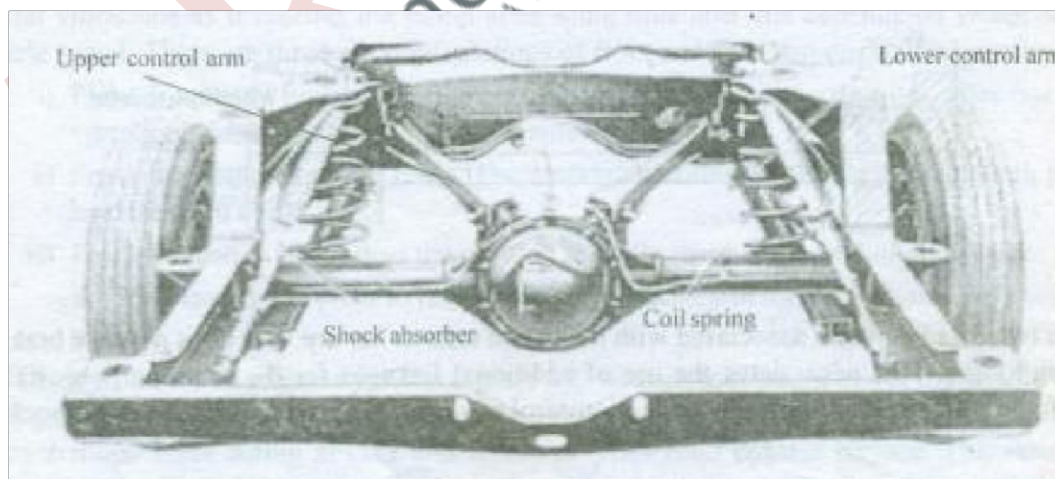


**Fig: Independent front wheel suspension**

In Independent suspension each front wheel is supported by a coil spring and a torsion bar. The independent suspension is confined only to the front wheels in the majority of vehicles because of its high cost. The independent front system has the following advantages.

1. It provides more space for the engine.
2. It provides softer suspension.
3. It reduces the tendency of wheels to turn about the king pin axis due to gyroscopic action.
4. It also reduces the tendency of tilting the vehicle on one side when the vehicle is lifted or dropped due to uneven road surface.

## b) Rear Suspension



**Fig: Coil spring rear suspension system.**

In rear suspension systems the coil springs and leaf springs are extensively used. Fig. illustrates a typical suspension system utilizing coil springs. The rear axle housing is mounted on springs and is attached to a set of upper and lower control arms. Universal Coupling shown

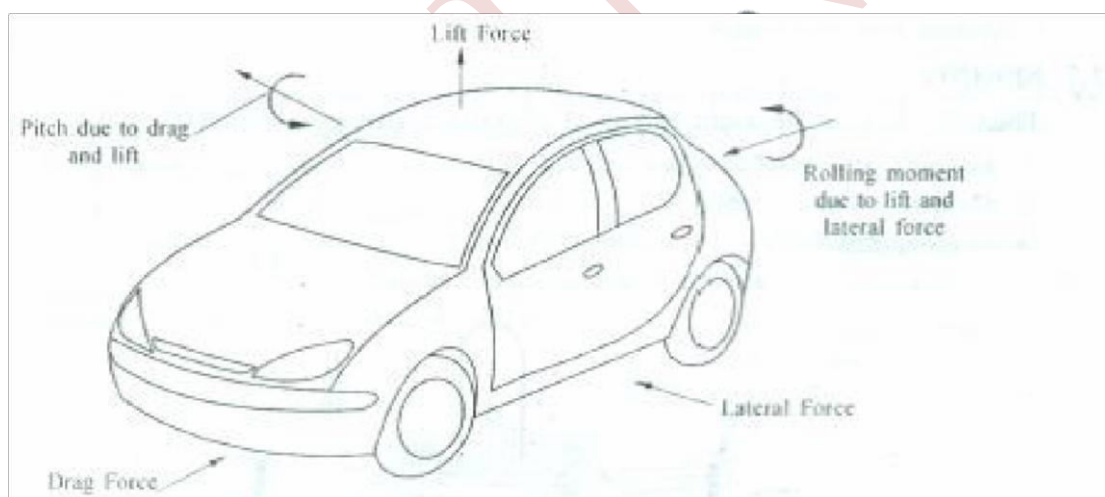
(represented in fig. by A & B, keep the wheel vertical and the sliding coupling "C" maintains the wheel track constant. This method is used in Dedoin type of axle, the control arm pivot points are rubber bushed. One end of the arm is connected to housing and the other to the frame. The arm arrangement allows the rear axle housing to move up and down, but prevents excessive Fore and Aft and side-to-side movement.

The main disadvantages are

1. Ignition lost is high.
2. As there is large number of parts, maintenance required is more.
3. The steering geometry is misaligned with the wear of component.

### PITCHING AND BOUNCING

The centre of gravity of the vehicle will be at certain height above the ground level. A turning couple about the longitudinal axis of the vehicle will be induced during cornering because of the centrifugal force acting at C.G and forces at tyre-road contact surface. This result in a motion called rolling. This causes the left hand suspension move out of phase with the right hand suspension. The tendency of the front portion (Nose) of the vehicle to dip due to braking is known as Brake Dip.

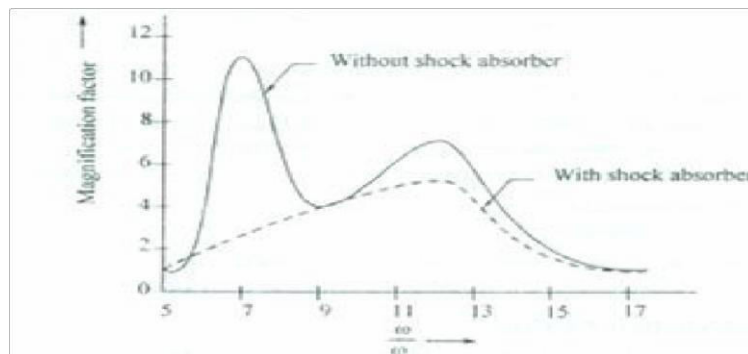


**Fig: Vehicle with different forces acting on it.**

In Figure are shown the different types of the spring mass motions. Pitching is the rotary motion about the transverse direction through the vehicle parallel to the ground. This causes front suspensions to move out of the phase with the rear.

Bouncing is the motion of centre of gravity in the vertical direction. It can be front end or rear end bounce. Diagonal pitching is the combination of pitch and roll.

## CONFERT CURVES



**Fig: Confert curves**

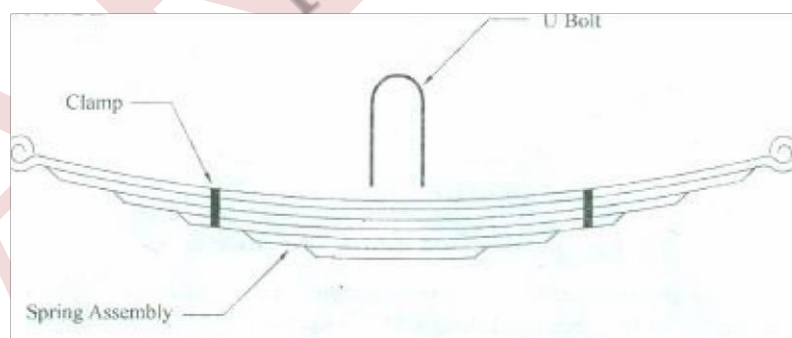
The graph shown is known as confert curves and gives us an idea of variation of amplitude of vibration with and without the use of shock absorber.

\* **Magnification factor is the ratio of maximum displacement of the forced vibration to the deflection due to the static force in a system.**

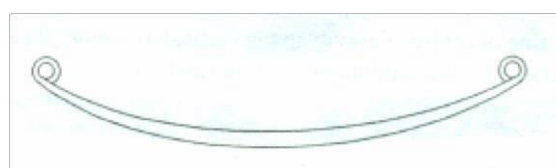
## SPRINGS

The following are the commonly used suspension springs in Cars and Trucks.

1. Leaf or Laminated Springs.
2. Helical or Coil springs.
3. Torsion Bar
4. Rubber or elastic springs.
5. Hydro elastic springs.
6. Air springs.



**Fig: Semi elliptical leaf spring**



**Fig: Long, wide and quite thin. Entire spring is made up of one leaf.**

## 1. Leaf or Laminated Springs

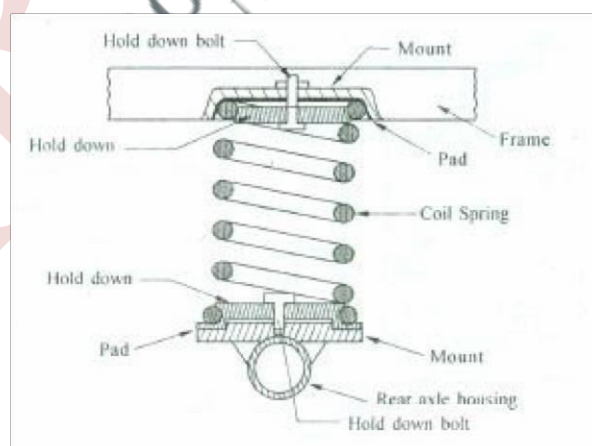
The leaf springs are made up of steel plates of leaves as shown in fig. These are commonly used in automobile rear suspensions. The leaves are held together at centre by a bolt which passes through holes in the leaves. Many leaf springs have special inserts between the leaves to permit the leaves to slip over one another when the spring bends. The spring leaves are of graduated length as shown; the front end of the largest leaf is bent into a circle to form a spring eye and is attached to the spring hanger by a bolt. Rubber bushings are used to provide the insertion to the bolt from the spring hanger. The rubber bushings serve two purposes.

- a) Absorb vibration and thus prevent it from getting up to the vehicle frame.
- b) Allow the spring eye to twist back and forth as the leaf spring bends.

The rear end of the spring is also bent to form a spring eye. This spring eye is attached to the car frame through a spring shackle. The shackle allows for changes in the length of the leaf spring as it bends. As when the springs pushed upward or downward by bumps or holes in the road, the distance between the two spring eye changes. The shackle acts as a swinging support that permits this change in length.

## 2. Coil Springs

Nowadays coil springs have become very popular because of the limitations involved in leaf spring. Fig shows a front suspension system using coil springs. In the system shown, the coil spring is held between a spring seat in the car frame and a lower control arm. The inner ends of control arms are pivoted on the car frame, the outer ends are connected to the steering knuckle. This in turn is attached to the control arms. The ball joints used to allow the steering knuckles to swing to the left or right for steering. In the assembled car, the wheels are mounted from left to right pivots the front wheels, so that the car can be steered.



**Fig: Coil Spring.**

## SHOCK ABSORBERS

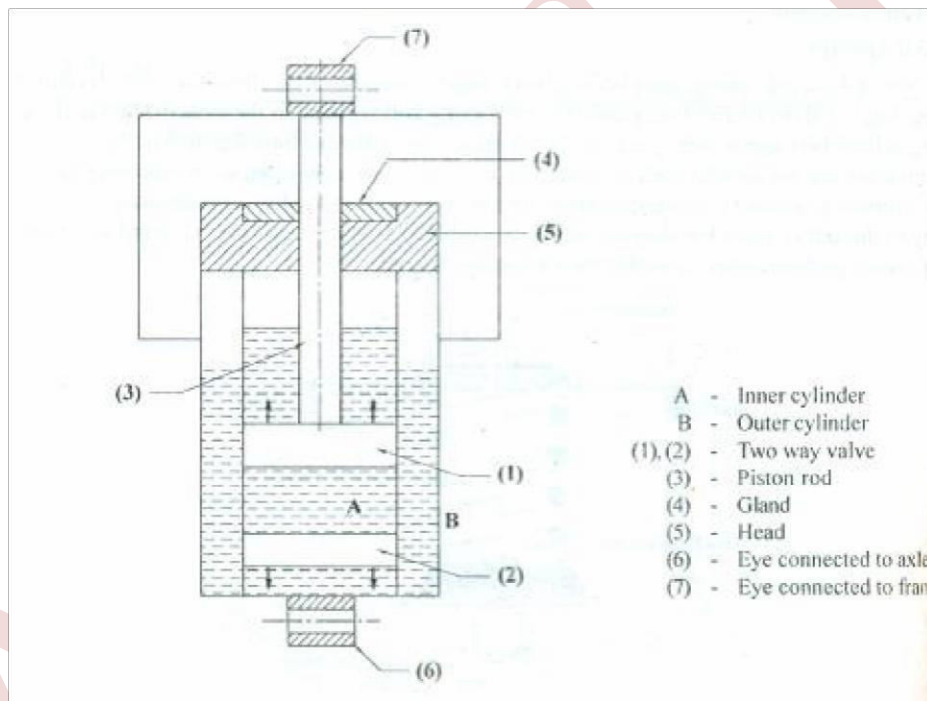
Shock absorbers are necessary as the springs do not 'settle down' fast enough. In other words, after a spring has been compressed and released, it continues to shorten and lengthens or oscillates for a time.

If a wheel of car hits a bump, the spring compresses. Then the spring expands after the wheel passes bump, the expansion of the spring causes the car to be thrown upward. Now, having over-expanded, the spring shortens again. This action causes the wheel to momentarily leave the road and the car drops down. The action is repeated until the oscillation gradually dies out.

Such spring action on a car would produce a very bumpy and uncomfortable ride. It could also be dangerous because a bouncing wheel would make the car impossible to control. This would be especially dangerous on a curve. It is obvious, therefore, that a device is needed to control the oscillating action of the spring. This device is known as the Shock absorber.

Out of so many types of shock absorbers available such as Vane type, opposed piston etc, telescopic shock absorber is most commonly used.

The telescopic shock absorber consists of an outer cylinder, inner cylinder, piston and piston rod and in some cases an outer dust and rock shield. At the bottom of the inner cylinder and in the piston a series of valves controls the movements of the hydraulic fluid within the shock absorber.



**Fig: Illustrates the working of telescopic shock absorber**

Fig illustrates the working of Telescopic shock absorber. In this, piston rod is attached to the two way valve '1', while valve '2' which is also a two way valve is attached between cylinder and tube as shown in fig. The inner and outer cylinders are filled with oil. When the vehicle comes across a bump, the eye connected to axle will move up. With this the oil below valve '1' will moves up. Due to the resistance to the flow of oil through valve '1' it exerts pressure on valve '2'. This allows oil to flow through valve '2' also.

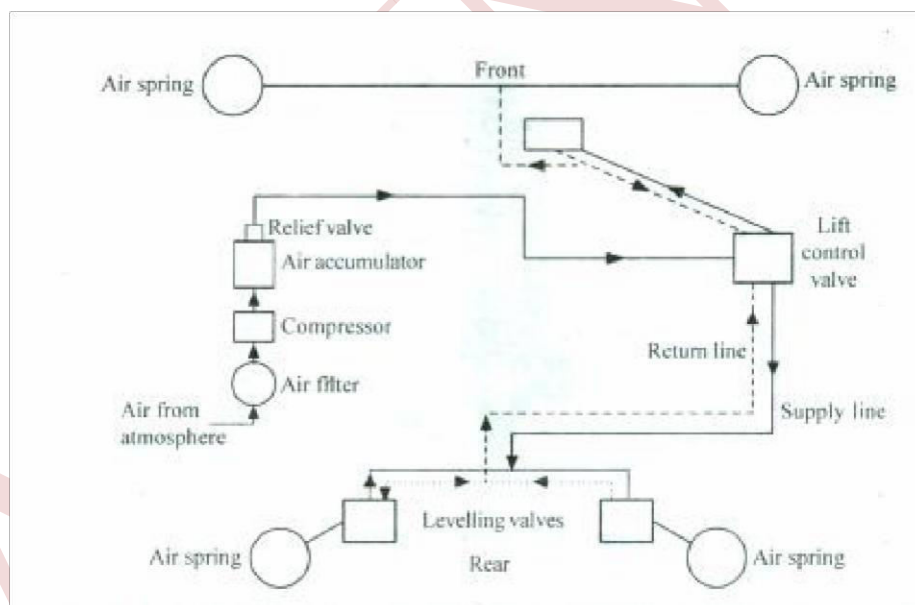
The flow of oil through valves 1 & 2 will be slow because of damping effect. In the similar way, for the down ward movement of the eye connected to axle, because of road irregularities, the oil will move from the upper side of valve '1' to the lower side and vice - versa.

## AIR SUSPENSION SYSTEM

Air or pneumatic suspension is incorporated in some tourist buses to improve the riding comfort of the passengers. The air suspension system possesses the following advantages over conventional metal springs.

1. The spring rate varies much less between laden and un-laden conditions, this decreases dynamic loading.
2. Changes in head lamp alignment due to change in load are avoided.
3. It improves riding comfort to the passengers.
4. Longer service life of the vehicle due to improved smoothness of run.

In air suspension system, four air springs (air bags) which may be of bellow type or piston type are used instead of coil springs. The atmospheric air passes through a filter and compressor raises its pressure to about 24kg / mm<sup>2</sup> and air at this pressure is accumulated in an accumulator. The relief valve in the accumulator tank acts as a safety valve. This high pressure air then enters to the air springs through lift control valve and leveling valves.



**Fig: Layout of air suspension system**

## BRAKES

Brakes are used as a stopping medium to stop or slow down the vehicle or to prevent the vehicle movement when it is parked (parking brakes). During braking the kinetic energy of the vehicle is dissipated as heat and is the reverse of accelerating a vehicle. When driving a vehicle engine torque produces a tractive effort at the driving wheels, and during braking, the braking torque at the brake drums produces a negative tractive effort or retarding force at the braking wheels. Similar to acceleration, the retarding force and rate of deceleration are also limited by adhesion available between tyre and the ground.

The brakes must be capable of decreasing vehicle speed faster than the engine accelerates it. While moving down a steep gradient, the brakes are used to control the vehicle and brakes remain in action for a longer period. This needs efficient cooling of the braking system.

### **BRAKING REQUIREMENTS**

The function of the brakes is to develop suitable retarding force to stop the vehicle within minimum possible distance and converts kinetic energy of the vehicle in to heat which is being dissipated to atmosphere.

To perform the above function, the brake system has to satisfy the following requirements.

1. Irrespective of vehicle speed, load conditions, type of road, the brakes must produce maximum possible retarding force and deceleration.
2. Irrespective of road condition and load, the pedal effort required should be same.
3. The response time of the braking system should be minimum possible.
4. The brakes must have good anti fade characteristics. The brake effectiveness should not decrease due to prolonged application (While descending hills). This needs efficient cooling of the brake system.
5. In an emergency, the brakes must be strong enough to stop the vehicle and in the mean time, driver must have proper control over the vehicle. The vehicle should not skid and should be consistent with safety.
6. The brake system should not be affected by water, dust, road grit etc.
7. The braking system should be as light as possible, easy to maintain and should give long, economical life.
8. The braking system should produce less noise and vibrations.
9. The system should facilitate the use of independent secondary brake and parking brake.

### **BRAKE EFFICIENCY AND STOPPING DISTANCE**

It is noted that to obtain maximum deceleration each wheel must have a brake and the ratio of retarding force to wheel load should be same for all wheels. The maximum deceleration (retarding force) attainable depends upon the tyre-road adhesion (coefficient of friction) and higher value of  $\mu$  gives shorter stopping distance. The maximum deceleration attainable is independent of the total (gross) vehicle weight, but requires greater braking force. We can write

$$F = f.l*W$$

Where, F = Maximum retarding force

f.l = Coefficient of friction

W = Component of vehicle weight on the wheel.

The total retarding force at the wheels is equal to the vehicle weight itself, when coefficient of friction is unity. In this case, the brakes are 100 percent efficient and the vehicle experiences a deceleration which is equal to acceleration due to gravity.

In ordinary vehicles, by considering passengers safety in passenger vehicles and safety of cabin in goods vehicles, 100 % efficient brakes are not used. If the brakes suddenly stop the vehicle



due to high deceleration, it might injure the passengers or would cause the load to slide and breaks the cabin. Highly efficient brakes also causes rapid wear of tyres, (thus reduces tyre life), and brake linings and it is difficult to control the vehicle during the application of brakes.

Thus, in general brakes with efficiencies of 50% to 80% are used to stop the vehicle within reasonable distance. For any vehicle, the minimum brake efficiency is said to be 50% for foot brakes and 30% for hand brakes.

The following table shows the approximate stopping distances at different speeds for various brake efficiencies.

**Table:** Shortest stopping distance.

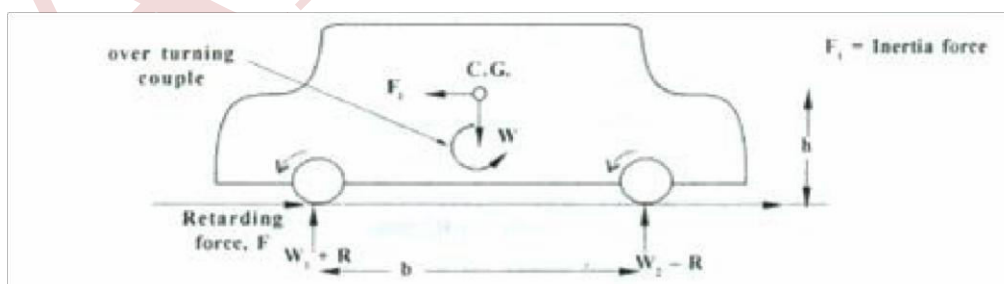
Efficiency %	Approximate stopping distance (m) for different speeds			
	30 km/h	50 km/h	80 km/h	100 km/h
100	3.5	9.5	25.5	40.0
80	4.5	12.0	31.5	49.0
60	6.0	16.0	42.0	65.5
30	12.0	32.5	85.0	131.0

The values given in the table vary depending on type of road surface, condition of tyre treads etc.

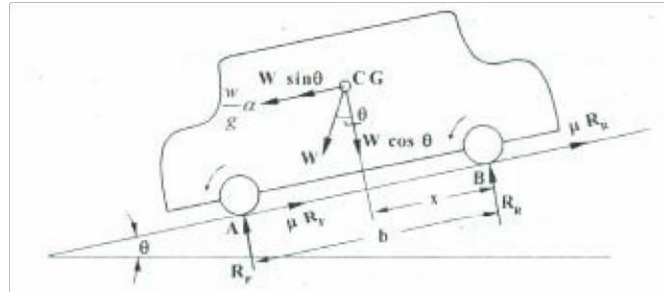
**WEIGHT TRANSFER PHENOMENA**

It is observed that, for maximum deceleration the amount of braking effort applied to each wheel should be proportional to the load carried by that wheel. Thus the total retarding force 'F' is the sum of retarding forces produced at front and rear wheels i.e.  $F = F_f + F_r$

In a vehicle, the front and rear wheels supports different loads and the static weight distribution depends on the design and type of vehicle. Also the static load on each axle changes depending on strength of passengers and other loads. It becomes difficult to decide braking effort distribution between front and rear wheels.



**Fig (a): Weight transfer**



**Fig (b): Forces on vehicle moving on an incline**

The figure (a) and (b) shows forces acting when brakes applied to a moving vehicle.

During retarding period, the inertia force acts through the centre of gravity of the vehicle, and the retarding force acts at the road surface. These two forces produces an over turning couple as shown in figure. This over turning couple reduces the load on the rear wheels and increases the same on front wheels. This effect is called 'weight transfer effect'. Some vehicle weight is thus transferred to the front axle. This can be further explained as follows;

When brakes are applied, a retarding force 'F' between the tyre and road causes the vehicle to decelerate. The inertia force  $F_1$  equal to magnitude of force 'F' acts through C.G of the vehicle the direction opposite to 'F'. These forces F and  $F_1$  constitute an overturning couple of magnitude equal to  $F \times h$ . This overturning couple causes the rear wheels to rise about front wheels as pivot int. Thus, some of the vehicle weight is transferred from rear to front wheels and balances the overturning couple. This causes a small decrease in 'R' at the rear wheels (reaction) and increasing same .at the front wheels. The forces '+R' and '-R' results in a righting couple to balance returning couple.

i.e.  $R \times b = F_1 \times h$ .

## TYPES OF BRAKES

The automobile brakes are classified by considering several factors.

### (i) Primary and Secondary Brakes

Primary brakes are the service or main brakes which are used to stop the vehicle within a minimum possible distance, when the vehicle is in motion.

Secondary brakes are the parking brakes which are used to hold the vehicle on a slope, when it is stationary.

### (ii) Transmission Brakes and Wheel Brakes

The location of brakes may be either at the transmission or at the wheels. In transmission brakes, heat dissipation rate is very poor and it consists of only one brake drum. In this type, the braking torque has to be transmitted through universal joints, propeller shaft, differential and back axle. This needs additional care while designing these components and also sizes have to be increased proportionately. The differential distributes the braking torque equally between two wheels. These brakes are stronger than wheel brakes.

In wheel brakes, each wheel may consist of one brake drum and this increases the area

available for heat dissipation and thus provides efficient cooling of brake drums. (Also the brake drums are exposed to atmosphere).

The automobiles are usually provided with wheel brakes.

### (iii) Drum Brakes and Disc Brakes

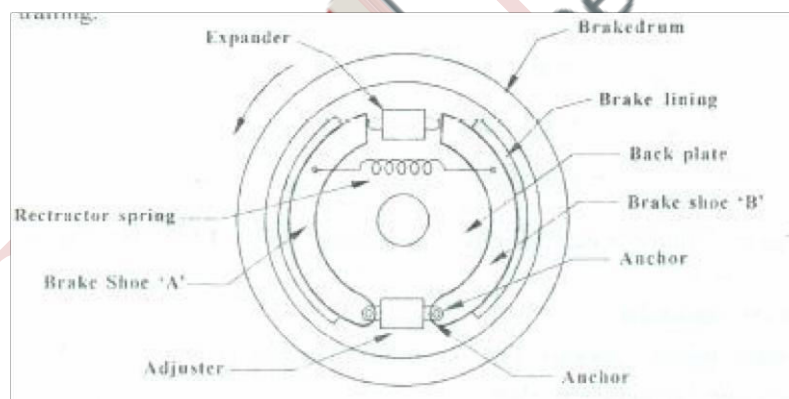
Depending on the construction, brakes are classified in to disc and drum brakes and these have been explained in detail at later portions of this chapter.

### (iv) Mechanical, Hydraulic, Electric, Vacuum and Air Brakes

Depending on the method of actuating the brake shoe, the brakes are classified into mechanical, Hydraulic, vacuum and air brakes.

### BRAKE SHOE ARRANGEMENTS

The drum brakes essentially consist of brake shoes and the arrangement of brake shoes is very important. The relative braking torque acting at the brake shoes for the same force applied by the pedal changes depending on whether expander which forces the brake shoe is fixed to the back plate or kept floating; whether anchor is fixed or floating and whether the brake shoes are leading or trailing.



**Fig: Components or a Drum Brake**

#### (i) Fixed Expander Type

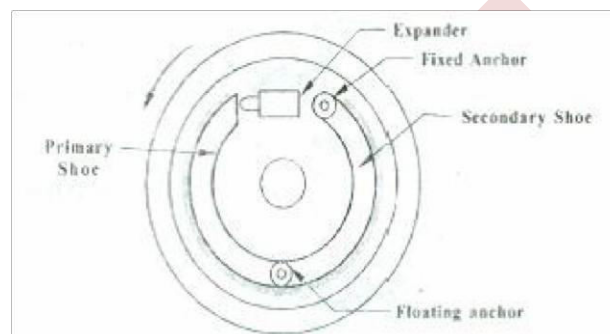
The expander unit provides the necessary force required to apply the brakes. If it is fed to the back plate, the brake shoe 'A' will become leading shoe and shoe 'B' will become trailing shoe. Leading shoe means, even when there is no braking force, the shoe will tend to drag along the brake drum. Trailing shoe means, it will tend to drag opposite to the direction of rotation of brake drum (refer fig.). Thus, when brakes are applied, the net force on the leading shoe becomes more than that of on the trailing shoe. This would result in unequal braking effect at the two shoes. The trailing shoe has better anti fade characteristic than leading shoe. At higher temperature due to increased braking effect, with prolonged application of brake, the friction coefficient decreases in case of leading shoe and it fades quicker.

**(ii) Floating Expander Type**

In this type, the expander unit is kept floating and automatically balances the braking effect at the two shoes and thus produces equal braking effect on two shoes. The floating expander also compensates lining wear by moving to one side so that both the shoes receive equal actuating force. However the lining wear on both the shoes is still unequal.

**(iii) Floating Anchor Type**

In this type, the two brake shoes are connected together at the anchor which is kept floating. These two shoes have a common anchor fixed to the back plate. The floating anchor makes both shoes leading.



**Fig: Brake in which anchor is kept floating**

**(iv) Two Leading Shoe Type**

When anchor is kept floating, both the shoes tend to act as leading type. It has a high degree of self energisation and this increases the braking torque. The lining wear is also uniform on both the shoes. These brakes are very sensitive [0 friction changes and thus will not be best suited for brakes meant for prolonged application. Also both the shoes act as trailing shoes when the vehicle moves reverse and this reduces the braking effect. These brakes have better fading characteristics.

**(v) Two Trailing Shoe Type**

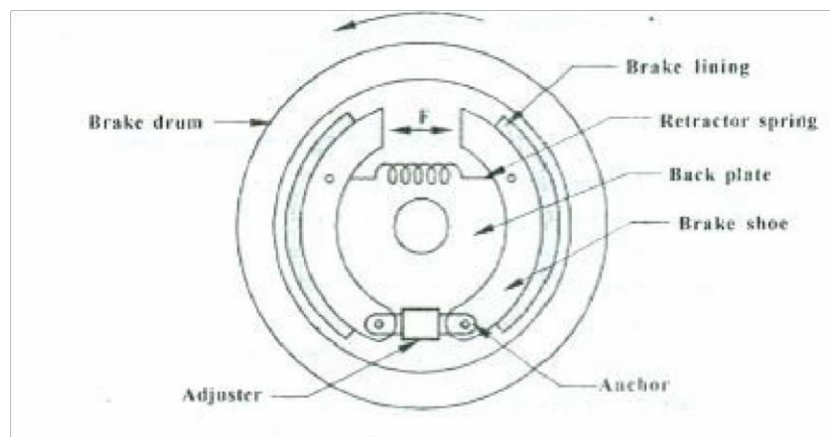
When both the shoes are trailing, braking effort at the wheels decreases. For this reason, trailing brakes are generally used with servo brakes or power brakes to reduce driver's fatigue. These brakes have better anti fade properties and thus provide more consistent braking.

**DRUM BRAKES**

These brakes are most commonly used and brake shoes are actuated by mechanical means (arm or toggle lever) and make contact with the inside of the brake drum. The rods and levers decrease the pedal effort required by the driver through mechanical advantage or lever.

This consists of a brake drum which is fixed to the hub of the road wheel and the back plate is mounted on the axle casing. On the front side, the back plate is fixed to the steering knuckle through bolts. The expander, anchor and brake shoes are all supported on the back plate which is made from pressed steel sheet. It protects the drum and shoe assembly from mud and dust. As it absorbs the complete torque reaction of the shoes, it is also called as "torque plate". Two brake shoes which are semi-circular in shape are anchored on the back plate. Friction linings are attached on the

outer periphery of the brake shoes, through which it makes contact with the drum. The brake shoe rubs against wheel rim through friction lining and locks the wheel. One or two retractor springs are used which keeps the brake shoes away from the drum, when brakes are not applied. The brake shoes are anchored at one end and on the other ends force is applied by using some brake actuating mechanism, may be an expander or wheel cylinder. The expander is operated by using a link rod which is connected to the brake pedal. The expander forces the brake shoe to rub against revolving wheel drum from inside, there by applying the brakes. An adjuster serves to adjust the wear of friction lining with use.



**Fig: Drum Brakes**

### FACTORS INFLUENCING BRAKING EFFECT

The factors which affect the ability of brakes are (refer fig.).

Radius of brake drum ( $R_1$ ) and radius of the wheel ( $R_2$ ), If 'F' is the retarding force at the ground, then,  $F = F_1 \cdot R_1$

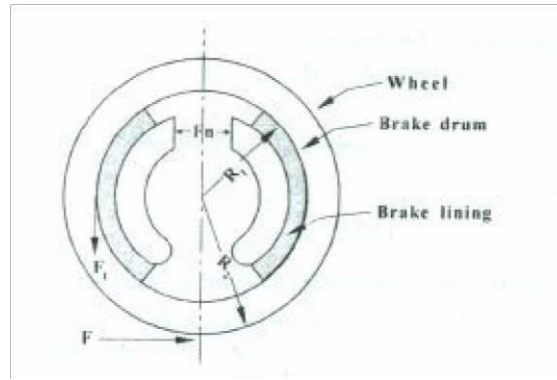
Where  $F_1$  = Retarding force on brake drum  $F_2$  = Retarding force on brake drum

$F_2 = \mu_B \times F_n$ , where

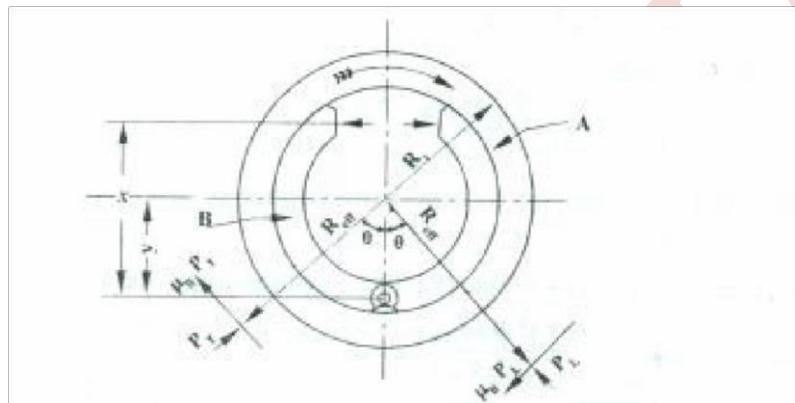
$\mu_B$  = Coefficient of friction between brake lining and drum.  $F_n$  = Normal force applied on brake shoes.

From the above discussion, it is clear that, the retarding force 'F' is dependent on dimensions or sizes of brake drum and wheel.

- The braking effect can be increased by area of brake lining and pressure applied at the brake lining.
- The braking effect also depends upon the coefficient of friction between braking surfaces and between tyre and road, but too higher friction coefficients may lock the wheels.



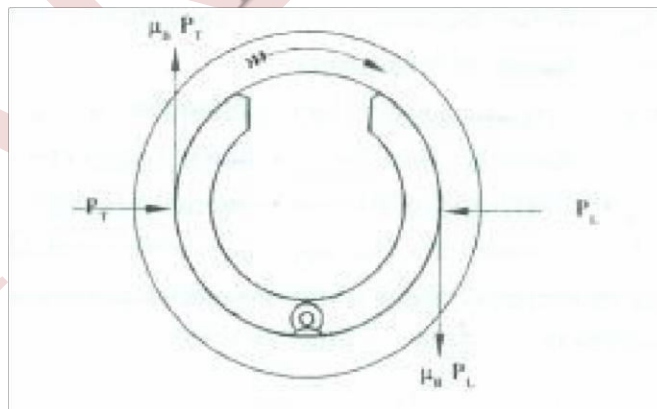
**Fig: Braking effect**



**Fig: Forces in internally expanding shoe brake**

Consider the brake drum and various forces acting on brake shoe as shown in figure For the given rotation of brake drum, shown in figure 8.6, brake shoe 'A' becomes leading one and 'B' will act as trailing shoe.

**CALCULATION OF HEAT GENERATION DURING BRAKING**



**Fig: Forces acting between shoes and drum**

Let  $P_L$  and  $P_T$  are the normal forces acting between shoe and the drum for leading and trailing shoes respectively. This produces friction forces on the shoes which act perpendicular to the forces  $P_L$  and  $P_T$ . To make the calculation simple, the following assumptions are made.

- (i) The brake consists of symmetrical linings.
- (ii) The normal and friction forces act at the lining contact centre point of leading or trailing shoe.
- (iii) The normal forces on leading and trailing shoes are equal.
- (iv) The value of  $\mu$  is independent of pressure and velocity.

**WKT**, Work done in braking = Braking force x distance moved =  $F \cdot S$  Nm

Amount of heat generated during this braking operation =  $F \cdot S$  Nm (J)

Heat generated at each wheel =  $F \cdot S$  J

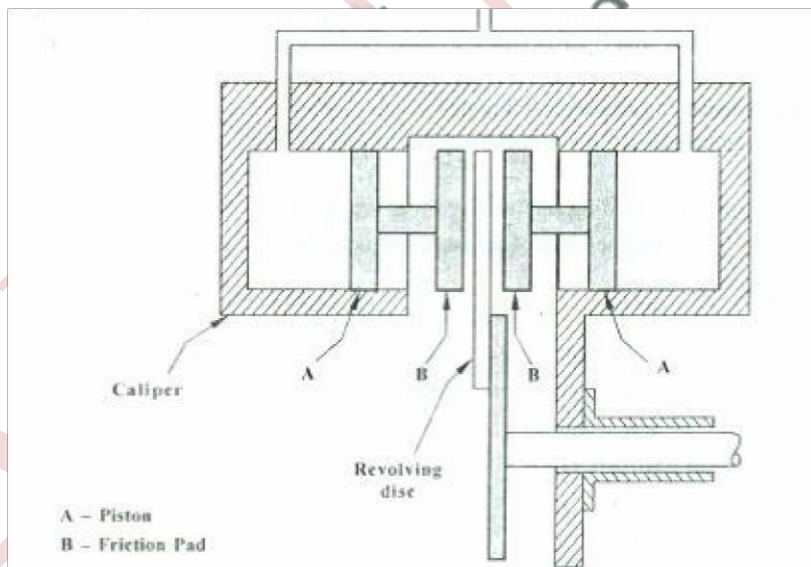
Heat generated per second at each wheel  $F \cdot S \cdot V = 4t = 4$  J/S or W

Where  $V$  = Speed in m/s.

**Table:** Types of brakes used in Indian automobile

SI. No.	Vehicle Make	Type of Brake
1.	Maruti (Suzuki) 800	Hydraulic Front - Disc Type Rear - Drum Type
2.	Hindustan Ambassador	Hydraulic
3.	Fiat 1000 (Premier Padmini)	Hydraulic
4.	Jeep CJ Series	Hydraulic
5.	Ashok Layland Comet Passenger, Viking	Air Pressure Diaphragm - operated
6.	Tata 1210 E	Hydraulic, assisted by single chamber air pressure booster
7.	Standard 20	Hydraulic
8.	Swaraj Mazda	Hydraulic with vacuum booster

**DISC BRAKES**



**Fig: Disc brake (fixed caliper type)**

The disc brake differs from drum brakes in the use of heavy disc or rotor (a circular plate) which replaces the drum. The disc is bolted to the wheel hub and revolves with it. The caliper is a stationary housing connected to axle casing or stub axle and consists of two hydraulic pistons, to the end of which brake friction pad are attached, one on each side of the disc. Passages are drilled in the caliper for the fluid to enter and leave each housing. Disc brake has excellent cooling characteristics, making it highly resistant to brake “fade”. When the brakes are applied, hydraulic pressure is built up behind the pistons and the friction pads are forced inward against the revolving disc, providing braking effort. This force of the friction pad on both side, will retard the disc. On releasing the brakes, the rubber sealing rings (not shown in figure) acts as return springs and causes the pistons



and hence friction pads to move away from the disc, there by releasing it.

This requires higher operating force than drum type. More than one caliper may be used, but this reduces the cooling rate.

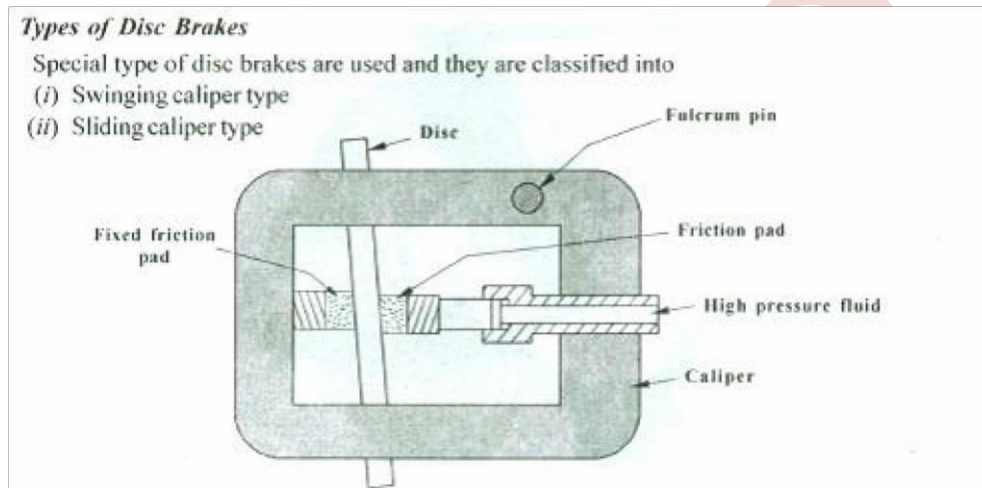
The torque output of the disc brake is given by  $T = 11. W. R n$ ,

Where, W - Force applied to each of friction pads.

n - Number of friction pads.

R- Mean radius of friction pad ( $r_1+r_2$ )

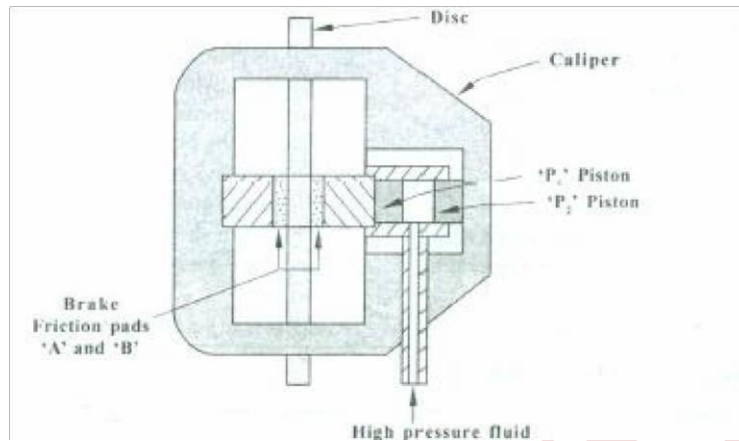
This torque output is not affected by the direction of disc rotation.



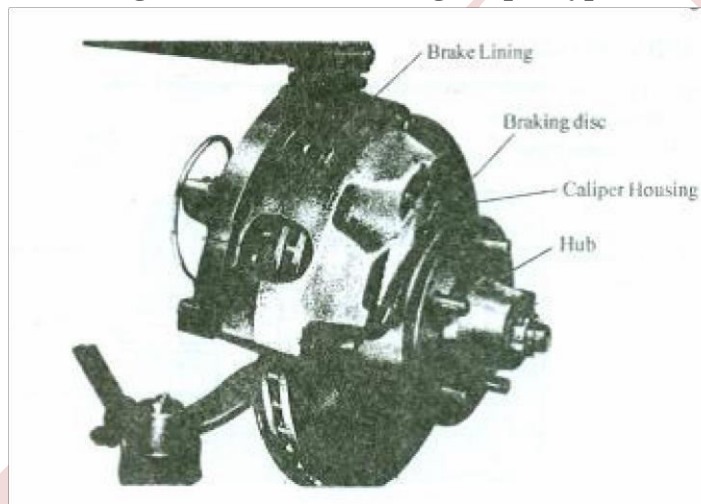
**Fig: Disc brake of swinging caliper type**

A swinging caliper type disc brake uses a single piston on one side only. One friction pad is fixed to the caliper which is hinged about a fulcrum point as shown in fig. When brakes are applied, the high pressure fluid presses the other friction pad against the revolving disc and caliper exerts reaction from opposite side and causes the fixed friction pad to move slightly inward. The caliper automatically changes its position by swinging about the fulcrum pin and thus exerts pressure- on the other side of the disc, thus provides braking effort.

A sliding caliper type as shown in fig, uses two pistons "P1 and P2" and the high pressure fluid directly exerts pressure on one friction pad "B" through the piston "P 1". The piston P2 causes the caliper to move slightly to right, there by moving the friction pad' A', attached to it. Thus the friction pad' A' exerts pressure on the disc, through the sliding motion of the caliper, and required braking effort can be obtained.



**Fig: Disc brake of sliding caliper type**



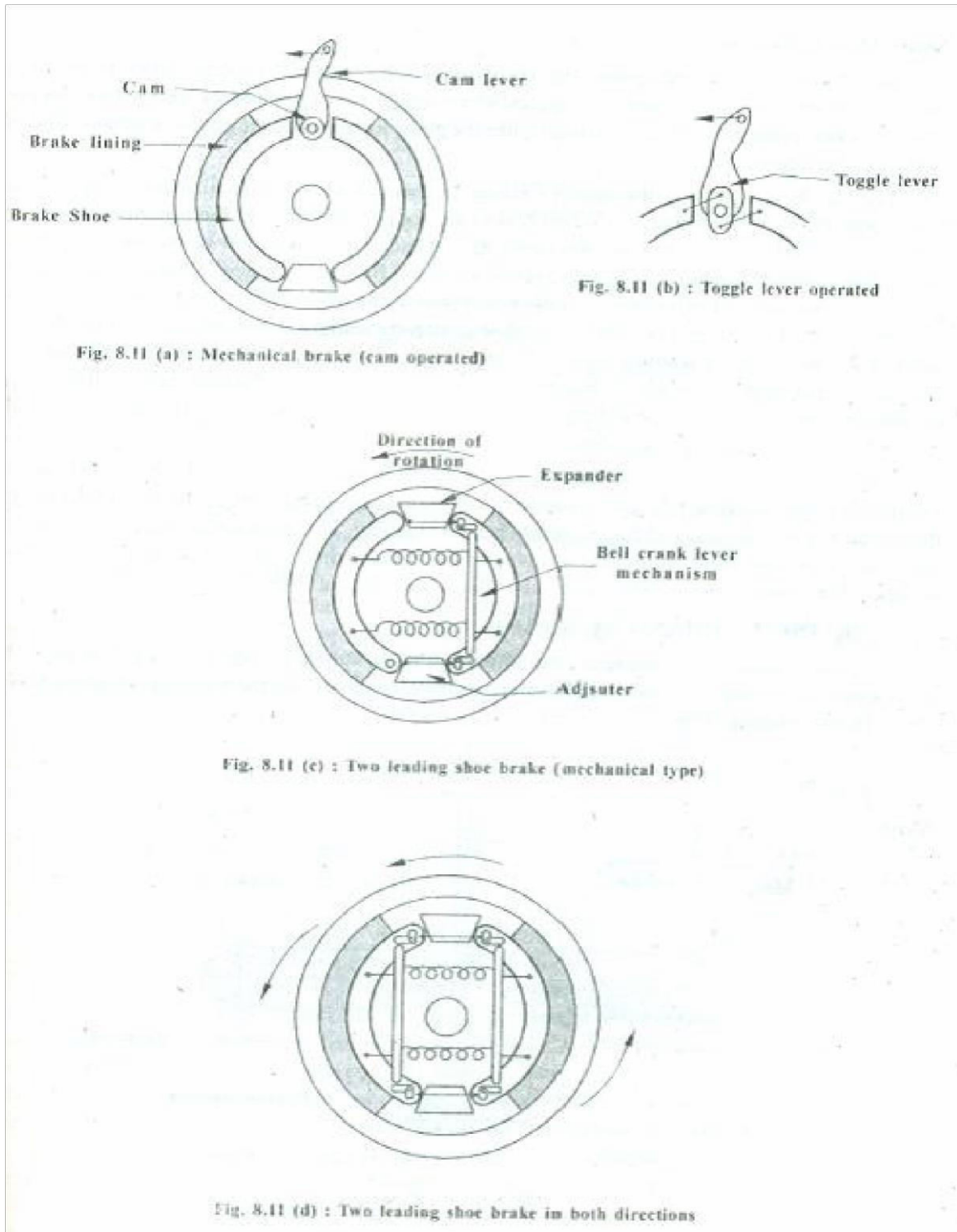
**Fig: Typical front wheel disc brake.**

**Comparison of Disc and Drum Types of Brakes**

Sl.No	<i>Disc Brakes</i>	<i>Drum Brakes</i>
1	More efficient cooling	Less efficient cooling
2	As flat friction pads are used, wear is more uniform.	Semi-circular friction linings on the brake results in non uniform wear.
3	The weight is less, resulting in lower inertia.	Comparatively, the weight of the drum is more
4	These are more stable.	Comparatively less stable.
5	Maintenance and service of the drum is to be brakes is easy.	For service and other works, the drum should be removed which takes more time.
6	These have better anti-fade characteristics.	The braking effect decreases with prolonged application of brakes.
7	These do not have self-servo action and decreases the braking force required.	The brake shoes experience self-servo action and hence require greater operating force.
8	Total frictional area available is less.	Total frictional area available is more.

**MECHANICAL BRAKES**

All modern cars have been using hydraulic brakes as service brakes since 1940, but mechanical brakes are still used in parking and emergency brakes. In the mechanical brakes, the pressure from the brake pedal is transmitted to the wheel brakes through rods and shafts or cables and shafts.



### Brake Shoe Operation

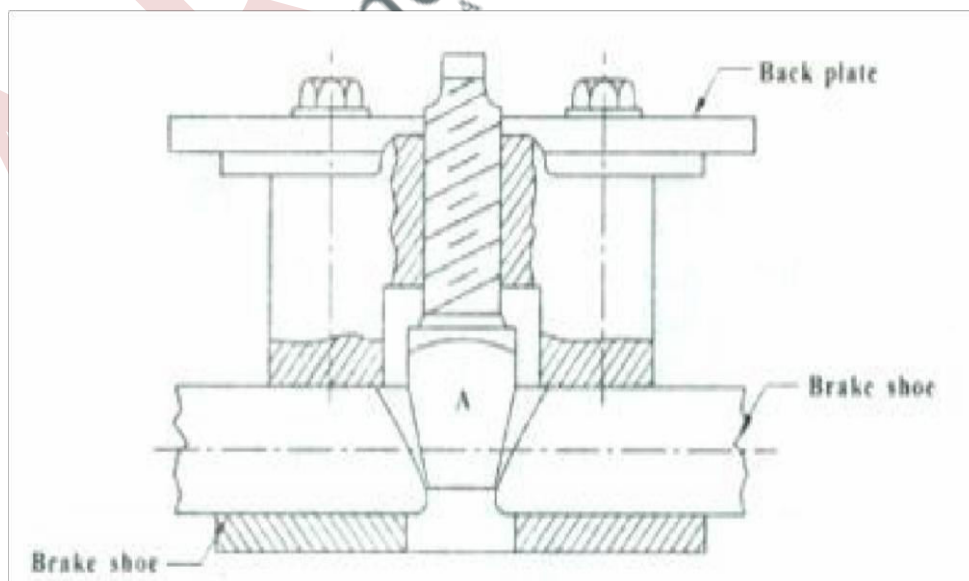
The shoes are operated against the revolving drum by cams or toggle lever as shown in fig. (a) and (b). These cams or toggles levers are in turn operated by various mechanical linkages. The mechanical linkage also multiplies the pedal force through leverage to obtain effective braking effort against the drum.

The fig. (c) Shows the use of Girling mechanism in mechanical brake system which makes both the shoes leading type. When brakes are applied, the force at the expander pushes the arm of upper bell crank lever, this transmits its motion to the lower part of the mechanism and causes lower arm of the bell crank to move towards left. But the presence of adjuster mechanism gives a reaction and makes the whole of the brake shoe at the lower end to move toward right, thus making it to act as leading type. The other shoe is already leading. Hence the Girling mechanism makes both the shoes of leading type. The drawback of the system is, when the automobile is moving reverse, both the shoes will become trailing and the braking effect available at the shoes is considerably reduced. This is not the point to be considered, as on reverse, vehicle moves slowly and braking effort required is also less.

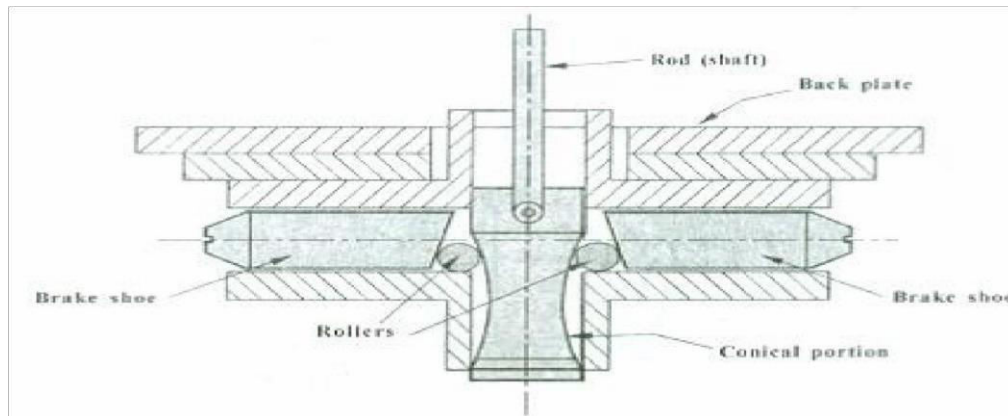
Fig. (d) Shows one method of making both the shoes leading in both the direction of rotation of the drum. When the vehicle is moving in reverse direction, the brake shoes bear against the expanding mechanism and consequently become leading. This overcomes the disadvantage of one - struct arrangement in reverse. Anyhow two leading shoe system are used only on front brakes, where more braking effort is required due to weight transfer.

### GIRLING MECHANICAL BRAKE

It mainly consists of expander and adjuster unit as known in fig. (c). the expander provides the actuating force required to operate the brake shoes and the adjuster compensates for wear of friction lining.



**Fig: Expander**



**Fig: Adjuster**

The expander consists of a shaft, the end portion of which is made conical shape as in fig. (a). The rollers are used between arc portion of the shaft and brake shoes to reduce the friction. When the shaft is pulled, conical portion moves up, moves the shoes apart through rollers. Thus the brake shoes tend to drag on the inner surface of the brake drum, thereby applying the brakes.

The adjuster is used to compensate the lining wear on the brake shoes. By screwing the conical portion 'A', brake shoes move apart, thus taking the wear of lining.

### HYDRAULIC BRAKES

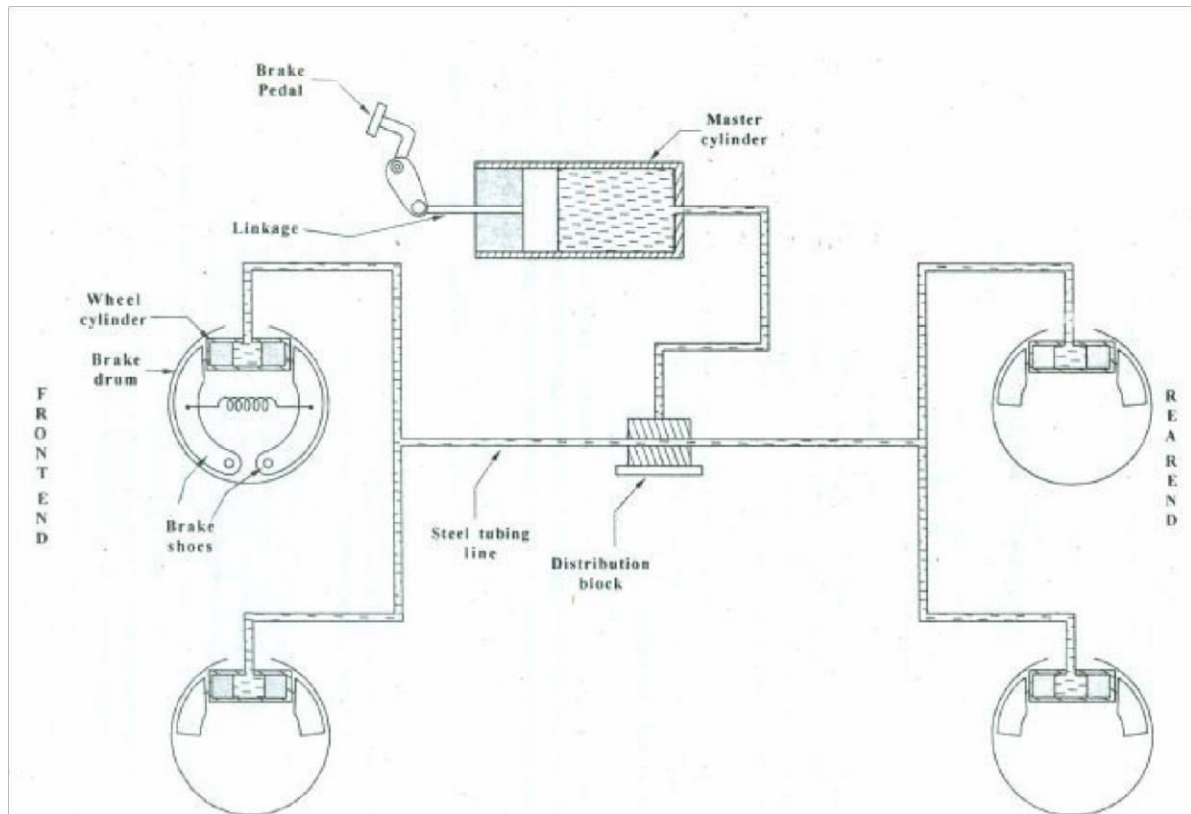
Basically, the car hydraulic braking system consists of a master cylinder, steel tubing to form connecting lines and one or two wheel cylinders for each wheel. In this type, the pedal force is transmitted to the brake shoes through brake fluid. The force applied to the pedal is multiplied and is transmitted to all the brake shoes. The brake fluid is incompressible and it exerts equal pressure in all directions. The brake pedal force is equally applied on all the wheel cylinders and produces equal braking effect on all the wheels. This force transmission is based on Pascal's law which states that "when pressure is exerted on a confined liquid, it transmits pressure without loss, equally in all directions".

When the driver operates the brake pedal, it exerts a force on the piston of master cylinder which is being transmitted to each wheel cylinder. The piston in the wheel cylinder transfers this force [increased or decreased, depending on piston area, (mechanical advantage)] to the brake shoes.

The movement of piston in master cylinder causes the pistons in wheel cylinders to move until the brake shoes engage the revolving brake drum. If an attempt is made to depress the master cylinder piston beyond this point will transmit only pressure, but not motion.

The fig. shows schematically the hydraulic system of a car having drum brakes on all four wheels. On the front wheels disk brakes may be used, instead of drum brakes. In Hindustan Ambassador car, on front wheels, a separate wheel cylinder is used to operate each brake shoe (both shoes leading) and on the rear wheels only one wheel cylinder is used to operate both the shoes (one leading - other trailing). Here all the shoes are of floating anchor type.

A small pressure of about 50 kpa is maintained in the steel piping to keep the wheel cylinder pistons in the expanded position, when brakes are not applied. This avoids entry of air into wheel cylinders when the brakes are released.



**Fig: Hydraulic Brake system**

### Master Cylinder

Master cylinder is the heart of the hydraulic braking system in which hydraulic pressure is developed. Its working is similar to a pump and converts the mechanical force on the brake pedal into hydraulic pressure. It is rigidly fastened to the car frame and linked by means of a pedal rod to the service brake foot pedal. Pressure of the driver's foot on the brake pedal is transmitted through various linkage arrangements, to a piston in the master cylinder. The forward motion of the piston in the cylinder pushes the brake fluid. Since the brake lines and wheel cylinders are filled with brake fluid, the piston acts on a solid column of fluid, thus forcing the wheel cylinder pistons. When the wheel cylinder pistons have pressed the brake shoes against the drums, fluid movement ceases and pressure increases depending on force on the piston of master cylinder.

### Construction

The fig. illustrates the construction of master cylinder. Essentially it consists of a supply tank or a reservoir and compression chamber in which the piston operates. The reservoir will supply additional fluid, when needed, to compensate for loss of fluid in the pipe lines due to temperature variations and due to minute leakage. The air vent provided in the cap will keep the brake fluid always at atmospheric pressure and allows expansion and contraction of the fluid without forming pressure or vacuum.

The compression chamber consists of an aluminum piston which is covered with rubber seals on both the ends to prevent leakage of brake fluid. The inner face of the piston presses against a rubber primary seal and this prevents leakage past the piston. The outer piston end has a rubber

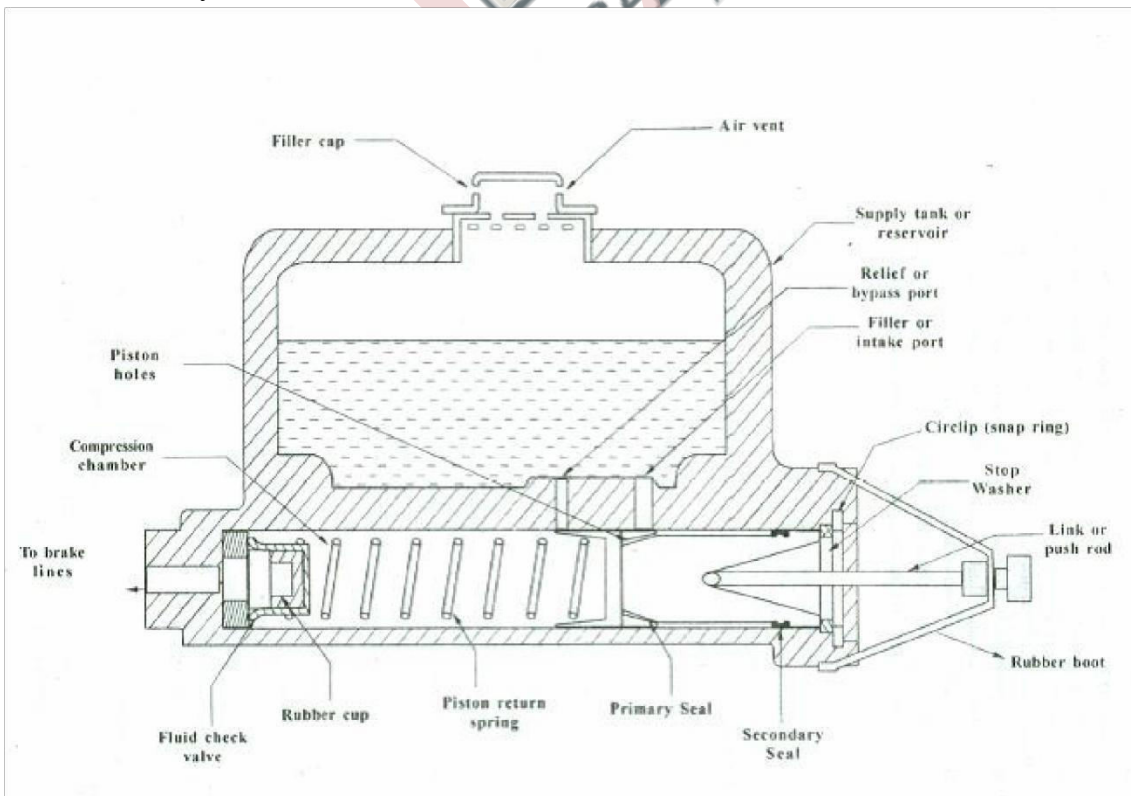
secondary seal to prevent fluid from leaving the master cylinder. The inner piston head has several small bleeder ports (piston holes) that pass through head to the base of the rubber primary seal. The piston is prevented from coming out by using stop washer and circlip as shown in figure. A push rod is used to apply the pressure and it connects the piston to the brake pedal linkage. A fluid check valve with a rubber cup inside is held against a rubber seat by a coil spring. The spring presses against the check valve, while the other end is against the piston primary seal. This serves to retain the residual pressure in the brake lines, even when the brakes are released.

On the primary seal side, a number of holes are located in the piston head. The bypass port (compensation or relief port) and intake (recuperation or filler port) port are used to connect the fluid reservoir to the compression chamber.

**Working**

When the brake pedal is pressed, push rod moves the piston inward (left) against the spring force, till it covers the bypass port. With bypass port closed, the further movement of the piston builds up the pressure in the compression chamber. This pressure forces the check valve inner rubber cup to open and pass fluid in to the lines. This fluid enters the wheel cylinder and causes the pistons in it to move out ward and force the shoes tightly against the rotating drum, thereby applying the brakes.

When the brake pedal is released, pressure from the brake shoe return springs forces fluid back against the check valve and the master cylinder piston moves outward (right) due to spring action in the master cylinder. The fluid under pressure will lift the check valve off its seat, allowing fluid to return to the cylinder.



**Fig: Master Cylinder**

The spring force in the master cylinder keeps the fluid check valve pressed on its seat for some time and hence delays the return of fluid from lines to the compression chamber. Some delay is also caused by fluid inertia in the lines. This creates a vacuum in the compression chamber and would result in air leakage in to the system and makes the brake useless. This problem is avoided by having an intake port as shown. As vacuum is created, the fluid reservoir in which the fluid is at atmospheric pressure, forces the fluid through intake port and holes in the piston which deflects the rubber cup and enters the compression chamber, thereby destroying the vacuum. In this way a complete column of liquid is always maintained between master cylinder piston and wheel cylinder pistons, ready for the next brake application.

But, by the time fluid from reservoir fills the vacuum; the fluid from the lines comes back and lifts the check valve of its seat. But compression chamber is already full and this extra fluid has to be accommodated somehow. Otherwise, this would cause the brakes to jam, as pressure in the lines has not been relieved fully. This problem is solved by means of a bypass port. The extra fluid from the lines passes through the bypass port to the reservoir, where atmospheric pressure is maintained.

### Wheel cylinder

In the brake system, wheel cylinder is used to transmit the pressure of the fluid in master cylinder to the brake shoes and force them against the revolving drum. One wheel cylinder (in some system, two) is used to each wheel to operate the brake shoes.

The figure shows the construction of wheel cylinder and the figure shows the simplified view of the wheel cylinder which is forcing the brake shoes outward against the drum. It consists of cast iron housing, two aluminum pistons (in some cases sintered iron pistons are used), rubber seals (cups), cup spreaders, coil spring and rubber boot (dust cover). The brake line from the master cylinder is connected to the inlet port. The cylinder is drilled to provide a bleeder screw, to bleed the air from the system, whenever required. The wheel cylinder is usually bolted to the brake backing plate.

When brakes are applied, master cylinder forces fluid in to wheel cylinder through inlet port and forces the pistons to move apart. This outward movement of the pistons pushes the brake shoes against the drum.

When the brakes are released, the piston move inward due to spring force and forces the brake fluid out of wheel cylinder.

## ADVANTAGES AND DISADVANTAGES OF HYDRAULIC BRAKING SYSTEM

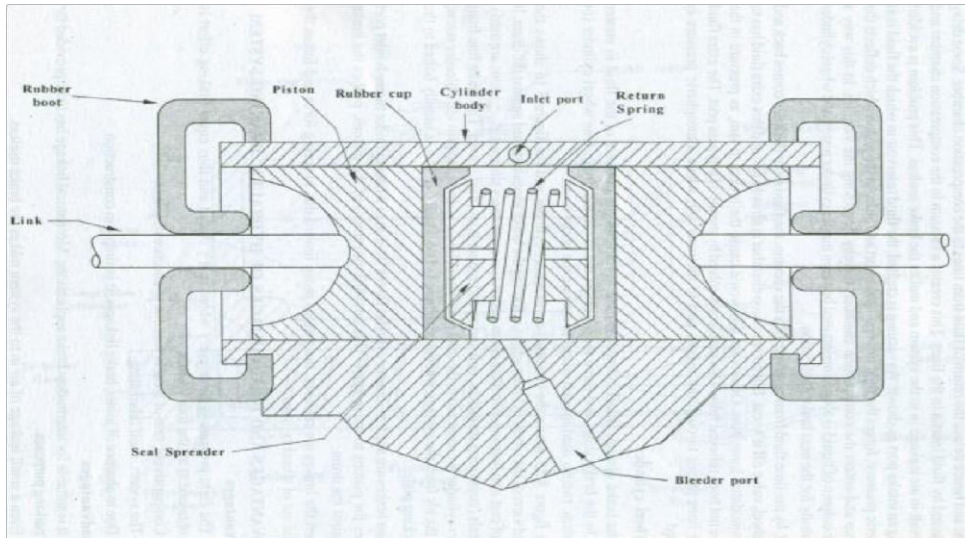
### Advantages

1. The fluid pressure is same everywhere in its circuit and thus equal braking effort is obtained at all the four wheels.
2. Comparatively, rate of wear is less due to absence of joints.
3. The system is self lubricating.
4. Due to absence of joints, brake linkages, it is simple in construction.

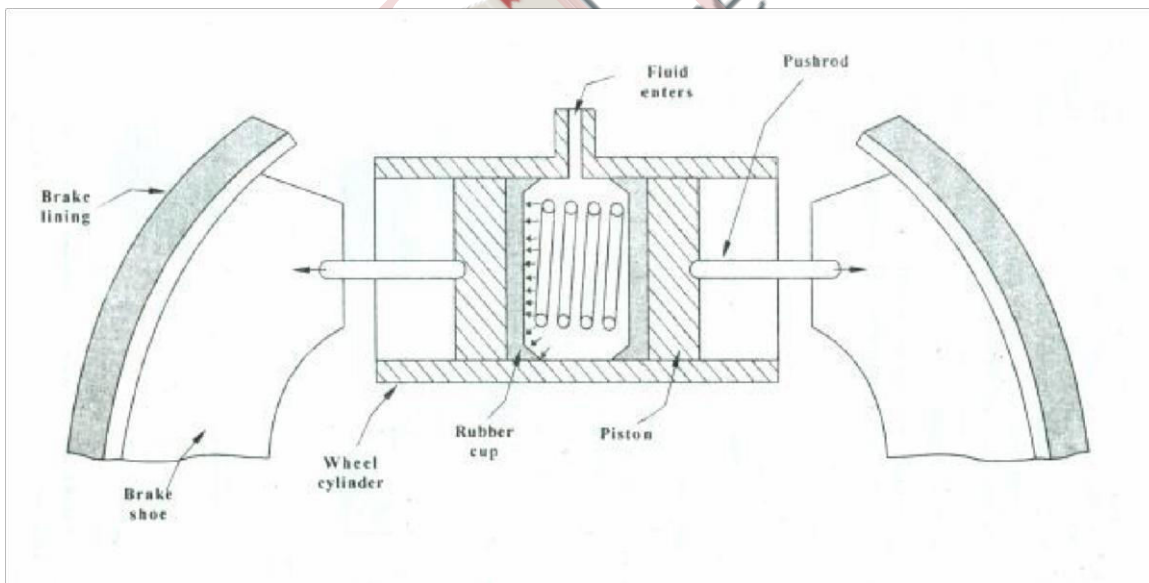


**Disadvantages**

1. It is suitable for intermittent brake applications. Mechanical linkage has to be provided for parking purposes.
2. Even a small leakage of air in to the system makes the brake useless.



**Fig: Wheel Cylinder**



**Fig: Simplified wheel cylinder action, arrow marks shows fluid pressing on rubber cup**

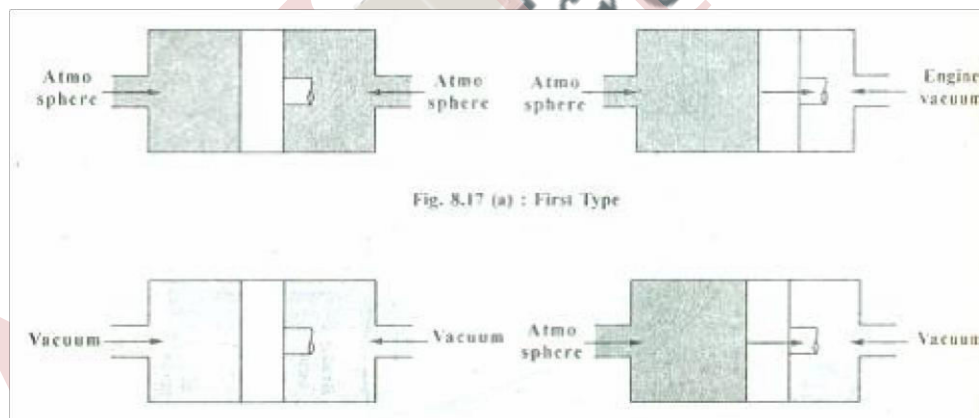
**POWER BRAKES**

When the vehicle weight is more, driver cannot apply the brakes comfortably without fatigue, some external source of energy is used-to supplement his effort which makes the brake application easier. For this reason, many of the vehicles are equipped with power brakes. The power brakes are used to reduce the amount of pedal pressure necessary to stop the vehicle. If energy for these brakes are taken from the transmission of the vehicle itself, which partly helps the driver i.e., driver still has

to put some effort while applying the brakes, then such brakes are 'called "Servo brakes or Power assisted brakes". Practically when none of the braking effort is applied by the driver, then the brakes 'are termed as "Power brakes or Power operated brakes".

The mechanism which supplements the driver's effort in applying the brakes is called a "servo mechanism". This servo action or self energization of brakes helps the driver to apply the brakes without fatigue.

Mechanical servos were used initially, but these have become obsolete after the introduction of vacuum operated servos. In vacuum servo brakes, the brakes are applied by utilizing engine suction from inlet manifold, A small vacuum reservoir may be provided to have enough vacuum for several brake applications even after engine has stopped. Vacuum servo brakes are of two types, both types consists of a piston or a diaphragm operating in a cylinder and are incorporated with suitable linkage for brake application. In the first type, on both the sides, piston is exposed to atmosphere, when the brakes are not applied. When the brakes are applied, engine vacuum will act on one side of piston and the differential pressure on both sides of the piston causes the linkage to operate the brakes. In the second type, both sides of the piston are subjected to vacuum when the brakes are in the released position. When brakes are applied, one side of piston is exposed to atmospheric pressure and the differential pressure on both sides of the piston, causes the linkage to operate. This system is more rapid in operation and hence preferred over the first type. The second type is called "Suspended Vacuum" system.



**Fig: Second type; suspended vacuum type Brakes in released position & when brakes are applied.**

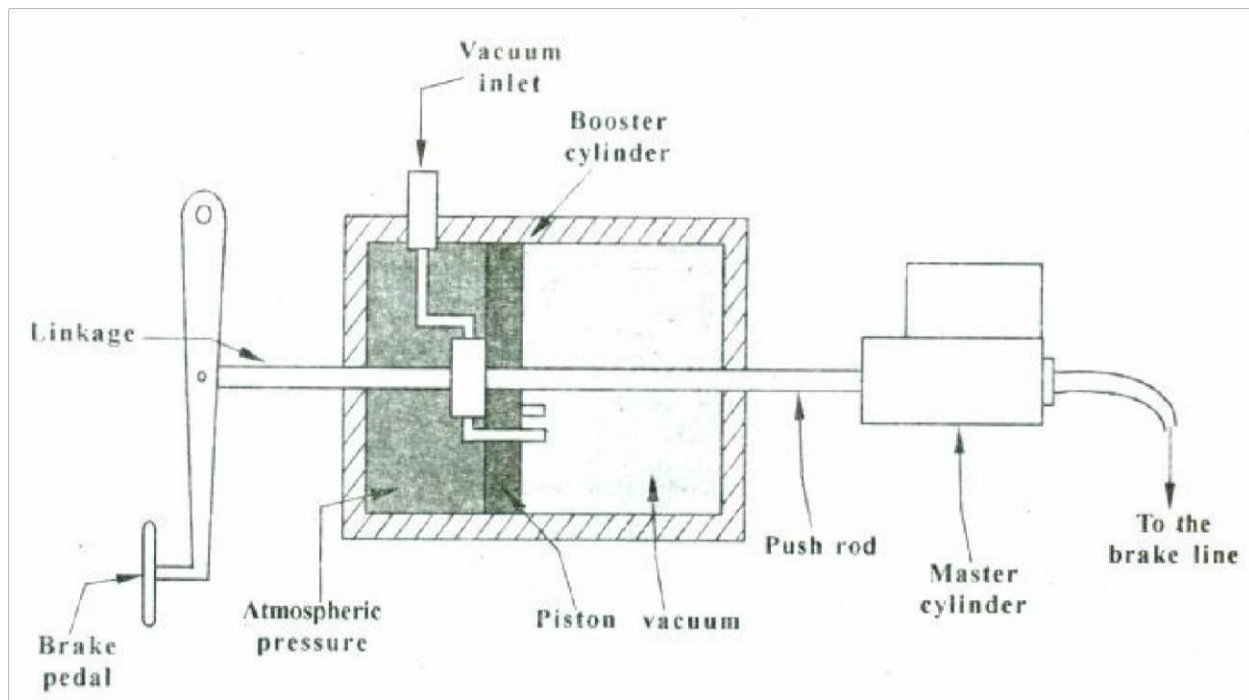
The figure shows one type of servo vacuum or power brake. It consists of a piston and cylinder arrangement as in figure. Master cylinder piston is connected to the one side of the piston and the other side of it is connected to the brake pedal. A vacuum control valve is placed between the brake and the piston. This valve admits vacuum to one side of the piston, while the other side is kept at atmospheric pressure. This valve can also allow atmospheric pressure to reach both sides of the piston.

When brakes are applied, the control valve closes off the atmospheric pressure to the master cylinder side of the piston (i.e. on the right side of the piston). Further movement of the brake pedal opens a vacuum inlet passage to this same side, and thus vacuum acts on this side of the piston. So, on the left side atmospheric pressure is acting and a partial vacuum is acting on the right side of the

piston. This differential pressure forces the piston to move to the vacuum side. 'As the master cylinder piston is connected to this piston (say P), it moves toward right and thus apply pressure to the brake system.

The power brakes have three stages of operation.

1. Brakes released
2. Applying brakes
3. Holding constant apply pressure.

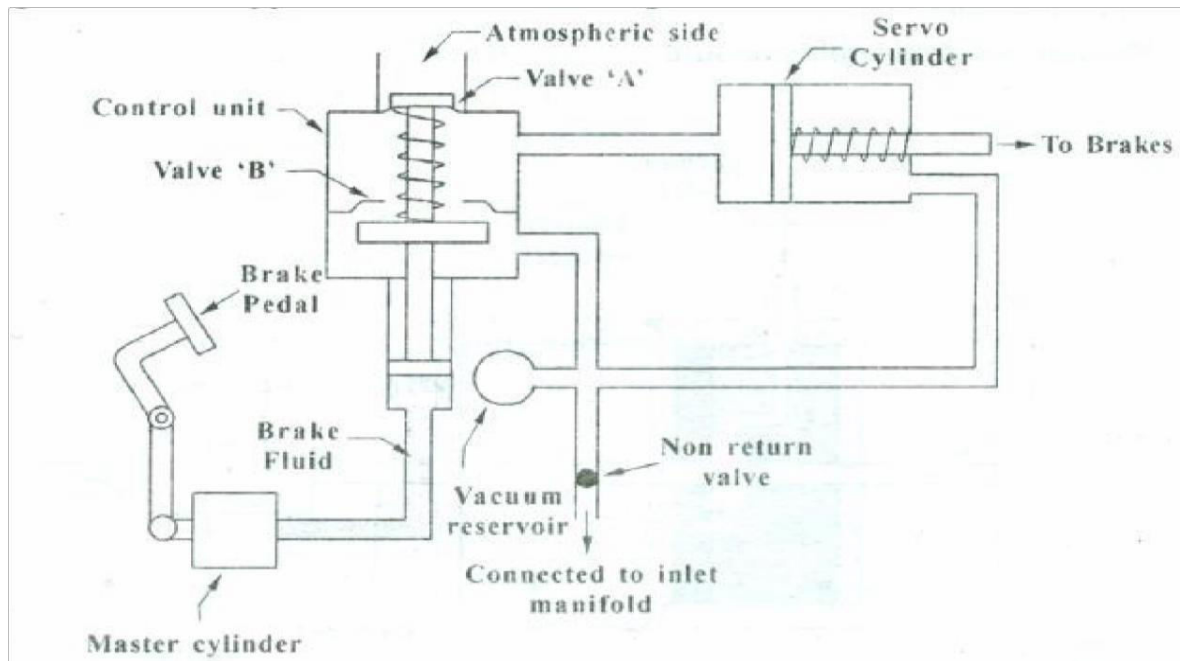


**Fig: Simplified Power brake system**

Another type of vacuum servo brake is as shown in figure .It consists of a vacuum reservoir which is connected to the inlet manifold between carburetor and engine. It also consists of a servo cylinder, one side of which is connected to vacuum reservoir through control unit, while the other side, it is direct connection. The control unit is provided with a piston and two valves 'A' and 'B'. Through upper valve (A) atmospheric pressure acts on the left side of the piston in servo cylinder, when valve 'A' is open. When lower valve (B) opens and 'A' closes, vacuum acts on the left side of the piston in the servo cylinder. On the right side of the piston in the servo cylinder, always vacuum will be acting. Through master cylinder, the brake pedal operates the piston in the control unit.

When the brake is in released position, valve 'A' is closed and valve 'B' is open. Thus engine vacuum is acting on both sides of the piston in servo cylinder.

When brake is applied, the pressure of the brake fluid pushes the control unit piston up and hence closes valve 'B' and opens valve 'A'. This opens left side of the piston in servo cylinder to atmospheric pressure, while on the right side vacuum is already acting. The differential pressure causes "the piston to move towards right and is used to apply the brakes through suitable linkages, which may be mechanical or hydraulic. This system reduces the driver's fatigue considerably and practically engine vacuum supplies whole of the braking effort.



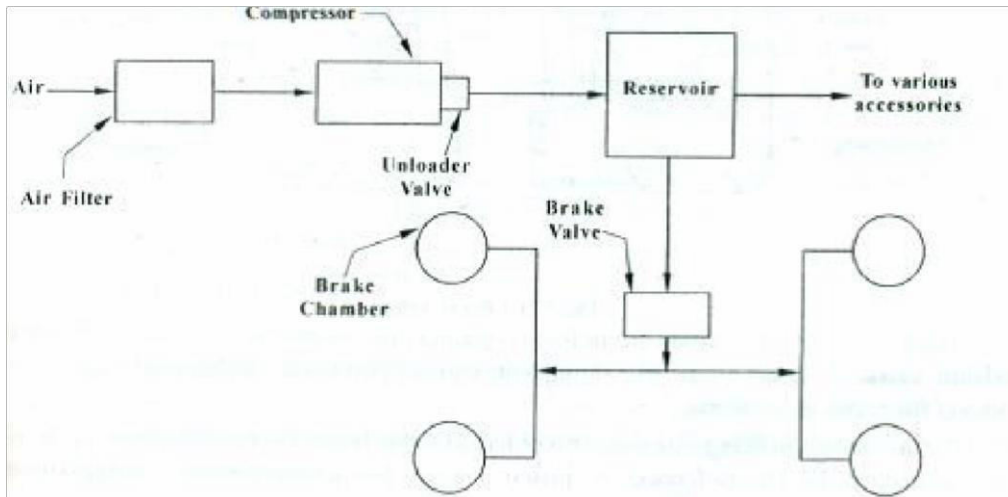
**Fig: Vacuum Servo Brake**

## AIR BRAKES

As vehicle weight increases (like heavy buses and trucks), heavier braking effort is required to stop the vehicle. Compressed air powered brakes are suitable for these heavy vehicles. These brakes consist of flexible diaphragms in brake chambers and are connected to the brake rods and controlled by hand or foot operated valve. The compressed air pressure acts on flexible diaphragm. The brake rods connect to brake operating cams on the wheel brakes. The braking operation is controlled by a brake valve which directs the air flow from reservoir against the diaphragms in the brake chambers during brake application and from brake chambers to the atmosphere, when brake is released. When the pressure in the reservoir falls below certain value, air compressor which is driven by engine, supplies the compressed air.

The layout of an air brake system is as shown in figure. The filtered air from the compressor passes to the reservoir through the unloaded valve which sends the air at a predetermined reservoir pressure (about 900 kpa). The reservoir supplies air to various accessories and diaphragm units (brake chambers) at each wheel through the brake valve.

In the air brake system, dust and other matter present in air is removed by passing it through an air filter. An air compressor driven by the engine, raise the pressure of air to the required level and supplies high pressure air to brake chambers at wheels through un loader valve. This valve mainly consists of a governor valve, plunger and non-return valve and regulates the brake line pressure in the system. A reservoir or air tank made from steel sheet stores the compressed air at the specified pressure and is used for brake application. The reservoir is also provided with a safety valve to control the air pressure in it. The brake valve (application valve) is used to regulate the braking intensity in an air pressure system. Tile brake valve supplies air to the various brake chambers at the required pressure. One brake chamber is installed on each wheel. In the brake chambers the pressure energy of compressed air is converted in to useful mechanical work (piston movements) and is used for brake application.

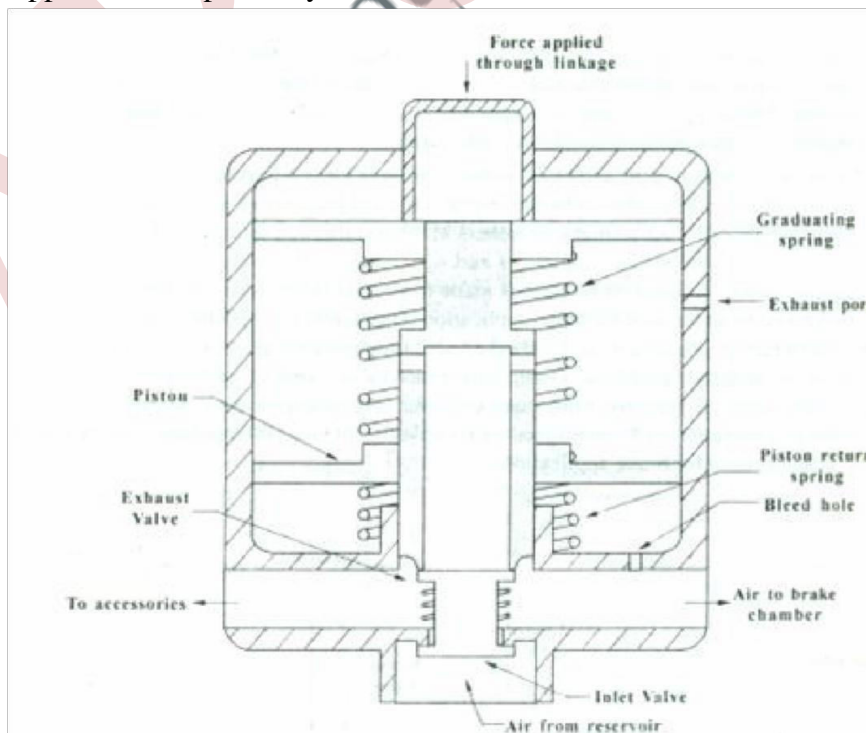


**Fig: Layout of air brake system**

**Brake Valve**

The brake valve consists of a spring loaded hollow piston inlet and exhaust valves, air bleed hole and exhaust port. The compressed air from the reservoir is admitted to the brake valve through inlet valve and on one side it goes to various accessories like stop light switch etc. and on the other side, it goes to the brake chamber at each wheel.

When brake is applied, the force is transmitted through the linkage to the brake valve, so that piston is moved down against the force of graduating spring. This piston movement closes the exhaust valve and opens the inlet valve and the compressed air from the reservoir goes to the brake chambers for applying brakes. Simultaneously air also enters the chamber under piston, through the bleeder hole. So that bottom of the piston is subjected to air pressure and automatically balances the mechanical force applied on the piston by the driver.



**Fig: Brake valve**

The piston is lifted up when the air force is greater than the mechanical force. In this position exhaust valve opens and air escapes through the exhaust port till the differential pressure on two sides of the piston is balanced.

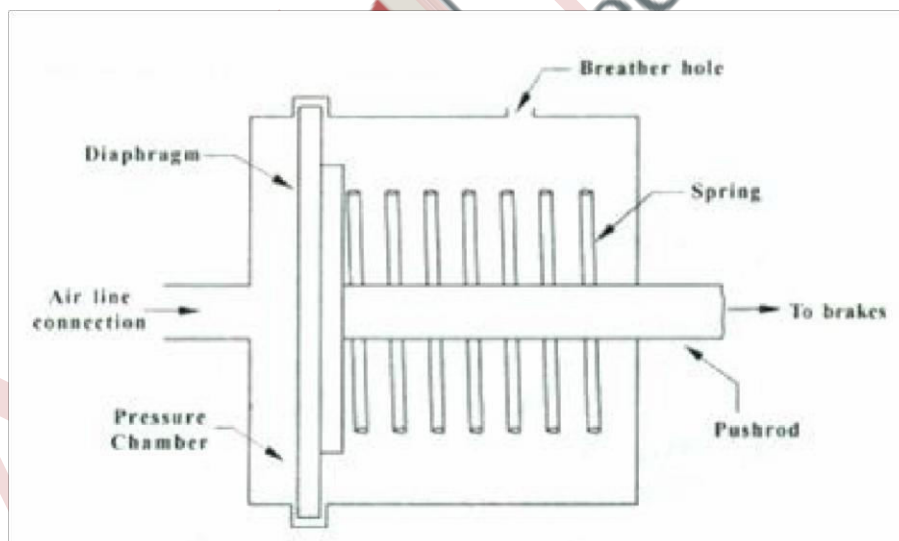
For increasing braking intensity, driver has to apply more mechanical force on the piston through brake pedal. Due to force on the piston, it moves down, thus opening inlet valve more and admitting more air under pressure. The piston reaches a new position of balance.

Whenever the driver wants to decrease the braking intensity, he will release the brake pedal. This causes the piston to move up slightly, thus opens the exhaust valve for air to escape through exhaust port, till a balance of forces is again established on the piston.

If the brake pedal is fully released, there is no mechanical force acting on the piston. The piston moves up due to air pressure underneath of it, thus opens exhaust valve and closes inlet valve. The whole pressure is released through exhaust valve and exhaust port. As the inlet valve is closed, there is no entry of air from the reservoir and hence brakes at the wheels are released.

### Brake Chamber

In brake chamber, pressure energy of compressed air is converted into useful mechanical energy for applying the brakes. Front wheel brake chambers are usually provided with push rods while sliding forks are fitted in rear brakes.



**Fig: Simplified brake chamber of single diaphragm type.**

Figure shows the simplified view of a brake chamber of single diaphragm type. It consists of a diaphragm which is fitted in a chamber as shown. The left side of diaphragm is open to air pressure from brake valve and right side of it is exposed to atmosphere through a breather hole. When brake is applied, the brake valve delivers air at high pressure to the pressure chamber and the differential pressure on both sides of the diaphragm causes it to move towards right, there by operating the push rod which in turn actuates the cam at the wheel to apply brakes.

**UNIT - 8****AUTOMOTIVE EMISSION CONTROL SYSTEMS****INTRODUCTION**

The purpose of emission control is to reduce amount of pollutants and environmentally damaging substances released by the vehicles. If not controlled, the automobile can emit pollutants from fuel tank, carburetor crank case and exhaust system in the atmosphere. The fuel tank and the carburetor emit gasoline vapours, crank case releases partly burned air-fuel mixture blown off by piston rings and pollutants from exhaust system consists of partly burned hydrocarbons, carbon monoxide, nitrogen oxides and sulphur oxide. The smoke may be formed due to incomplete burning of fuel [Smoke: particles of unburned fuel and soot called particulates, mixed with air]. It took many years for the public and the automotive industry to address the problem of these pollutants.

It is estimated that in USA alone 200 million tons of manmade pollutants adds to the air. Therefore-these pollutants, if not controlled, adversely affect our health. Automobile manufacturers have been working towards reduction of auto motive air pollutants when auto emissions were found to be part of the cause of smog. The emission of pollutants can be decreased by improving combustion efficiency which in turn needs redesigning of fuel tank, carburetor combustion chamber, cooling system run on and exhaust system. The other way of controlling atmospheric pollution is, destroy the pollutants after they have been formed.

The emission of pollutants in Auto motives can be reduced by

1. Closed crank case ventilation
2. Fuel tank and carburetor ventilation
3. Redesigning the engine
  - (i) Combustion chamber,
  - (ii) Cooling system,
  - (iii) Fuel supply system and
  - (iv) Ignition system

**CLOSED CRANK CASE VENTILATION [Controlling Crank Case Emissions]:**

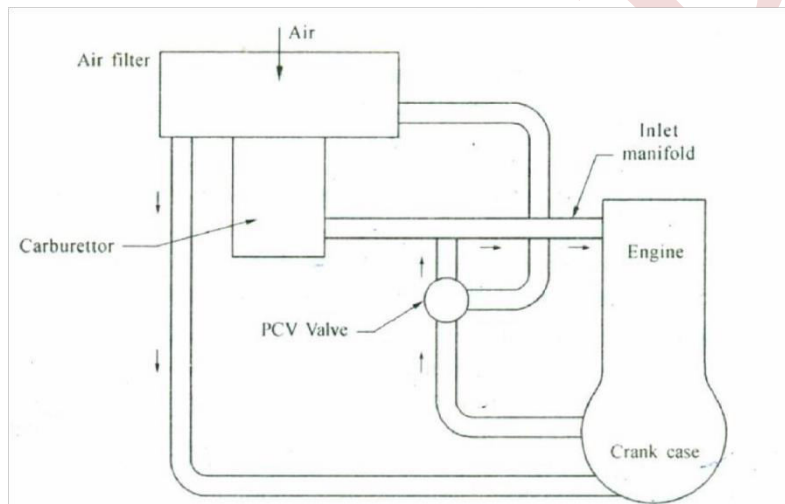
This system consists of two types:

- (i) Positive crank case ventilation and
- (ii) Fixed orifice system.

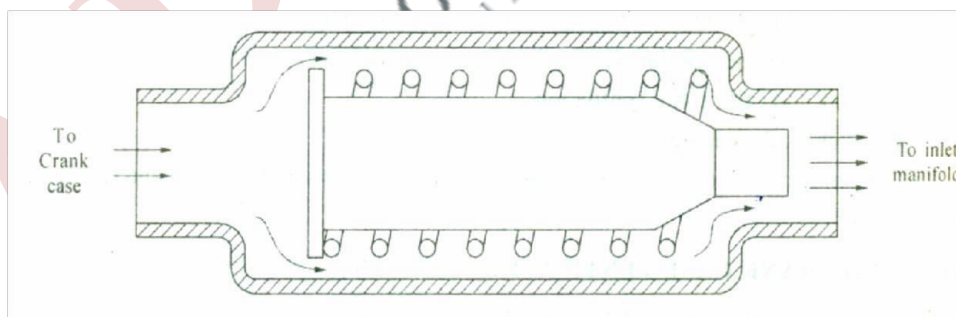
**Positive Crank Case Ventilation Systems [PCV Systems]:**

When engine is running, some unburned fuel and combustion products leak past the piston rings and move into the crank case. This leakage is called blow by. This blow by must be removed

from the engine-Crankcase, before it condenses and reacts with oil to form sludge, which may corrodes and accelerates wear of pistons, piston rings, valves, bearings, etc. Sludge can also clog oil lines and starve the lubricating system. As the engine oil circulates, it also carries blow by and some unburned fuel particles which are formed due to incomplete combustion of air-fuel mixture in to the crank case. If not removed, this dilutes the engine's oil and hence the oil does not lubricate the engine properly resulting in excessive wear. Filtered air from the carburettor air clearer must be circulated through the crank case to remove blow by gases and gasoline vapours from the crank case. To prevent atmospheric pollution modern engines have a closed system called PCV system. The flow by gases and gasoline vapours are picked up by filtered air to the engine inlet manifold through a special PCV valve and from there enters into engine combustion chamber with fresh charge and are burnt there.



**Fig: Schematic diagram of positive crank case ventilation**



**Fig: PCV Valve**

The PCV valve consists of a spring loaded tapered valve. The valve is in closed position under the action of crank case pressure and manifold vacuum where as the spring pressure keeps the valve open there by regulate the flow of blow by gases. During idle or deceleration (low speed) amount of blow by gas is less due to lesser engine load and a small PCV valve opening is needed to move blow by gases out of crank case. The high intake manifold vacuum moves the tapered valve against spring pressure, thus provides small opening in the valve for the flow of blow by gases. During part throttling (or normal speed), engine load is higher than at Idle, blow by increases and manifold vacuum decreases. The spring moves the tapered valve to increase the opening. The larger



opening allows the entire blow by gases to enter in to the intake manifold. At high speeds or when the engine is operating under heavy load, the throttle valve opens widely and decreases intake manifold vacuum. The spring moves the tapered valve further down ward to provide a larger opening through the valve. The amount of blow by gases is more, when engine load is high, hence larger PCV valve opening is essential to allow these gases to flow through the valve in to the intake manifold.

### **Fixed orifice tube PCV System**

Some engines are not fitted with PCV valve. The blow by gases is routed in to the intake manifold through a fixed orifice tube. This system works similar to PCV valve, except that the system is regulated only by the vacuum on the orifice. The amount of blow by gas, flows in to the intake manifold is limited by the size.

### **CONTROLLING EVAPORATIVE EMISSIONS [Evaporative emission control systems]:**

The fuel evaporative control system capture the gasoline vapours from the fuel tank and carburetor float bowl and prevents them from escaping in to the atmosphere. This system is called by various names such as active emission control (EEC), evaporative control systems (ECS), cycle vapour recovery and vapour saver (recovery) system (VVS / NRS): Since fuel injection systems do not have a float bowl, the ECS controls escape of fuel vapours from the fuel tank only.

### **Vapour recovery system in carbureted engines**

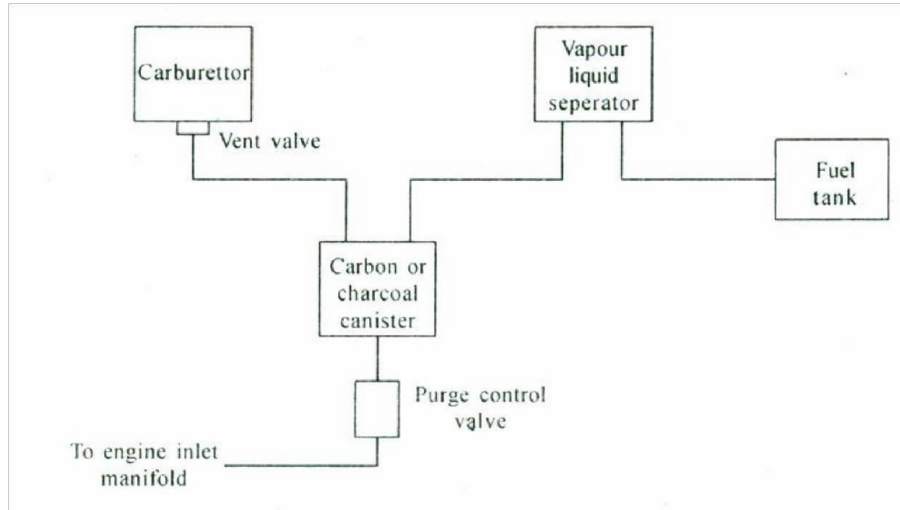
If the vehicle is not fitted with VRS, the gasoline vapours from the fuel tank and carburetor escape in to the atmosphere by evaporation or breathing. The fuel tank breathes with change in temperature. As temperature increases, the air inside the tank expands and thus forced out through either the filter cap vent or the tank vent tube. This air carries gasoline vapour. When the temperature decreases, the air inside contracts and hence outside air enters into the tank. This breathing of tank causes loss of gasoline vapour and discharges it into atmosphere.

The gasoline vapour is also escapes from the carburetor float bowl by evaporation. When the engine is running, the cater float bowl is full. When the engine stops, the heat of the engine evaporates some or all of the gasoline stored in the float bowl.

The vapour recovery system reduces atmospheric pollution by preventing gasoline vapour to escape in to atmosphere. All modern cars are fitted with VRS.

The layout of vapour recovery system is as shown in figure. The fuel tank and carburetor are vented to a carbon or charcoal canister instead of vented in to atmosphere. When the engine stops, fuel vapours run the tank and float bowl enters into a carbon or charcoal canister. In the canister, the activated charcoal adsorbs the vapour and stores it [absorb means - vapours are trapped by sticking to the outside of the charcoal particles]. When the engine starts, the gasoline vapour in the canister is picked up by fresh air flowing through it. Then the air flows into engine intake manifold and becomes part of air fuel mixture entering the engine cylinders. This action of flow of fresh air to pick up the trapped gasoline vapour from the canister is called "Purging". The system also consists of a vapour liquid separator on the fuel tank. This chamber separates vapour from the liquid gasoline which in turn returned to the tank. A mechanically operated vent valve or an electrically operated

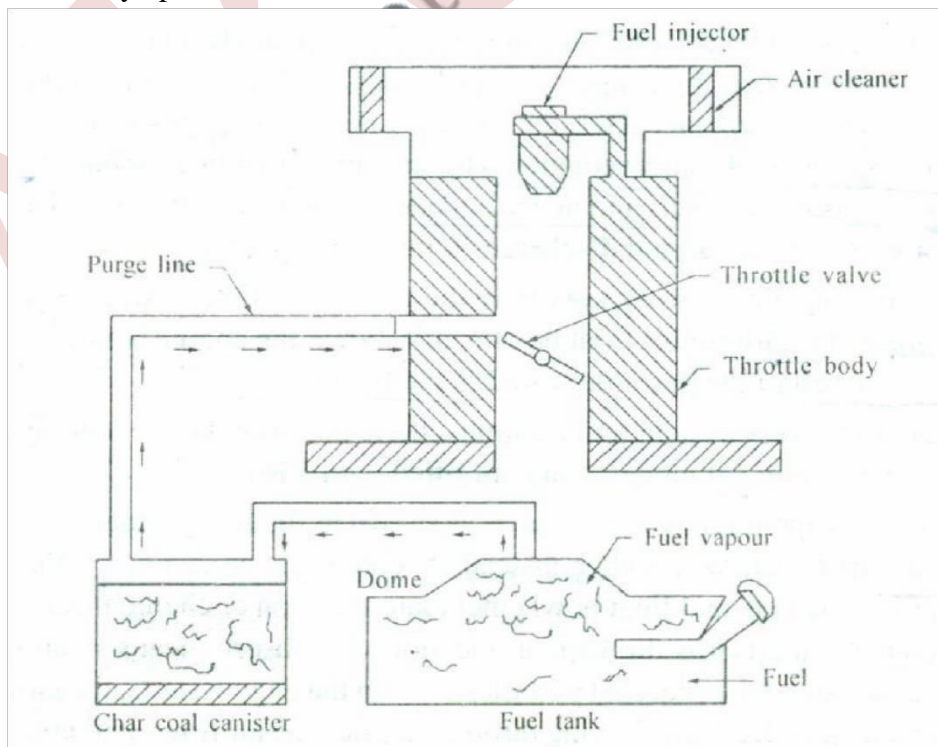
solenoid valve may be used to control flow of vapours from the fuel tank. The mechanical valves operated by the throttle linkage. During idling, it is open and causes the vapour to flow from float chamber to the canister. The opening of throttle closes the vent valve; likewise, the electrical vent valve is open when ignition is off. When the ignition is on, the vent valve is closed by the energisation of solenoid.



**Fig: Schematic diagram of a vapour recovery system**

**Evaporative Control System (ECS) for fuel injected engines**

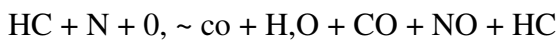
The fuel injection system do not have float bowl, therefore ECS controls escape of fuel vapour from the fuel tank only. The canister is connected to hose from the fuel tank. The purge line from the canister is connected to the throttle body. An electric purge control solenoid may be used instead of vacuum operated purge valve. The solenoid valve may be fitted on the canister or in the purge line and normally open.



**Fig: ECS for an engine with throttle body injection**

## CLEANING THE EXHAUST GAS

The Automotive engines burns liquid fuel gasoline which is a hydrocarbon (HC), made up of hydrogen (H) and carbon (C). During complete combustion, gasoline produces water vapour and carbon dioxide which are harmless to atmosphere. However, in automotive engines, combustion is never completely takes place. Some unburned hydrocarbon (gasoline) and carbon monoxide (formed due to in complete combustion of gasoline) and nitrogen oxide (formed due to high combustion temperature) will remain in the exhaust gas. Therefore combustion can be represented by



The carbon monoxide, HC and NO causes air pollution.

In automotives, sources air pollution are engine crank case, air cleaner or carburetor, fuel tank and tail pipe. The pollutants from each of these sources are controlled by emission control devices like crank case emission control systems, evaporative emission control systems, exhaust emission control system.

The methods used to reduce amount of pollutants in the exhaust gas are

1. Controlling gasoline quality
2. Controlling the air-fuel mixture
3. Controlling the combustion process
4. Treating the exhaust gas

### Controlling gasoline quality

The characteristics of the gasoline can be improved by adding some additives during refining. Good quality gasoline posses following characteristics,

1. **Proper volatility:** This property indicates how easily the gasoline is converted into vapour.
2. **Resistance to detonation or spark knock.**
3. **Oxidation inhibitors:** Avoids gumming tendency in the fuel system.
4. **Anti-rust and Anti-freezers:** To prevent rusting of components in fuel system and avoids blocking of fuels.
5. **Detergents:** To clean carburetor and fuel injector.
6. **Dyes:** gives colour for identification.

### Controlling the air-fuel mixture

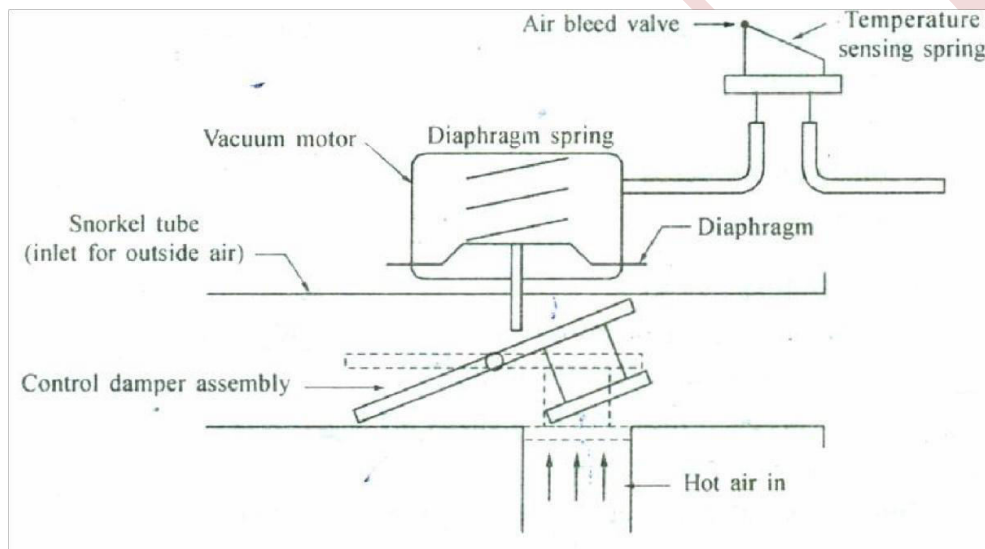
Controlling the air-fuel mixture is nothing but

- i) Modifying the fuel system or carburetor to deliver a leaner air-fuel mixture and
- ii) Faster warm up and quicker choke action.

The ideal air-fuel ratio [14.7: 1] required for complete combustion of fuel is called air-fuel ratio. If this air-fuel ratio is lower, say 14: 1, it means, there is excess fuel for available oxygen. If it is higher, say 16: 1, it means there is an excess of oxygen. As engines operates mostly at part throttle, the ECM maintain air-fuel ratio at stoichiometric ratio during part throttling. The engine performance is better at ideal air-fuel mixture (14.7: 1) and produces minimum exhaust the amount of oxygen in the exhaust gas is indicated oxygen sensor which sends signals to ECM. This shows leanness or richness of air-fuel mixture. Then the ECM adjusts the richness of the mixture.

Faster engine warm up and quicker choke open in reassess exhaust emissions during warm-up. If the carburetor [fuel supply system] supplies cold air-fuel mixture, only a part of fuel will vaporize. This makes the air-fuel mixture lean and extra rich mixture is required. Therefore, when the engine is cold, a thermostatically controlled air cleaner is used to supply heated air quickly to the carburetor. During cold running, air entering carburetor is heated up by thermostatic air cleaner, which allows engine to run on a leaner air-fuel mixture during warm up.

The thermostatic air cleaner consists of a temperature sensing spring which senses temperature of air entering the air cleaner. The air bleeds when air is cold and this applies intake manifold vacuum to the vacuum motor. The diaphragm and hence to control arm per assembly moves up due to atmospheric pressure and thus blocks the snorkel tube. This allows all the air to enter through the hot air pipe which is laid near to the exhaust manifold. When the engine starts, the exhaust manifold heats up quickly, and hence allows heated air to enter into the air cleaner. This heated air helps to vaporize the fuel delivered by carburetor or fuel injectors, which in turn improves cold engine performance



**Fig: Thermostatic air cleaner**

**Controlling Combustion Process**

Combustion in the engine cylinders is a complicated phenomenon. The factors which affect the combustion process are:

- 1) The air-fuel mixture near to the cool cylinder wall, cylinder head, top piston ring and piston head do not burn. The metal surface cools these layers below the combustion point. Therefore, during exhaust stroke, this unburned mixture (fuel) is swept out of the cylinder. This adds polluting HC to the atmosphere. This problem is rectified by introducing stratified charge in the engine cylinder or by fuel injection method. The other method is providing lesser surface area around the combustion chamber. A hemispherical cam has less surface area and releases less unburned HC in to the exhaust.
- 2) The combustion temperature results in better combustion in fuel and reduces unburned HC and CO emissions in the exhaust. But this results in formation of more nitrogen oxide (NO) and adds pollutants to the atmosphere.
- 3) During part throttling, controlled advance provided in the ignition distributor gives the air fuel

mixture a longer time to burn. Under certain operating conditions, this also results in formation of more Nitrogen Oxide. The devices used to prevent vacuum advance are;

**(a) Transmission Controlled Spark TCS or Transmission Regulated Spark (TRS) system:** It delays vacuum advance when the transmission is in neutral reverse and forward gears.

**(b) Spark Delay Valve (SDV):** It prevents vacuum advance during certain conditions of vehicle acceleration.

4) The carbon deposits present in the combustion chamber absorb air-fuel mixture and during exhaust releases air-fuel mixture. The HC in the exhaust gas, add pollutants to the atmosphere.

### Exhaust gas recirculation

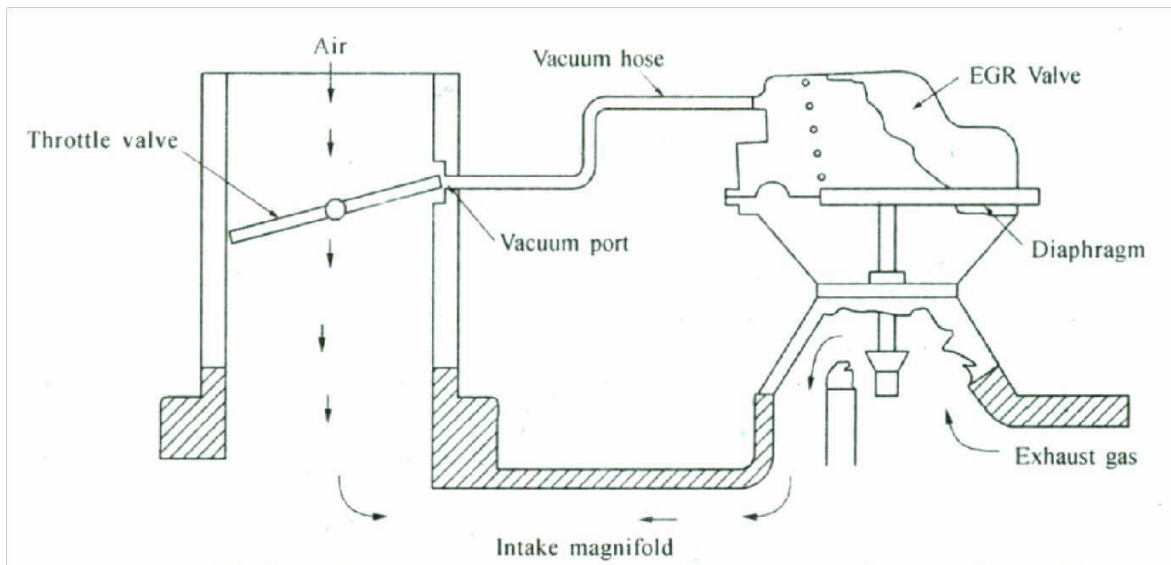
The higher combustion temperature (more than  $1927^{\circ}\text{C}$ ) results in the formation of more Nitrogen Oxides. The exhaust gas recirculation of EGR system is used to lower the combustion temperature and hence to reduce NO emissions in the exhaust gas. A small metered quantity (6 to 13%) of inert exhaust gas is sent back in to the intake manifold to reduce combustion temperature and formation of NO<sub>x</sub> the exhaust gas is relatively at low temperature and absorbs heat from the much hotter combustion process. there by reduces combustion temperature and hence formation of O.

The simplest form of EGR system is as shown in figure. It consists of a passage which connects exhaust manifold and intake manifold. The EGR valve opens and closes the passage and it consists of a spring loaded diaphragm that forms a vacuum chamber at the top of the valve. A tube connects vacuum chamber and vacuum port in the throttle body as shown in figure. In absence of vacuum, the diaphragm moves down due to spring action, thus closes the passage. In this situation, no exhaust gas re-circulates, engine is idle and formation of NO<sub>x</sub> is minimum.

When the throttle opens, it moves past the vacuum port. This allows the intake manifold vacuum to act through the port and moves the diaphragm up to open the valve. As the valve raises up, some exhaust gases passes through the valve in to intake manifold. The exhaust gases mixes with air-fuel mixture and then enters into engine cylinders. This reduces combustion temperature and hence formation of NO<sub>x</sub>.

When the throttle valve is fully opened, a little vacuum exists at the vacuum port and hence EGR valve is nearly closed. However no EGR is needed due to rapid combustion and there is less time for NO<sub>x</sub> formation.

In most of the engines, vacuum is applied to the EGR valve through a ported vacuum switch (PV) or thermal vacuum switch (TVS). It prevents EGR until engine temperature reaches  $38^{\circ}\text{C}$ .



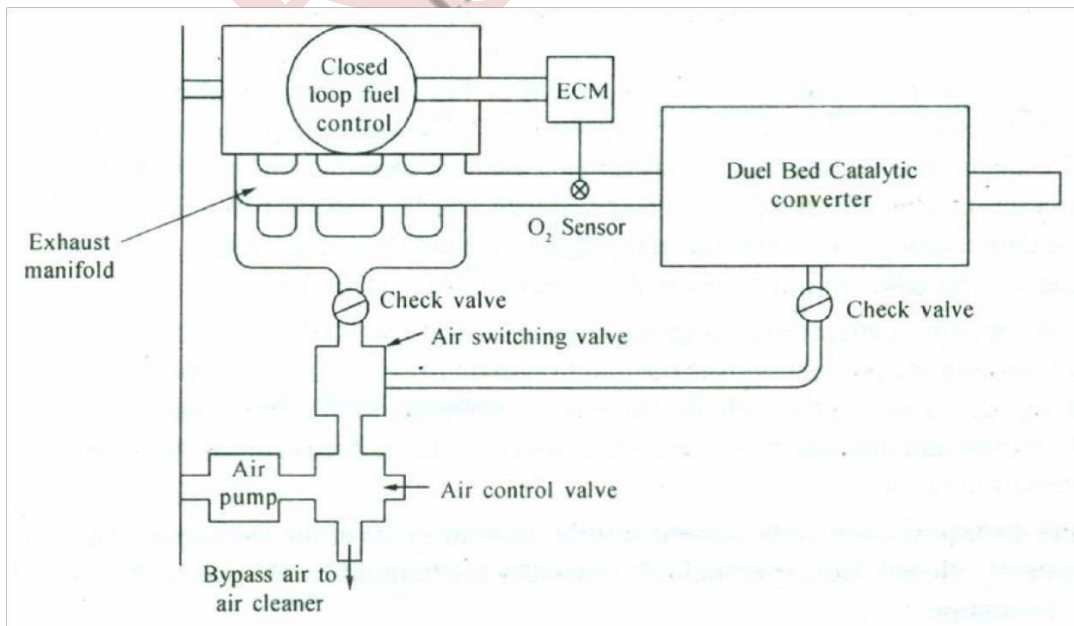
**Fig: Schematic diagram of EGR system**

**TREATING THE EXHAUST GAS**

The exhaust gas is treated before it enters in to atmosphere, to reduce amount of HC, CO and NO. This is done by injecting fresh air into the exhaust system and b passing exhaust gas through a catalytic converter.

**Air injection system**

In this method, the fresh air is blown into the exhaust gases after they exit combustion chamber. This provides additional oxygen to burn HC and CO coming out of cylinders and converts them into water and CO<sub>2</sub>and reduces amount of these pollutants.



**Fig: Air Injection System**

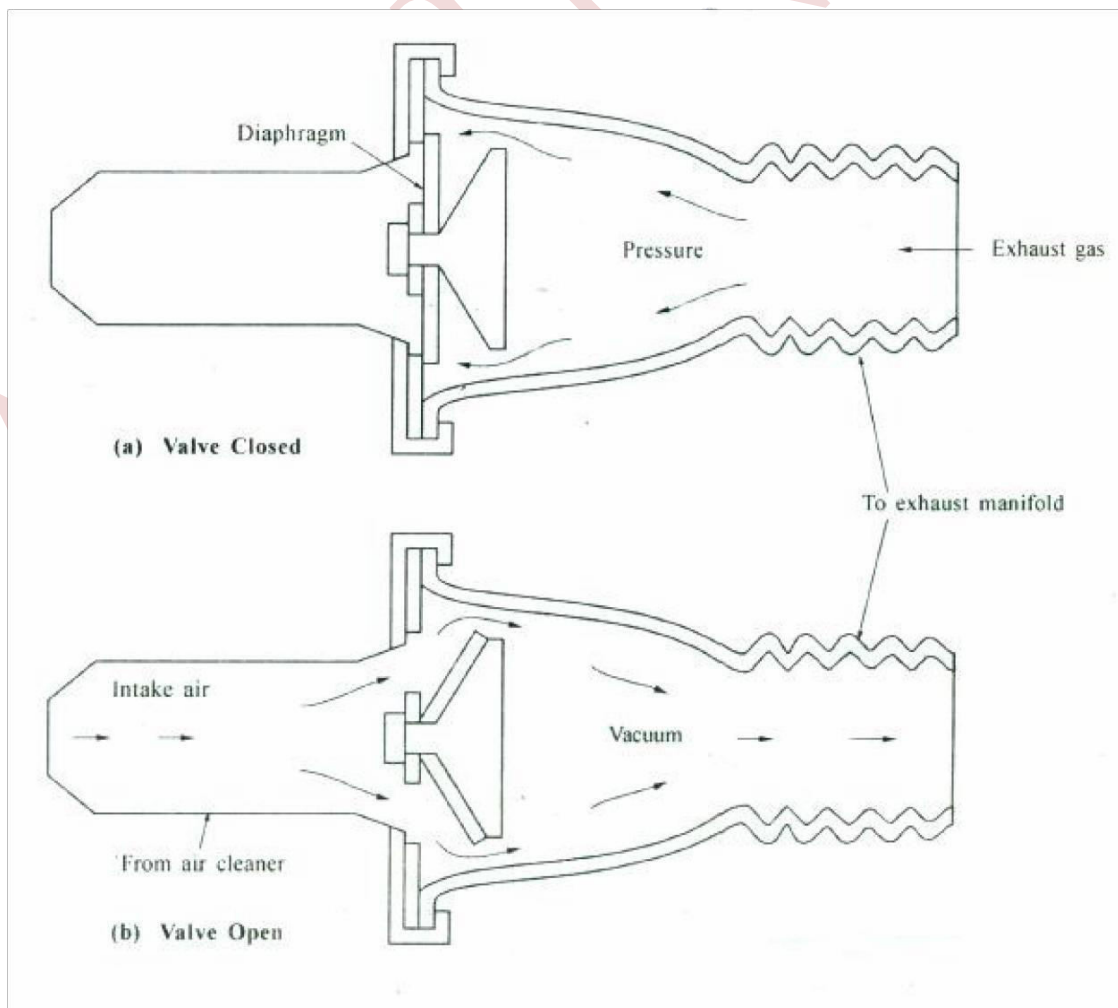
The Air injection system consists of air pump, air switching and control valves and the one way check valves. When the engine is cold, the air pump pushes air through nozzles to the exhaust manifold. The nozzles are located opposite to exhaust ports and hence O<sub>2</sub> in the air helps to burn any HC and CO in the exhaust gas in the exhaust manifold.

When the engine warms up, ECM causes the air to pass through catalytic converter, where HC and CO are converted into H<sub>2</sub> and CO. The check valve avoids back flow of exhaust gases to the air pump in case of back fire. During deceleration, the bypass valve momentarily diverts air from air pump to the air cleaner, instead of to the exhaust manifold. This avoids back firing in the exhaust system.

**Air aspirator System**

Some Engines uses air aspirator valve in place of air pump. This is a one way check valve. The opening and closing of exhaust valve causes variation in the exhaust manifold pressure. When this exhaust pressure is below atmospheric, fresh air admits through air aspirator valve to the nozzles in the exhaust manifold.

The air aspirator valve closes when exhaust valve opens which causes pressure in the exhaust manifold to increase above atmospheric.



**Fig: Air aspirator valve**

## CATALYTIC CONVERTER

The function of catalytic converter is to treat the exhaust gas to convert harmful pollutants into harmless. All exhaust gases must pass through catalytic converter which is located in exhaust system. The catalytic converter consists of a material called catalyst which causes a chemical change without entering into chemical reaction. It makes two chemicals to react with each other and hence reduces amount of HC, CO and NO<sub>x</sub> in the exhaust gases.

It consists of two different catalysts, one to treat HC and CO and other to treat NO<sub>x</sub>. The first catalyst promotes HC to unite with O<sub>2</sub> to produce H<sub>2</sub>O and CO<sub>2</sub>, The second catalyst promotes CO to react with O<sub>2</sub> and hence to release CO<sub>2</sub>. As this converter oxidises HC and CO, it is known as oxidising converter. The platinum and palladium are listed as oxidising catalysts.

The catalyst used for NO, splits O<sub>2</sub> and N<sub>2</sub> and hence NO<sub>x</sub> becomes harmless N<sub>2</sub> and O<sub>2</sub>, the converter is known as reducing converter and metal rhodium is used for this purpose. A large surface area of catalytic converter is coated with catalyst. The coated surface area or substrate is in the form of a bed of small beads or pellets or a ceramic honey comb. Usually honeycomb converter is round and pellet type converter is flat.

The vehicles fitted with catalytic converter in the exhaust system must use unleaded gasoline otherwise lead in the gasoline coats the catalyst and makes the converter ineffective. The air fuel ratio for the mixture must be stoichiometric ratio for effective working of the catalytic converter.

### Dual Bed and Three way catalytic converters

A dual bed catalytic converter consists of two pellet beds, one over the other and are separated by an air chamber. The pellets coated with three way catalyst reduce NO, into N<sub>2</sub> and O<sub>2</sub> is provided on the upper bed. It also helps to oxidise HC and CO. The lower bed acts as two way catalyst and oxidises remaining HC and CO. When the vehicle warms up, the air pump supplies secondary air to the air chamber to separate the upper and lower beds.

## EMISSION STANDARDS

As vehicle populations grow and cities become more congested the allowable emissions from engines have been lowered to maintain air quality in major cities. The pollutants from vehicles cause several health problems, leads to formation of smog and affects environment. Many countries are aiming at achieving safe concentrations of these pollutants by regulating their level of emissions. Emission standards are requirements that set specific limits to the amount of pollutants that can be released into the environment. These emission standards regulate pollutants released by automobiles, industry, power plants and diesel generators etc. Generally these standards regulate the emissions of nitrogen oxides, sulphur oxides, particulate matter (PM) or soot, carbon monoxide and volatile hydrocarbons. These emission standards put limits for conventional pollutants and regulate green house gases particularly carbon dioxide. In USA, emission standards are managed by the Environmental Protection Agency. In the state of California, California's emission standards are set to influence emission requirements that major automakers must meet. The European Union has set its own emission standards for all road vehicles, trains, barges etc. No standards apply to seagoing ships or aero planes. The European Union has introduced Euro 4 from 1-1-2008, introducing Euro 5



from 1-1-2010 and Euro 6 from 1-1-2014. Many of the other countries also confirm to the euro 4 standards from Jan 2009. In 198~ India introduced first Indian emission regulations to limit idle emissions. From 2000 India started adopting European emission and fuel regulations for four wheeled light duty and for heavy duty vehicles. Indian owned emission regulations still apply to two and three wheeled vehicles. All transport vehicles must have a fitness certificate that is renewed each year after the first five years of new vehicle registration.

On October 6, 2003, the National Auto Fuel Policy has been announced which envisages a phase I-program for introducing Euro 2-4 emission and fuel regulations by 2010.

The table shows the implementation schedule of EU emission standards in India.

Standard	Reference	Date	Region
India 2000	Euro 1	2000	Nation wide
Bharat Stage II	Euro2	2001	Delhi, Mumbai, Kolkata, Chennai
Bharat Stage III	Eur03	2005	Delhi, Mumbai, Kolkata, Chennai, Hyderabad, Ahmedabad, Pune, Kanpur and Agra
		2010	Nation wide
Bharat Stage IV	Eur04	2010	Delhi, Mumbai, Kolkata, Chennai, Hyderabad, Ahmedabad, Pune, Kanpur and Agra

For Two and Three wheelers, Bharat Stage II (Euro 2) was recommended from April 1, 2005 and Bharat Stage III (Euro 3) was applied from April 1, 2008.

Emission Standards for Diesel Truck and Bus Engines, g/kWh

Year	Reference	CO	HC	NO	PM
1992	--	17.3 - 32.6	2.7 - 3.7	x -	--
1996	--	11.20	2.40	14.4	--
2000	Euro I	4.5	1.1	8.0	0.36
2005	Euro II	4.0	1.1	7.0	0.15
2010	Euro III	2.1	0.66	5.0	0.10

Emission Standards for Light-Duty Diesel Vehicles, g/km

Year	Reference	CO	HC	HC+NO	PM
1992	-	17.3 - 32.6	2.7 - 3.7	x	-
1996	-	5.0 - 9.0	-	2.0 - 4.0	~
2000	Euro I	2.72 - 6.90	-	0.97 - 1.70	0.14 - 0.25
2005	Euro2	1.0 - 1.5	-	0.7 - 1.2	0.08 - 0.17

Emission Standards for Light-Duty Diesel Engines, g/kWh

Year	Reference	CO	HC	NO	PM
1992	-	14.0	3.5	• 18.0	-
1996	-	11.20	2.40	14.4	-
2000	Euro I	4.5	1.1	8.0	0.36*
2005	Euro II	4.0	1.1	7.0	0.15

Emission Standards for Gasoline Vehicles (GVW s 3,500 kg), g/km

Year	Reference	CO	HC	HC+NO
1991	-	14.3-27.1	2.0 - 2.9	, -
1996	-	8.68 - 12.4	-	3.00 - 4.36
1998*	-	4.34 - 6.20	-	• 1.50 - 2.18
2000	Euro I	2.72 - 6.90	-	0.97 - 1.70
2005	Euro II	2.2 - 5.0	-	0.5 - 0.7

\* For catalytic converter fitted vehicles

Emission Standards for 3-Wheel Gasoline Vehicles, g/km

Year	CO	HC	HC+NO
1991	12 - 30	8 - 12	x
1996	6.75	-	5.40
2000	4.00	-	2.00
2005 (BSII)	2.25	-	2.00

Catalytic converters have been instrumental in reducing emissions of harmful gases from vehicles since their inception in response to the US Clean Air Act of 1970. Regulated emissions have been reduced approximately 1/3 while the number of cars on the road have more than doubled. Platinum, palladium and rhodium are essential components in automobile catalytic converters reducing engine-out emissions by well over 90%, and in some cases by over 99%.

**Overview of the emission norms in India**

- 1) 1991 - Idle 'CO' Limits for Gasoline Vehicles and Free Acceleration Smoke for Diesel Vehicles, Mass Emission Norms for Gasoline Vehicles.
- 2) 1992 - Mass Emission Norms for Diesel Vehicles.
- 3) 1996 - Revision of Mass Emission Norms for Gasoline and Diesel Vehicles, mandatory fitment of Catalytic Converter for Cars in Metros on Unleaded Gasoline.
- 4) 1998 - Cold Start Norms Introduced.
- 5) 2000 - India 2000 (Eq. to Euro I) Norms, Modified IDC (Indian Driving Cycle), Bharat Stage II Norms for Delhi.
- 6) 2001 - Bharat Stage II (Eq. to Euro II) Norms for all Metros, Emission Norms for CNG & LPG Vehicles.
- 7) 2003 - Bharat Stage II (Eq. to Euro II) Norms for 11 major cities.
- 8) 2005 - From 1<sup>st</sup> April Bharat Stage III (Eq. to Euro III) Norms for 11 major cities.
- 9) 2010 - Bharat Stage III Emission Norms for 4-wheelers for entire country whereas Bharat Stage - IV (Eq. to Euro IV) for 11 major cities. Bharat Stage IV also has norms on OBD (similar to Euro III but diluted).